



SERVICE MANUAL

SANYO

FILE NO.

Revised edition

ECO MULTI
ECONOMY & ECOLOGY

NEW OZONE ERA, KEEP THE GREEN WORLD
R407C

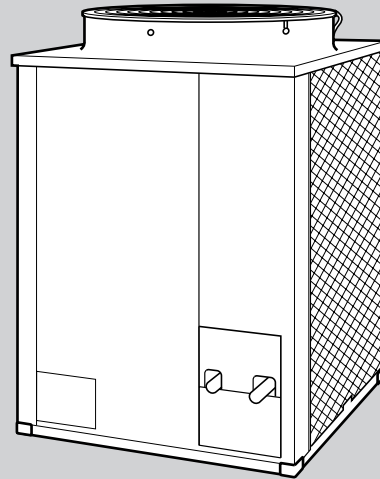
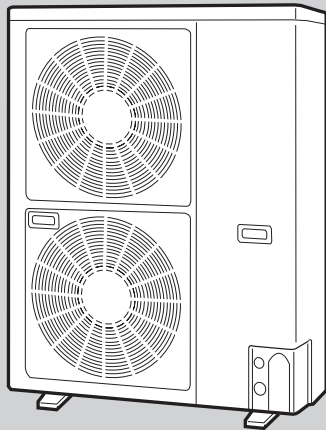

1

2

3

4

OUTDOOR MODEL No.	PRODUCT CODE No.	APPLICABLE INDOOR MODEL No.		V / ϕ / Hz
SPW-CR363GVH8	85401464	SPW - KR · ASR · SR · UR · FR · FMR · SLR	93GH56	OUTDOOR 380 - 415 / 3 ϕ / 50
SPW-CR483GVH8	85401465	SPW - XR · KR · ASR · SR · UR · FR · FMR · SLR	123GH56	
SPW-CR703GVH8	85401468	SPW - XR · KR · TR · SR · UR · FR · FMR · SLR	183GH56	
SPW-CR903GVH8	85401469	SPW - XR · TR · SR · UR · DR · FR · FMR · SLR	253GH56	INDOOR 220 - 240 / 1 ϕ / 50
SPW-CR363GV8	85401466	SPW - XR · TR · UR · DR	363GH56	
SPW-CR483GV8	85401467	SPW - XR · TR · UR · DR	483GH56	
SPW-CR703GV8	85401470			
SPW-CR903GV8	85401471			

Important

Please Read Before Starting

This air conditioning system meets strict safety and operating standards. As the installer or service person, it is an important part of your job to install or service the system so it operates safely and efficiently.

For safe installation and trouble-free operation, you must :

- Carefully read this instruction booklet before beginning.
- Follow each installation or repair step exactly as shown.
- Observe all local, state, and national electrical codes.
- Pay close attention to all warning and caution notices given in this manual.



WARNING

This symbol refers to a hazard or unsafe practice which can result in severe personal injury or death.



CAUTION

This symbol refers to a hazard or unsafe practice which can result in personal injury or product or property damage.

If Necessary, Get Help

These instructions are all you need for most installation sites and maintenance conditions. If you require help for a special problem, contact our sales/service outlet or your certified dealer for additional instructions.

In Case of Improper Installation

The manufacturer shall in no way be responsible for improper installation or maintenance service, including failure to follow the instructions in this document.

SPECIAL PRECAUTIONS

When Wiring



ELECTRICAL SHOCK CAN CAUSE SEVERE PERSONAL INJURY OR DEATH. ONLY A QUALIFIED, EXPERIENCED ELECTRICIAN SHOULD ATTEMPT TO WIRE THIS SYSTEM.

- Do not supply power to the unit until all wiring and tubing are completed or reconnected and checked.
- Highly dangerous electrical voltages are used in this system. Carefully refer to the wiring diagram and these instructions when wiring. Improper connections and inadequate grounding can cause **accidental injury or death**.
- **Ground the unit** following local electrical codes.
- Connect all wiring tightly. Loose wiring may cause overheating at connection points and a possible fire hazard.

When Transporting

Be careful when picking up and moving the indoor and outdoor units. Get a partner to help, and bend your knees when lifting to reduce strain on your back. Sharp edges or thin aluminum fins on the air conditioner can cut your fingers.

When Installing

...In a Room

Properly insulate any tubing run inside a room to prevent "sweating" that can cause dripping and water damage to walls and floors.

...In Moist or Uneven Locations

Use a raised concrete pad or concrete blocks to provide a solid, level foundation for the outdoor unit. This prevents water damage and abnormal vibration.

...In an area with High Winds

Securely anchor the outdoor unit down with bolts and a metal frame. Provide a suitable air baffle.

...In a Snowy Area (for Heat Pump-type Systems)

Install the outdoor unit on a raised platform that is higher than drifting snow. Provide snow vents.

When Connecting Refrigerant Tubing

- Ventilate the room well, in the event that refrigerant gas leaks during the installation. Be careful not to allow contact of the refrigerant gas with a flame as this will cause the generation of poisonous gas.
- Keep all tubing runs as short as possible.
- Use the flare method for connecting tubing.
- Apply refrigerant lubricant to the matching surfaces of the flare and union tubes before connecting them, then tighten the nut with a torque wrench for a leak-free connection.
- Check carefully for leaks before starting the test run.

NOTE

Depending on the system type, liquid and gas lines may be either narrow or wide. Therefore, to avoid confusion the refrigerant tubing for your particular model is specified as either "narrow" or "wide" rather than as "liquid" or "gas".

When Servicing

- Turn the power OFF at the main power box (mains) before opening the unit to check or repair electrical parts and wiring.
- Keep your fingers and clothing away from any moving parts.
- Clean up the site when installation is finished. Check that no metal scraps or bits of wiring have been left inside the unit.



CAUTION

- Ventilate any enclosed areas when installing or testing the refrigeration system. Contact of refrigerant gas with fire or heat can produce poisonous gas.
- Confirm after installation that no refrigerant gas is leaking. If the gas comes in contact with a burning stove, gas water heater, electric room heater or other heat source, it can cause the generation of poisonous gas.

Check of Density Limit

Important

The room in which the air conditioner is to be installed requires a design that in the event of refrigerant gas leaking out, its density will not exceed a set limit.

The refrigerant R-407C which is used in the air conditioner is safe, without the toxicity or combustibility of ammonia, and is not restricted by laws to be imposed which protect the ozone layer. However, since it contains more than air, it poses the risk of suffocation if its density should rise excessively. Suffocation from leakage of R-407C is almost non-existent. With the recent increase in the number of high density buildings, however, the installation of multi air conditioner systems is on the increase because of the need for effective use of floor space, individual control, energy conservation by curtailing heat and carrying power etc.

Most importantly, the multi air conditioner system is able to replenish a large amount of refrigerant compared with conventional individual air conditioners. If a single unit of the multi air conditioner system is to be installed in a small room, select a suitable model and installation procedure so that if the refrigerant accidentally leaks out, its density does not reach the limit (and in the event of an emergency, measures can be made before injury can occur).

In a room where the density may exceed the limit, create an opening with adjacent rooms, or install mechanical ventilation combined with a gas leak detection device. The density is as given below.

Total amount of refrigerant (kg)

Min. volume of the indoor unit installed room (m^3)
 \leq Density limit (kg/m^3)

The density limit of R-407C which is used in multi air conditioners is $0.3 kg/m^3$.

NOTE 1 : If there are 2 or more refrigerating systems in a single refrigerating device, the amount of refrigerant should be as charged in each independent device.

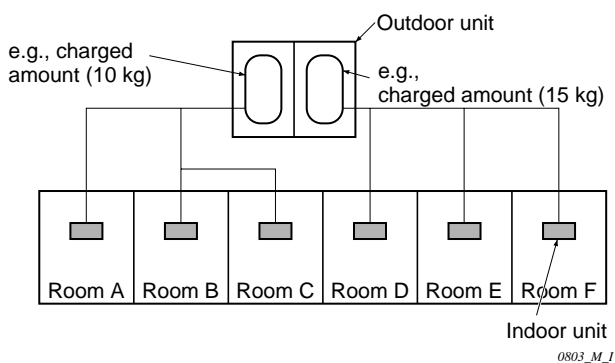

For the amount of charge in this example:

The possible amount of leaked refrigerant gas in rooms A, B and C is 10 kg.

The possible amount of leaked refrigerant gas in rooms D, E and F is 15 kg.

NOTE 2 : The standards for minimum room volume are as follows.

(1) No partition (shaded portion)

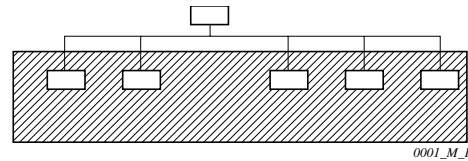

(2) When there is an effective opening with the adjacent room for ventilation of leaking refrigerant gas (opening without a door, or an opening 0.15% or larger than the respective floor spaces at the top or bottom of the door).

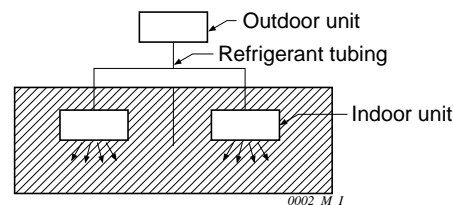

(3) If an indoor unit is installed in each partitioned room and the refrigerant tubing is interconnected, the smallest room of course becomes the object. But when a mechanical ventilation is installed interlocked with a gas leakage detector in the smallest room where the density limit is exceeded, the volume of the next smallest room becomes the object.

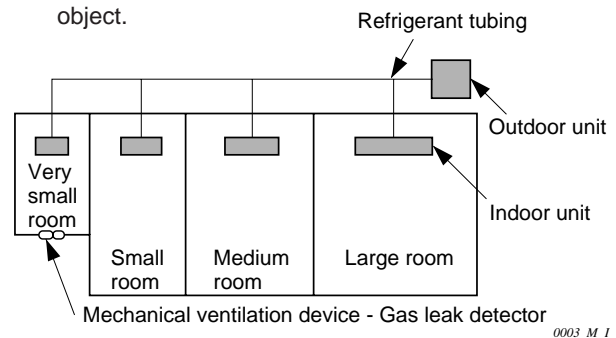

NOTE 3 : The minimum indoor floor space compared with the amount of refrigerant is roughly as follows. (When the ceiling is 2.7 m high)

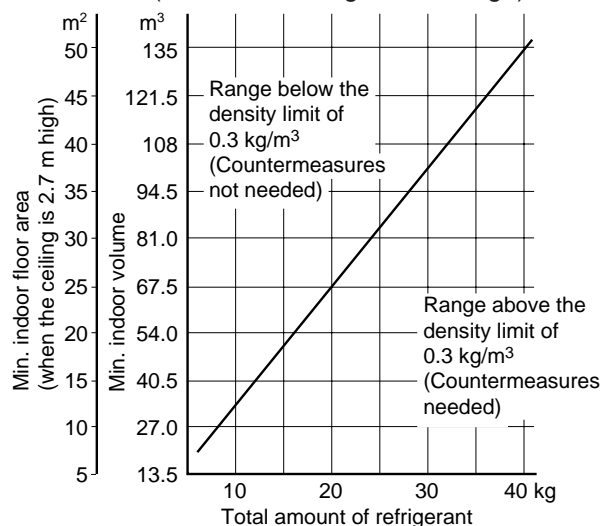















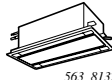
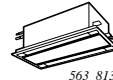
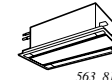
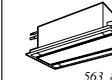
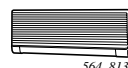
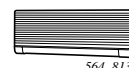
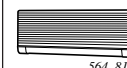

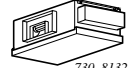
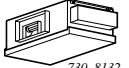

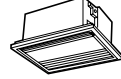
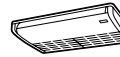

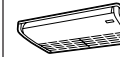
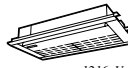
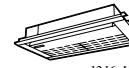
— Contents —

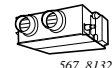
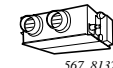
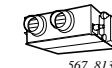
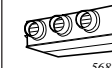
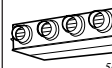
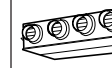
Page

Please Read Before Starting Important	i
Check of Limit Density Important	ii
Line Up	iv
Section 1 : ECO MULTI SYSTEM Unit Specifications	I - 1
1. Outdoor Unit	I - 3
2. 4-way Air Discharge Semi-concealed Type	I - 19
3. 2-way Air Discharge Semi-concealed Type	I - 34
4. 1-way Air Discharge Semi-concealed Type	I - 48
5. Wall Mounted Type	I - 56
6. Ceiling Mounted Type	I - 66
7. Concealed Duct Type	I - 78
8. Concealed Duct High Static Pressure Type	I - 97
9. Floor-Standing Type (F Type)	I - 107
10. Concealed Floor-Standing Type (FM Type)	I - 119
11. 1-way Air Discharge Semi-concealed-Slim Type (SL Type)	I - 135
Section 2 : Processes and Functions	II - 1
1. Compressor Control	II - 2
2. Reverse Cycle Defrosting	II - 6
3. Reverse Cycle Starting Control	II - 7
4. Outdoor Fan Control	II - 7
5. 4-way Valve Switching Control	II - 7
6. Save Valve Control	II - 7
7. Outdoor Electronic Control Valve	II - 8
8. Liquid Valve Control	II - 8
9. Room Temperature Control	II - 9
10. Auto. Mode for Automatic Heating/Cooling Switching	II - 10
11. Heating Preparations	II - 11
12. Dehumidifying Control	II - 12
13. Automatic Fan Speed Control	II - 12
14. Auto-flap Control	II - 13
15. Drain Pump Control	II - 14
16. Indoor Electronic Control Valve	II - 14
17. Discharge Temperature Control (Only for U, D Type)	II - 15
18. Automatic Restart Function after Power Failure	II - 15
19. Filter Sign	II - 15
Section 3 : Service Procedures	III - 1
1. Troubleshooting	III - 2
2. Sensor and Solenoid Layout Diagram	III - 37
3. Thermistor Characteristic Curve	III - 46
4. Test Run	III - 47
5. PCBs illustrations	III - 50
6. Check of Density Limit	III - 53
7. Cautions for New Refrigerant R407C	III - 54
8. Compressor Failure	III - 56
9. Operation Procedure for Replacing the Compressor	III - 57
10. Malfunction due to Noise	III - 59
11. Checking procedure for PCB (Printed Circuit Board)	III - 59
12. Check Pins	III - 60
13. Double Speed of Time for the Timer	III - 60
Section 4 : Electrical Data	IV - 1
1. Outdoor Unit	IV - 2
2. Indoor Unit	IV - 10

Line Up



Indoor Units

Type	9	12	18	25	36	48
Capacity: kW (BTU/h) Cooling / Heating	2.8 (9,600) / 3.2 (11,000)	3.6 (12,000) / 4.2 (14,000)	5.6 (19,000) / 6.3 (21,000)	7.3 (25,000) / 8.0 (27,000)	10.6 (36,000) / 11.4 (39,000)	14.0 (47,800) / 16.0 (54,600)
4-Way Air Discharge Semi-Concealed Type		 566_8132 XR123GH	 566_8132 XR183GH	 566_8132 XR253GH	 729_8132 XR363GH	 729_8132 XR483GH
2-Way Air Discharge Semi-Concealed Type	 563_8132 SR93GH	 563_8132 SR123GH	 563_8132 SR183GH	 563_8132 SR253GH		
Wall-Mounted Type & Concealed-Duct High Static Pressure Type	 564_8132 KR93GH	 564_8132 KR123GH	 564_8132 *KR183GH	 730_8132 DR253GH	 730_8132 DR363GH	 730_8132 DR483GH
1-Way Air Discharge Semi-Concealed Type & Ceiling-Mounted Type	 584_8132 ASR93GH	 584_8132 ASR123GH	 1215_V_I TR183GH	 1215_V_I TR253GH	 1215_V_I TR363GH	 1215_V_I TR483GH
1-Way Air Discharge Semi-Concealed- Slim Type (SL type)	 1216_V_I SLR93GH56	 1216_V_I SLR123GH56	 1216_V_I SLR183GH56	 1216_V_I SLR253GH56		
Concealed-Duct Type	 567_8132 UR93GH	 567_8132 UR123GH	 567_8132 UR183GH	 568_8132 UR253GH	 569_8132 UR363GH	 569_8132 UR483GH
Floor Standing Type (F type)	 0855_V_I FR93GH	 0855_V_I FR123GH	 0856_V_I FR183GH	 0856_V_I **FR253GH		
Concealed Floor Standing Type (FM type)	 0857_V_I FMR93GH	 0857_V_I FMR123GH	 0858_V_I FMR183GH	 0858_V_I **FMR253GH		

* KR183GH: Cooling / Heating capacity is 5.0 (17,000) / 6.0 (20,000) : KW (BTU / h)

** FR253GH, FMR253GH: Cooling / Heating capacity is 7.1 (24,000) / 8.0 (27,000) : KW (BTU / h)

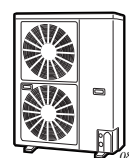
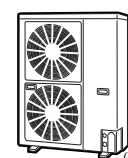
Outdoor units

Type	36	48	70	90
Capacity: kW (BTU/h) Cooling / Heating	11.2 (38,200) / 12.5 (42,700)	14 (47,800) / 16 (54,600)	22.4 (76,400) / 25.0 (85,300)	28.0 (95,500) / 31.5 (107,500)
Outdoor Unit Heat pump Cooling Only	 0859_C_S CR363GVH8 CR363GV8	 0859_C_S CR483GVH8 CR483GV8	 570_8132 CR703GVH8 CR703GV8	 570_8132 CR903GVH8 CR903GV8
Indoor / Outdoor Unit Capacity Ratio $\frac{\text{Indoor Unit Total Capacity}}{\text{Outdoor Unit Capacity}} \times 100$	Max. 130 % (Cooling)			
Operating Range Outdoor Air Intake Temperature	Cooling -5 °C ~ 43 °C DB / Heating -15 °C ~ 15.5 °C WB			
Limit of Elevation Difference	40 m (When outdoor unit installed higher)		50 m (When outdoor unit installed higher)	
	30 m (When outdoor unit installed lower)		30 m (When outdoor unit installed lower)	
Limit of Tubing Length	70 m		100 m	
Allowable No. of Indoor Unit Connected	5 units	6 units	10 units	13 units

Contents

1. ECO MULTI SYSTEM Unit Specifications

1. Outdoor Unit	I - 3
1-1. Specifications	I - 3
1-2. Major component specifications	I - 9
1-3. Control specifications	I - 12
1-4. Other component specifications	I - 13
1-5. Dimensional data	I - 15
1-6. Refrigerant flow diagram	I - 16
1-7. Noise criterion curves	I - 18
2. 4-way Air Discharge Semi-concealed Type (X Type)	I - 19
2-1. Specifications	I - 19
2-2. Major component specifications	I - 24
2-3. Other component specifications	I - 29
2-4. Dimensional data	I - 30
2-5. Noise criterion curves	I - 32
2-6. Air throw distance chart	I - 33
3. 2-way Air Discharge Semi-concealed Type (S Type)	I - 34
3-1. Specifications	I - 34
3-2. Major component specifications	I - 38
3-3. Other component specifications	I - 42
3-4. Dimensional data	I - 43
3-5. Noise criterion curves	I - 45
3-6. Air throw distance chart	I - 47
4. 1-way Air Discharge Semi-concealed Type (AS Type)	I - 48
4-1. Specifications	I - 48
4-2. Major component specifications	I - 50
4-3. Other component specifications	I - 52
4-4. Dimensional data	I - 53
4-5. Noise criterion curves	I - 54
4-6. Air throw distance chart	I - 55
5. Wall-Mounted Type (K Type)	I - 56
5-1. Specifications	I - 56
5-2. Major component specifications	I - 59
5-3. Other component specifications	I - 62
5-4. Dimensional data	I - 63
5-5. Noise criterion curves	I - 64
5-6. Air throw distance chart	I - 65
6. Ceiling-Mounted Type (T Type)	I - 66
6-1. Specifications	I - 66
6-2. Major component specifications	I - 70
6-3. Other component specifications	I - 74
6-4. Dimensional data	I - 75
6-5. Noise criterion curves	I - 76
6-6. Air throw distance chart	I - 77
7. Concealed-Duct Type (U Type)	I - 78
7-1. Specifications	I - 78
7-2. Major component specifications	I - 84
7-3. Other component specifications	I - 90
7-4. Dimensional data	I - 91
7-5. Noise criterion curves	I - 94
7-6. Increasing the fan speed	I - 96
8. Concealed-Duct High Static Pressure Type (D Type)	I - 97
8-1. Specifications	I - 97
8-2. Major component specifications	I - 100
8-3. Other component specifications	I - 103
8-4. Dimensional data	I - 104
8-5. Noise criterion curves	I - 105
8-6. Indoor fan performance	I - 106

Contents

9. Floor Standing Type (F Type)	I - 107
9-1. Specifications	I - 107
9-2. Major component specifications	I - 111
9-3. Other component specifications	I - 115
9-4. Dimensional data	I - 116
9-5. Noise criterion curves	I - 117
9-6. Air throw distance chart	I - 118
10. Concealed Floor Standing Type (FM Type)	I - 119
10-1. Specifications	I - 119
10-2. Major component specifications	I - 123
10-3. Other component specifications	I - 127
10-4. Dimensional data	I - 128
10-5. Noise criterion curves	I - 129
10-6. Air throw distance chart	I - 130
10-7. Indoor fan performance	I - 131
11. 1-way Air Discharge Semi-concealed-Slim Type (SL Type)	I - 135
11-1. Specifications	I - 135
11-2. Major component specifications	I - 139
11-3. Other component specifications	I - 143
11-4. Dimensional data	I - 144
11-5. Noise criterion curves	I - 145
11-6. Air throw distance chart	I - 146

1

1. Outdoor Unit

1-1. Specifications

Unit specifications (A)

MODEL No.	Outdoor Unit		SPW – CR363GVH8					
POWER SOURCE			380 - 400 - 415 V / 3 N / 50Hz					
PERFORMANCE			Cooling			Heating		
Capacity		kW BTU / h	11.2 38,200			12.5 42,700		
Air circulation (Hi)	m ³ /min(cu. ft/min)		84 (2,970)					
ELECTRICAL RATINGS								
Voltage rating		V	380	400	415	380	400	415
Available voltage range		V	342 - 456					
Running amperes		A	7.9	7.9	7.9	8.0	7.7	8.0
Max. running amperes*		A	9.0	8.9	8.7	–	–	–
Power input		kW	4.62	4.60	4.64	4.69	4.52	4.68
Max. power input*		kW	5.22	5.18	5.13	–	–	–
Power factor		%	89	84	82	89	85	81
C.O.P		W/W	2.42	2.43	2.41	2.67	2.77	2.67
Compressor locked rotor amperes		A	51	53	55	51	53	55
FEATURES								
Controls			Microprocessor					
Defrost control			Reverse cycle, microprocessor control					
Service function			Sensor temp. recall function Past service warnings recall function					
Refrigerant amount at shipment		kg	R407C - 3.4					
Refrigerant control			Electronic expansion valve					
Operation sound (Hi)		dB-A	55					
External finish			Galvanized steel plate with powder paint					
Color (Approximate value)			Munsell 5Y8.4 / 0.5, RAL 9002-GL					
REFRIGERANT TUBING								
Limit of tubing length		m(ft.)	70 (230)					
Limit of elevation difference between the two units		m(ft.)	Outdoor unit is higher than indoor unit : 40 (131) Outdoor unit is lower than indoor unit : 30 (98)					
Refrigerant tube outer diameter	Narrow tube	mm (in)	9.52 (3 / 8)					
	Wide tube	mm (in)	19.05 (3 / 4)					
Refrigerant tubing kit / joint kit			Optional					
DIMENSIONS & WEIGHT			Unit dimensions			Package dimensions		
Unit dimensions	Height	mm(in)	1,235 (48 - 20 / 32)			1,326 (52 - 7 / 32)		
	Width	mm(in)	940 (37)			1,016 (40)		
	Depth	mm(in)	340 (13 - 12 / 32)			416 (16 - 12 / 32)		
Net weight		kg(lb)	120 (265)					
Shipping weight		kg(lb)	127 (280)					
Shipping volume		m ³ (Cu. ft.)	0.56 (19.8)					

Rated conditions

DATA SUBJECT TO CHANGE WITHOUT NOTICE.

Cooling: Indoor air temperature 27 °C DB / 19.0 °C WB

, Outdoor air temperature 35 °C DB

Heating: Indoor air temperature 20 °C DB

, Outdoor air temperature 7 °C DB / 6 °C WB

* Full load conditions at Indoor / outdoor capacity ratio 100 %

Cooling: Indoor air temperature 32 °C DB / 22.5 °C WB

, Outdoor air temperature 43 °C DB / 25.5 °C WB

1. Outdoor Unit

Unit specifications (B)

MODEL No.	Outdoor Unit		SPW – CR363GV8		
POWER SOURCE			380 - 400 - 415 V / 3 N / 50Hz		
PERFORMANCE			Cooling		
Capacity		kW BTU / h	11.2 38,200		
Air circulation (Hi)	m ³ /min(cu. ft/min)		84 (2,970)		
ELECTRICAL RATINGS					
Voltage rating	V		380	400	415
Available voltage range	V		342 - 456		
Running amperes	A		7.9	7.9	7.9
Max. running amperes*	A		9.0	8.9	8.7
Power input	kW		4.62	4.60	4.64
Max. power input*	kW		5.22	5.18	5.13
Power factor	%		89	84	82
C.O.P	W/W		2.42	2.43	2.41
Compressor locked rotor amperes	A		51	53	55
FEATURES					
Controls			Microprocessor		
Defrost control			Reverse cycle, microprocessor control		
Service function			Sensor temp. recall function Past service warnings recall function		
Refrigerant amount at shipment	kg		R407C - 3.4		
Refrigerant control			Electronic expansion valve		
Operation sound (Hi)	dB-A		55		
External finish			Galvanized steel plate with powder paint		
Color (Approximate value)			Munsell 5Y8.4 / 0.5, RAL 9002-GL		
REFRIGERANT TUBING					
Limit of tubing length	m(ft.)		70 (230)		
Limit of elevation difference between the two units	m(ft.)		Outdoor unit is higher than indoor unit : 40 (131) Outdoor unit is lower than indoor unit : 30 (98)		
Refrigerant tube outer diameter	Narrow tube	mm (in)	9.52 (3 / 8)		
	Wide tube	mm (in)	19.05 (3 / 4)		
Refrigerant tubing kit / joint kit			Optional		
DIMENSIONS & WEIGHT			Unit dimensions	Package dimensions	
Unit dimensions	Height	mm(in)	1,235 (48 - 20/32)		1,326 (52 - 7/32)
	Width	mm(in)	940 (37)		1,016 (40)
	Depth	mm(in)	340 (13 - 12/32)		416 (16 - 12/32)
Net weight	kg(lb)	118 (260)			
Shipping weight	kg(lb)	125 (276)			
Shipping volume	m ³ (Cu. ft.)	0.56 (19.8)			

Rated conditions

DATA SUBJECT TO CHANGE WITHOUT NOTICE.

Cooling: Indoor air temperature 27 °C DB / 19.0 °C WB , Outdoor air temperature 35 °C DB

* Full load conditions at Indoor / outdoor capacity ratio 100 %

Cooling: Indoor air temperature 32 °C DB / 22.5 °C WB , Outdoor air temperature 43 °C DB / 25.5 °C WB



Unit specifications (C)

MODEL No.		Outdoor Unit		SPW – CR483GVH8					
POWER SOURCE				380 - 400 - 415 V / 3 N / 50Hz					
PERFORMANCE				Cooling			Heating		
Capacity		kW BTU / h		14 47,800			16 54,600		
Air circulation (Hi)		m³/min(cu. ft/min)		84 (2,970)					
ELECTRICAL RATINGS									
Voltage rating		V		380	400	415	380	400	415
Available voltage range		V		342 - 456					
Running amperes		A		9.5	9.5	9.4	9.0	8.9	8.9
Max. running amperes*		A		10.4	10.2	10.1	–	–	–
Power input		kW		5.54	5.61	5.65	5.30	5.27	5.32
Max. power input*		kW		6.03	6.05	6.05	–	–	–
Power factor		%		89	85	84	90	86	83
C.O.P		W/W		2.53	2.5	2.48	3.02	3.04	3.01
Compressor locked rotor amperes		A		62	65	67	62	65	67
FEATURES									
Controls				Microprocessor					
Defrost control				Reverse cycle, microprocessor control					
Service function				Sensor temp. recall function Past service warnings recall function					
Refrigerant amount at shipment		kg		R407C - 3.6					
Refrigerant control				Electronic expansion valve					
Operation sound (Hi)		dB-A		55					
External finish				Galvanized steel plate with powder paint					
Color (Approximate value)				Munsell 5Y8.4 / 0.5, RAL 9002-GL					
REFRIGERANT TUBING									
Limit of tubing length		m(ft.)		70 (230)					
Limit of elevation difference between the two units		m(ft.)		Outdoor unit is higher than indoor unit : 40 (131) Outdoor unit is lower than indoor unit : 30 (98)					
Refrigerant tube outer diameter		Narrow tube mm (in)		9.52 (3 / 8)					
		Wide tube mm (in)		19.05 (3 / 4)					
Refrigerant tubing kit / joint kit				Optional					
DIMENSIONS & WEIGHT				Unit dimensions			Package dimensions		
Unit dimensions		Height mm(in)		1,235 (48 - 20 / 32)			1,326 (52 - 7 / 32)		
		Width mm(in)		940 (37)			1,016 (40)		
		Depth mm(in)		340 (13 - 12 / 32)			416 (16 - 12 / 32)		
Net weight		kg(lb)		120 (265)					
Shipping weight		kg(lb)		127 (280)					
Shipping volume		m³(Cu. ft.)		0.56 (19.8)					

Rated conditions

DATA SUBJECT TO CHANGE WITHOUT NOTICE.

Cooling: Indoor air temperature 27 °C DB / 19.0 °C WB , Outdoor air temperature 35 °C DB
 Heating: Indoor air temperature 20 °C DB , Outdoor air temperature 7 °C DB / 6 °C WB

* Full load conditions at Indoor / outdoor capacity ratio 130 %

Cooling: Indoor air temperature 32 °C DB / 22.5 °C WB , Outdoor air temperature 43 °C DB / 25.5 °C WB

Unit specifications (D)

1

MODEL No.		Outdoor Unit		SPW – CR483GV8		
POWER SOURCE				380 - 400 - 415 V / 3 N / 50Hz		
PERFORMANCE				Cooling		
Capacity		kW BTU / h		14 47,800		
Air circulation (Hi)		m ³ /min(cu. ft/min)		84 (2,790)		
ELECTRICAL RATINGS						
Voltage rating		V		380	400	415
Available voltage range		V		342 - 456		
Running amperes		A		9.5	9.5	9.4
Max. running amperes*		A		10.4	10.2	10.1
Power input		kW		5.54	5.61	5.65
Max. power input*		kW		6.03	6.05	6.05
Power factor		%		89	85	84
C.O.P		W/W		2.53	2.5	2.48
Compressor locked rotor amperes		A		62	65	67
FEATURES						
Controls		Microprocessor				
Defrost control		Reverse cycle, microprocessor control				
Service function		Sensor temp. recall function Past service warnings recall function				
Refrigerant amount at shipment		kg		R407C - 3.6		
Refrigerant control		Electronic expansion valve				
Operation sound (Hi)		dB-A		55		
External finish		Galvanized steel plate with powder paint				
Color (Approximate value)		Munsell 5Y8.4 / 0.5, RAL 9002-GL				
REFRIGERANT TUBING						
Limit of tubing length		m(ft.)		70 (230)		
Limit of elevation difference between the two units		m(ft.)		Outdoor unit is higher than indoor unit : 40 (131) Outdoor unit is lower than indoor unit : 30 (98)		
Refrigerant tube outer diameter		Narrow tube mm (in)		9.52 (3 / 8)		
		Wide tube mm (in)		19.05 (3 / 4)		
Refrigerant tubing kit / joint kit		Optional				
DIMENSIONS & WEIGHT				Unit dimensions		Package dimensions
Unit dimensions		Height mm(in)		1,235 (48 - 20/32)		1,326 (52 - 7/32)
		Width mm(in)		940 (37)		1,016 (40)
		Depth mm(in)		340 (13 - 12/32)		416 (16 - 12/32)
Net weight		kg(lb)		118 (260)		
Shipping weight		kg(lb)		125 (276)		
Shipping volume		m ³ (Cu. ft.)		0.56 (19.8)		

Rated conditions

DATA SUBJECT TO CHANGE WITHOUT NOTICE.

Cooling: Indoor air temperature 27 °C DB / 19.0 °C WB , Outdoor air temperature 35 °C DB

* Full load conditions at Indoor / outdoor capacity ratio 130 %

Cooling: Indoor air temperature 32 °C DB / 22.5 °C WB , Outdoor air temperature 43 °C DB / 25.5 °C WB

1. Outdoor Unit

Unit specifications (E)

MODEL No.	Outdoor Unit		SPW – CR703GVH8	
POWER SOURCE			380 - 400 - 415 V / 3 phase / 50Hz	
PERFORMANCE			Cooling	Heating
Capacity		kW BTU / h	22.4 76,400	25.0 85,300
Air circulation (Hi)	m ³ /min(cu. ft/min)		155 (5,470)	
ELECTRICAL RATINGS				
Voltage rating	V		380 - 400 - 415	
Available voltage range	V		342 - 456	
Running amperes	A		15.8 - 15.2 - 14.9	14.2 - 13.7 - 13.5
Max. running amperes*	A		20.6 - 19.6 - 19.2	—
Power input	kW		9.45 - 9.50 - 9.56	8.52 - 8.57 - 8.62
Max. power input*	kW		12.1 - 12.2 - 12.4	—
Power factor	%		90.9 - 90.2 - 89.3	91.2 - 90.3 - 88.8
C.O.P	W/W		2.37 - 2.36 - 2.34	2.93 - 2.92 - 2.9
Compressor locked rotor amperes	A		51 - 53 - 55	
FEATURES				
Controls	Microprocessor			
Defrost control	Reverse cycle, microprocessor control			
Service function	Sensor temp. recall function Past service warnings recall function			
Refrigerant amount at shipment	kg		R407C - 9.5	
Refrigerant control	Electronic expansion valve			
Operation sound (Hi)	dB-A		58	
Compressor	Super power control twin rotary compressor			
Color (Approximate value)	Munsell 5Y8.4 / 0.5, RAL 9002-GL			
REFRIGERANT TUBING				
Limit of tubing length	m(ft.)		100 (328)	
Limit of elevation difference between the two units	m(ft.)		Outdoor unit is higher than indoor unit : 50 (165) Outdoor unit is lower than indoor unit : 30 (100)	
Refrigerant tube outer diameter	Narrow tube	mm (in)	12.7 (1 / 2)	
	Wide tube	mm (in)	25.4 (1)	
Refrigerant tubing kit / joint kit	Optional			
DIMENSIONS & WEIGHT				
Unit dimensions	Height	mm(in)	1,218 (48)	1,351 (53 - 1 / 4)
	Width	mm(in)	883 (34 - 3 / 4)	1,047 (41 - 1 / 4)
	Depth	mm(in)	883 (34 - 3 / 4)	1,005 (39 - 5 / 8)
Net weight	kg(lb)		231 (510)	
Shipping weight	kg(lb)		234 (516)	
Shipping volume	m ³ (Cu. ft.)		1.42 (50.1)	

Rated conditions

Cooling: Indoor air temperature 27 °C DB / 19.0 °C WB , Outdoor air temperature 35 °C DB
 Heating: Indoor air temperature 20 °C DB , Outdoor air temperature 7 °C DB / 6 °C WB

* Full load conditions at Indoor / outdoor capacity ratio 130 %

Cooling: Indoor air temperature 32 °C DB / 22.5 °C WB , Outdoor air temperature 43 °C DB / 25.5 °C WB

DATA SUBJECT TO CHANGE WITHOUT NOTICE.



1. Outdoor Unit

Unit specifications (F)

MODEL No.	Outdoor Unit		SPW – CR703GV8	
POWER SOURCE			380 - 400 - 415 V / 3 phase / 50Hz	
PERFORMANCE			Cooling	
Capacity		kW BTU / h	22.4 76,400	
Air circulation (Hi)		m ³ /min(cu. ft/min)	155 (5,470)	
ELECTRICAL RATINGS				
Voltage rating		V	380 - 400 - 415	
Available voltage range		V	342 - 456	
Running amperes		A	15.8 - 15.2 - 14.9	
Max. running amperes*		A	20.6 - 19.6 - 19.2	
Power input		kW	9.45 - 9.50 - 9.56	
Max. power input*		kW	12.1 - 12.2 - 12.4	
Power factor		%	90.9 - 90.2 - 89.3	
C.O.P		W/W	2.37 - 2.36 - 2.34	
Compressor locked rotor amperes		A	51 - 53 - 55	
FEATURES				
Controls			Microprocessor	
Defrost control			Reverse cycle, microprocessor control	
Service function			Sensor temp. recall function Past service warnings recall function	
Refrigerant amount at shipment		kg	R407C - 9.5	
Refrigerant control			Electronic expansion valve	
Operation sound (Hi)		dB-A	58	
Compressor			Super power control twin rotary compressor	
Color (Approximate value)			Munsell 5Y8.4 / 0.5, RAL 9002-GL	
REFRIGERANT TUBING				
Limit of tubing length		m(ft.)	100 (328)	
Limit of elevation difference between the two units		m(ft.)	Outdoor unit is higher than indoor unit : 50 (165) Outdoor unit is lower than indoor unit : 30 (100)	
Refrigerant tube outer diameter	Narrow tube	mm (in)	12.7 (1 / 2)	
	Wide tube	mm (in)	25.4 (1)	
Refrigerant tubing kit / joint kit			Optional	
DIMENSIONS & WEIGHT			Unit dimensions	Package dimensions
Unit dimensions	Height	mm(in)	1,218 (48)	1,351 (53 - 1 / 4)
	Width	mm(in)	883 (34 - 3 / 4)	1,047 (41 - 1 / 4)
	Depth	mm(in)	883 (34 - 3 / 4)	1,005 (39 - 5 / 8)
Net weight		kg(lb)	229 (505)	
Shipping weight		kg(lb)	229 (505)	
Shipping volume		m ³ (Cu. ft.)	1.42 (50.1)	

Rated conditions

DATA SUBJECT TO CHANGE WITHOUT NOTICE.

Cooling: Indoor air temperature 27 °C DB / 19.0 °C WB , Outdoor air temperature 35 °C DB

* Full load conditions at Indoor / outdoor capacity ratio 130 %

Cooling: Indoor air temperature 32 °C DB / 22.5 °C WB , Outdoor air temperature 43 °C DB / 25.5 °C WB

1. Outdoor Unit



Unit specifications (G)

MODEL No.		Outdoor Unit		SPW – CR903GVH8	
POWER SOURCE				380 - 400 - 415 V / 3 phase / 50Hz	
PERFORMANCE				Cooling	Heating
Capacity		kW BTU / h	28.0 95,500	31.5 107,500	
Air circulation (Hi)		m ³ /min(cu. ft/min)	150 (5,300)		
ELECTRICAL RATINGS					
Voltage rating		V	380 - 400 - 415		
Available voltage range		V	342 – 456		
Running amperes		A	18.8 - 18.3 - 18.0	17.5 - 17.0 - 16.9	
Max. running amperes*		A	24.2 - 23.6 - 23.1	—	
Power input		kW	11.3 - 11.4 - 11.5	10.4 - 10.6 - 10.8	
Max. power input*		kW	14.5 - 14.9 - 15.1	—	
Power factor		%	91.3 - 89.9 - 88.9	90.3 - 90 - 88.9	
C.O.P.		W/W	2.48 - 2.46 - 2.43	3.03 - 2.97 - 2.92	
Compressor locked rotor amperes		A	62 - 65 - 67		
FEATURES					
Controls			Microprocessor		
Defrost control			Reverse cycle, microprocessor control		
Service function			Sensor temp. recall function Past service warnings recall function		
Refrigerant amount at shipment		kg	R407C - 11.0		
Refrigerant control			Electronic expansion valve		
Operation sound (Hi)		dB-A	58		
Compressor			Super power control twin rotary compressor		
Color (Approximate value)			Munsell 5Y8.4 / 0.5, RAL 9002-GL		
REFRIGERANT TUBING					
Limit of tubing length		m(ft.)	100 (328)		
Limit of elevation difference between the two units		m(ft.)	Outdoor unit is higher than indoor unit : 50 (165) Outdoor unit is lower than indoor unit : 30 (100)		
Refrigerant tube outer diameter	Narrow tube	mm (in)	12.7 (1 / 2)		
	Wide tube	mm (in)	28.58 (1-1 / 8)		
Refrigerant tubing kit / joint kit			Optional		
DIMENSIONS & WEIGHT					
Unit dimensions			Unit dimensions	Package dimensions	
Unit dimensions	Height	mm(in)	1,218 (48)	1,351 (53 - 1 / 4)	
	Width	mm(in)	883 (34 - 3 / 4)	1,047 (41 - 1 / 4)	
	Depth	mm(in)	883 (34 - 3 / 4)	1,005 (39 - 5 / 8)	
Net weight		kg(lb)	243 (536)		
Shipping weight		kg(lb)	242 (534)		
Shipping volume		m ³ (cu. ft.)	1.42 (50.1)		

Rated conditions

DATA SUBJECT TO CHANGE WITHOUT NOTICE.

Cooling: Indoor air temperature 27 °C DB / 19.0 °C WB , Outdoor air temperature 35 °C DB
 Heating: Indoor air temperature 20 °C DB , Outdoor air temperature 7 °C DB / 6 °C WB

* Full load conditions at Indoor / outdoor capacity ratio 130 %

Cooling: Indoor air temperature 32 °C DB / 22.5 °C WB , Outdoor air temperature 43 °C DB / 25.5 °C WB

1. Outdoor Unit

Unit specifications (H)

MODEL No.	Outdoor Unit		SPW – CR903GV8	
POWER SOURCE			380 - 400 - 415 V / 3 phase / 50Hz	
PERFORMANCE			Cooling	
Capacity		kW BTU / h	28.0 95,500	
Air circulation (Hi)	m ³ /min(cu. ft/min)		150 (5,300)	
ELECTRICAL RATINGS				
Voltage rating		V	380 - 400 - 415	
Available voltage range		V	342 – 456	
Running amperes		A	18.8 - 18.3 - 18.0	
Max. running amperes*		A	24.2 - 23.6 - 23.1	
Power input		kW	11.3 - 11.4 - 11.5	
Max. power input*		kW	14.5 - 14.9 - 15.1	
Power factor		%	91.3 - 89.9 - 88.9	
C.O.P.		W/W	2.48 - 2.46 - 2.43	
Compressor locked rotor amperes		A	62 - 65 - 67	
FEATURES				
Controls	Microprocessor			
Defrost control	Reverse cycle, microprocessor control			
Service function	Sensor temp. recall function Past service warnings recall function			
Refrigerant amount at shipment		kg	R407C - 11.0	
Refrigerant control	Electronic expansion valve			
Operation sound (Hi)		dB-A	58	
Compressor	Super power control twin rotary compressor			
Color (Approximate value)	Munsell 5Y8.4 / 0.5, RAL 9002 - GL			
REFRIGERANT TUBING				
Limit of tubing length		m(ft.)	100 (328)	
Limit of elevation difference between the two units		m(ft.)	Outdoor unit is higher than indoor unit : 50 (165) Outdoor unit is lower than indoor unit : 30 (100)	
Refrigerant tube outer diameter	Narrow tube	mm (in)	12.7 (1 / 2)	
	Wide tube	mm (in)	28.58 (1-1 / 8)	
Refrigerant tubing kit / joint kit	Optional			
DIMENSIONS & WEIGHT				
Unit dimensions	Height	mm(in)	1,218 (48)	1,351 (53 - 1 / 4)
	Width	mm(in)	883 (34 - 3 / 4)	1,047 (41 - 1 / 4)
	Depth	mm(in)	883 (34 - 3 / 4)	1,005 (39 - 5 / 8)
Net weight		kg(lb)	241 (532)	
Shipping weight		kg(lb)	237 (522)	
Shipping volume		m ³ (cu. ft.)	1.42 (50.1)	

Rated conditions

DATA SUBJECT TO CHANGE WITHOUT NOTICE.

Cooling: Indoor air temperature 27 °C DB / 19.0 °C WB , Outdoor air temperature 35 °C DB

* Full load conditions at Indoor / outdoor capacity ratio 130 %

Cooling: Indoor air temperature 32 °C DB / 22.5 °C WB , Outdoor air temperature 43 °C DB / 25.5 °C WB

1. Outdoor Unit

1-2. Major component specifications

Outdoor Unit (A)

MODEL No.	SPW – CR363GVH8 / SPW – CR363GV8	
Source	380 - 400 - 415 V / 3 phase / 50Hz	
Controller P.C.B. Ass'y	CR - CR363GVH / CR - CR363GV	
Control circuit fuse	250 V , 3.15 A	
Compressor	Rotary (Hermetic)	
	PC (Power Control)	
Model ... Code No.	C-5RN373H8R ... 80838788	
Nominal output	kW	3.75
Compressor oil (ETHER FV68S)	cc	2,000
Coil resistance (Ambient temperature 25°C)	Ω	V - U: 2.83 , U - W: 2.65 W - V: 2.78
Safety devices		
Thermal protector ON / OFF	°C	120 ± 5 / 98 ± 11
Microprocessor safety devices	Compressor current detection circuit Compressor discharge gas temperature control Defective and negative phase detection circuit Voltage drop detection circuit	
Crank case heater	V, W	240, 32
High pressure switch	ACB - 1TB14W (TÜV Approved)	
Set pressure	ON / OFF kg/cm ²	23.5 ± 2.0 / 31.4 ⁺⁰ _{-1.5}
Fan (Number ... diameter(mm))	Propeller (2 ... ø 460)	
Fan motor		
Model ... Nominal output	W	KFC6T - 91C5P × 2 ... 70W × 2
No. of pole ... r.p.m. (230 V, High)	6 ... 772 r.p.m.	
Coil resistance (Ambient temperature 20 °C)	Ω	BRN - WHT : 127.3 WHT - VLT : 56.7 VLT - YEL : 15.0 YEL - PNK : 7.2
Safety device		
Thermal protector ON / OFF	°C	(79 ± 15) / 130 ± 8
Run capacitor	VAC , μF	440 V , 6 μF × 2
Heat exchanger		
Coil	Aluminum plate fin / Copper tube	
Rows ... fin pitch	mm	2 ... 2.0
Face area	m ²	1.08

1

1. Outdoor Unit

Outdoor Unit (B)

MODEL No.	SPW – CR483GVH8 / SPW – CR483GV8	
Source	380 - 400 - 415 V / 3 phase / 50Hz	
Controller P.C.B. Ass'y	CR - CR363GVH / CR - CR363GV	
Control circuit fuse	250 V , 3.15 A	
Compressor	Rotary (Hermetic)	
	PC (Power Control)	
Model ... Code No.	C-5RN433H8R ... 80844788	
Nominal output	kW	4.3
Compressor oil (ETHER FV68S)	cc	2,000
Coil resistance	Ω	V - U: 2.76 , U - W: 2.59
(Ambient temperature 25°C)		W - V: 2.71
Safety devices		
Thermal protector ON / OFF	°C	120 ± 5 / 98 ± 11
Microprocessor safety devices	Compressor current detection circuit Compressor discharge gas temperature control Defective and negative phase detection circuit Voltage drop detection circuit	
Crank case heater	V, W	240, 32
High pressure switch	ACB - 1TB14W (TÜV Approved)	
Set pressure	ON / OFF kg/cm ²	23.5 ± 2.0 / 31.4 ^{+0.5}
Fan (Number ... diameter(mm))	Propeller (2 ... ø 460)	
Fan motor		
Model ... Nominal output	W	KFC6T - 91C5P × 2 ... 70W × 2
No. of pole ... r.p.m. (230 V, High)		6 ... 772 r.p.m.
Coil resistance	Ω	BRN - WHT : 127.3 WHT - VLT : 56.7 VLT - YEL : 15.0 YEL - PNK : 7.2
(Ambient temperature 20 °C)		
Safety device		
Thermal protector ON / OFF	°C	(79 ± 15) / 130 ± 8
Run capacitor	VAC , μ F	440 V , 6 μ F × 2
Heat exchanger		
Coil	Aluminum plate fin / Copper tube	
Rows ... fin pitch	mm	2 ... 2.0
Face area	m ²	1.08

1. Outdoor Unit

Outdoor Unit (C)

MODEL No.	SPW – CR703GVH8 / SPW – CR703GV8	
Source	380 - 400 - 415 V / 3 phase / 50Hz	
Controller P.C.B. Ass'y	CR - CR703GVH / CR - CR703GV	
Control circuit fuse	250 V , 3.15 A	
Compressor	Rotary (Hermetic)	
	PC (Power Control)	AC (Standard)
Model ... Code No.	C-5RN373H8R ... 80838788	C-5RN373H8C ... 80838588
Nominal output kW	3.75	3.75
Compressor oil (ETHER FV68S) cc	2,000	2,000
Coil resistance Ω (Ambient temperature 25°C)	V - U: 2.83 , U - W: 2.65 W - V: 2.78	V - U: 2.83 , U - W: 2.65 W - V: 2.78
Safety devices		
Thermal protector ON / OFF °C	120 \pm 5 / 98 \pm 11	120 \pm 5 / 98 \pm 11
Microprocessor safety devices	Compressor current detection circuit Compressor discharge gas temperature control Defective and negative phase detection circuit Voltage drop detection circuit	
Crank case heater V, W	240 , 32	240 , 32
Fusible plug (Operating temp.) °C	73 \pm 2	
High pressure switch	ACB - 1TB14W (TÜV Approved)	
Set pressure ON / OFF kg/cm ²	23.5 \pm 2.0 / 31.4 ⁺⁰ _{-1.5}	
Fan (Number ... diameter(mm))	Propeller (1 ... \varnothing 750)	
Fan motor		
Model ... Nominal output W	KFJ8T - 301B3P ... 300 W	
No. of pole ... r.p.m. (230 V, High)	8 ... 576 r.p.m.	
Coil resistance Ω (Ambient temperature 20 °C)	BRN - WHT : 11.89 WHT - VLT : 4.156 VLT - YEL : 9.639 WHT - PNK : 12.51	
Safety device		
Thermal protector ON / OFF °C	(115 \pm 5) / 130 \pm 5	
Run capacitor VAC , μ F	400 V , 15.0 μ F	
Heat exchanger		
Coil	Aluminum plate fin / Copper tube	
Rows ... fin pitch mm	2 ... 1.7	
Face area m ²	2.40	

1

1. Outdoor Unit

Outdoor Unit (D)

MODEL No.	SPW – CR903GVH8 / SPW – CR903GV8	
Source	380 - 400 - 415 V / 3 phase / 50Hz	
Controller P.C.B. Ass'y	CR - CR703GVH / CR - CR703GV	
Control circuit fuse	250 V , 3.15 A	
Compressor	Rotary (Hermetic)	
	PC (Power Control)	AC (Standard)
Model ... Code No.	C-5RN433H8R ... 80844788	C-5RN433H8C ... 80844588
Nominal output kW	4.3	4.3
Compressor oil (ETHER FV68S) cc	2,000	2,000
Coil resistance Ω (Ambient temperature 25°C)	V - U: 2.76 , U - W: 2.59 W - V: 2.71	V - U: 2.76 , U - W: 2.59 W - V: 2.71
Safety devices		
Thermal protector ON / OFF °C	120 ± 5 / 98 ± 11	120 ± 5 / 98 ± 11
Microprocessor safety devices	Compressor current detection circuit Compressor discharge gas temperature control Defective and negative phase detection circuit Voltage drop detection circuit	
Crank case heater V, W	240 , 32	240 , 32
Fusible plug (Operating temp.) °C	73 ± 2	
High pressure switch	ACB - 1TB14W (TÜV Approved)	
Set pressure ON / OFF kg/cm ²	24 ± 2.0 / 33 ± _{1.5} ⁰	
Fan (Number ... diameter(mm))	Propeller (1 ... ø 750)	
Fan motor		
Model ... Nominal output W	KFJ8T - 301B3P ... 300W	
No. of pole ... r.p.m. (230 V, High)	8 ... 601 r.p.m.	
Coil resistance Ω (Ambient temperature 20 °C)	BRN - WHT : 11.89 WHT - VLT : 4.156 VLT - YEL : 9.639 WHT - PNK : 12.51	
Safety device		
Thermal protector ON / OFF °C	(115 ± 5) / 130 ± 5	
Run capacitor VAC , μ F	400 V , 17.5 μ F	
Heat exchanger		
Coil	Aluminum plate fin / Copper tube	
Rows ... fin pitch mm	2 ... 1.7	
Face area m ²	2.40	

1. Outdoor Unit

1-3. Control specifications

MODEL No.	Outdoor Unit		SPW – CR363GVH8 / SPW – CR363GV8 SPW – CR483GVH8 / SPW – CR483GV8 SPW – CR703GVH8 / SPW – CR703GV8 SPW – CR903GVH8 / SPW – CR903GV8
Thermostat	Available Setting temp.	Cooling	18 – 30 °C
		Dry	18 – 30 °C
		Heating	16 – 26 °C
Mode setting	Operation mode		HEAT* • DRY • COOL • FAN
	Fan speed		Auto • Hi • Med • Lo
	Timer		ON • OFF • (Max. 72 hour)
	Auto. flap		Fan Aim / Sweep
Alarm message	Serial communication		E1 – E 7
	Improper address setting & others		E8 – E18
	Activation of protective device		P1 – P17
	Thermistor failure		F1 – F11
	Fault with comp. & its circuit		H1 – H13 , F27 , F28
Compressor contactor (Mg SW) abnormal			H9 & H19
*Cold draft prevention	Timer		–
	Indoor unit coil temp. E2 < 27 °C		
Defrosting control*	Reverse cycle, microprocessor control		
Service function	Sensor temp. recall function		
	Past service warnings recall function (Max. 4 alarms)		
System control	Multiple remote control		Max. 2 controllers (Main : 1, Sub: 1)
	Group control		Simultaneous operation Max. 8 units
Automatic restart after power interruption			
Test run function (built in 60 min. timer)			

*: Only for heat pump type.

1. Outdoor Unit

1-4. Other component specifications

MODEL No.	Outdoor Unit	SPW – CR363GVH8 / SPW – CR363GV8 SPW – CR483GVH8 / SPW – CR483GV8	
Power Transformer		ATR-II335, CT CL-4	
Thermostat (Option)	Available setting temp.	Cooling	18 – 30 °C
		Dry	18 – 30 °C
		Heating	16 – 26 °C
Thermistor (Coil sensor)		PBC-41E-S4 , PBC-41E-S36 , PBC-4E-S25	
Resistance	KΩ	-10 °C : 23.7 ± 5 % , 20 °C : 6.5 ± 5 % -5 °C : 18.8 ± 5 % , 30 °C : 4.4 ± 5 % 0 °C : 15.0 ± 5 % , 40 °C : 3.1 ± 5 % 5 °C : 12.1 ± 5 % , 45 °C : 2.6 ± 5 % 10 °C : 9.7 ± 5 %	
Thermistor (Discharge gas sensor or coil sensor)		PTC-51H	
Resistance	KΩ	60 °C : 13.8 ± 5 % , 90 °C : 5.1 ± 5 % 70 °C : 9.7 ± 5 % , 100 °C : 3.8 ± 5 % 75 °C : 8.2 ± 5 % , 110 °C : 2.8 ± 5 % 80 °C : 7.0 ± 5 % , 120 °C : 2.2 ± 5 % 85 °C : 5.9 ± 5 % , 130 °C : 1.7 ± 5 %	
Relay		FMCA-15Z607 , FC-1SZ607	
Coil rated	V	AC 220 V - 240 V	
Contact rating	V.A	AC 440 V, 13 A	
Coil Resistance (at 25 °C)	kΩ	—	
Solenoid valve			
Valve body		NEV-152DXFQ8 / NEV-603DXF / NEV-202DXF	
Coil		NEV-MOAJ504B0 / NEV-MOAJ533B1	
Reversing valve or coil		(only heat pump type)	
Reversing valve		CHV 0401	
Solenoid coil		CHV 01AJ504D1	

1. Outdoor Unit

MODEL No.	Outdoor Unit	SPW – CR703GVH8 / SPW – CR703GV8 SPW – CR903GVH8 / SPW – CR903GV8	
Power Transformer		ATR-II335, CT CL-4	
Thermostat (Option)	Available setting temp.	Cooling	18 – 30 °C
		Dry	18 – 30 °C
		Heating	16 – 26 °C
Thermistor (Coil sensor)		PBC-41E-S4 , PBC-41E-S36 , PBC-41E-S40N	
Resistance	KΩ	-10 °C : 23.7 ± 5 % , 20 °C : 6.5 ± 5 % -5 °C : 18.8 ± 5 % , 30 °C : 4.4 ± 5 % 0 °C : 15.0 ± 5 % , 40 °C : 3.1 ± 5 % 5 °C : 12.1 ± 5 % , 45 °C : 2.6 ± 5 % 10 °C : 9.7 ± 5 %	
Thermistor (Discharge gas sensor or coil sensor)		PTC-51H	
Resistance	KΩ	60 °C : 13.8 ± 5 % , 90 °C : 5.1 ± 5 % 70 °C : 9.7 ± 5 % , 100 °C : 3.8 ± 5 % 75 °C : 8.2 ± 5 % , 110 °C : 2.8 ± 5 % 80 °C : 7.0 ± 5 % , 120 °C : 2.2 ± 5 % 85 °C : 5.9 ± 5 % , 130 °C : 1.7 ± 5 %	
Power Relay		HH62S	
Coil rated	V	AC 220 V - 240 V	
Contact rating	V.A	240 VAC, 10 A	
Coil Resistance (at 20 °C)	kΩ	17.2 ± 10 %	
Solenoid valve			
Valve body		NEV-603DXF / NEV-202DXF / NEV-152DXFQ8	
Coil		EKV-MOZS559E0	
Reversing valve or coil		(only heat pump type)	
Reversing valve		VH 60100	
Solenoid coil		LB 60022	

1

1. Outdoor Unit

1-5. Dimensional data

Diagram of ECO MULTI Outer Dimensions

SPW-CR363GVH8 / CR363GV8
 SPW-CR483GVH8 / CR483GV8

①	Hole for anchor bolt (4 - $\phi 13$)
②	Refrigerant tube joint (narrow tube) Flare connection 3/8 in (9.52 mm)
③	Refrigerant tube joint (wide tube) Flare connection 3/8 in (19.05 mm)
④	Refrigerant tubing inlet
⑤	Power supply inlet

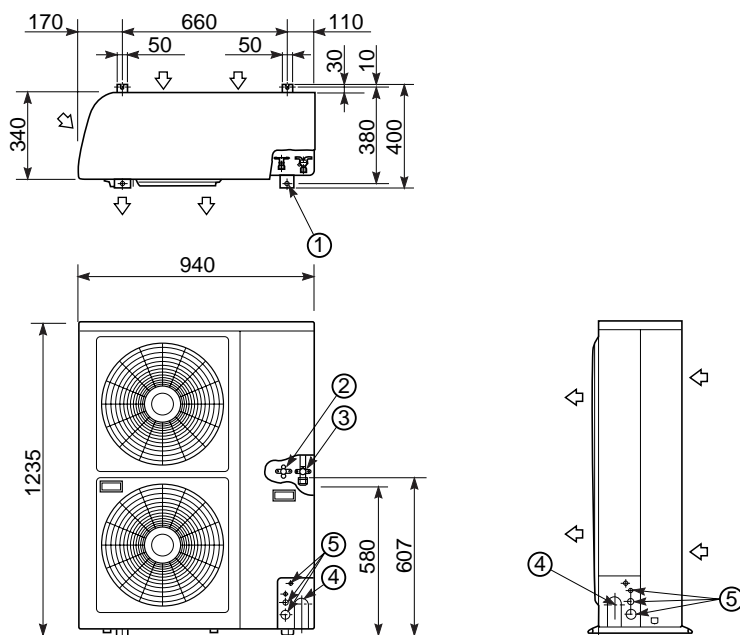

1239_C_I

SPW-CR703GVH8 / CR703GV8
 SPW-CR903GVH8 / CR903GV8

①	Installation hole (4 - $\phi 15$ hole)
②	Refrigerant liquid line $\phi 12.7$ (narrow tube) flare connection
③	Refrigerant gas line (wide tube) 90 type: $\phi 28.58$ 70 type: $\phi 25.4$ Brazing connection
④	Knock out hole for power supply, inter-unit wiring (Front side)
⑤	Power supply, inter-unit wiring openings (Bottom side) $\phi 60, \phi 38$ conduit connection

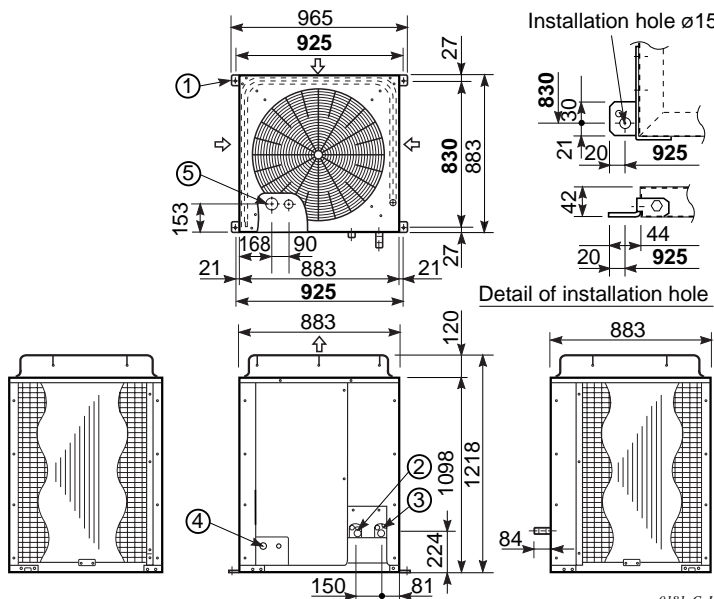

0181_C_I

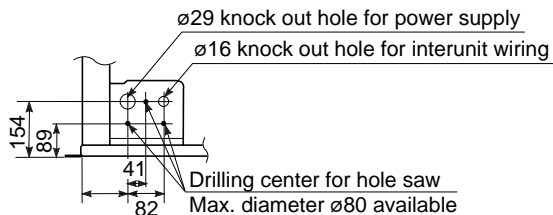

1. Outdoor Unit

1-6. Refrigerant flow diagram

SPW-CR363GVH8, SPW-CR483GVH8 (Heat pump)

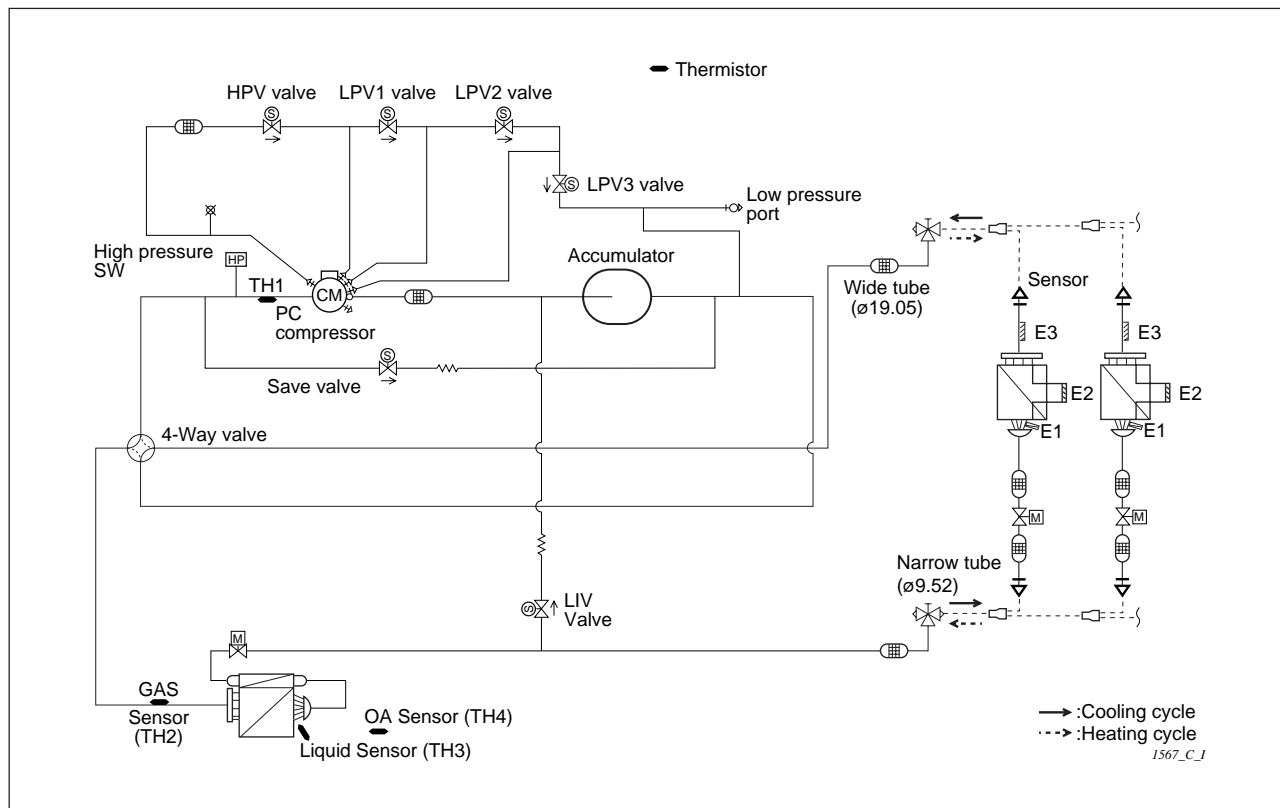

SPW-CR363GV8, SPW-CR483GV8 (Cooling only type)

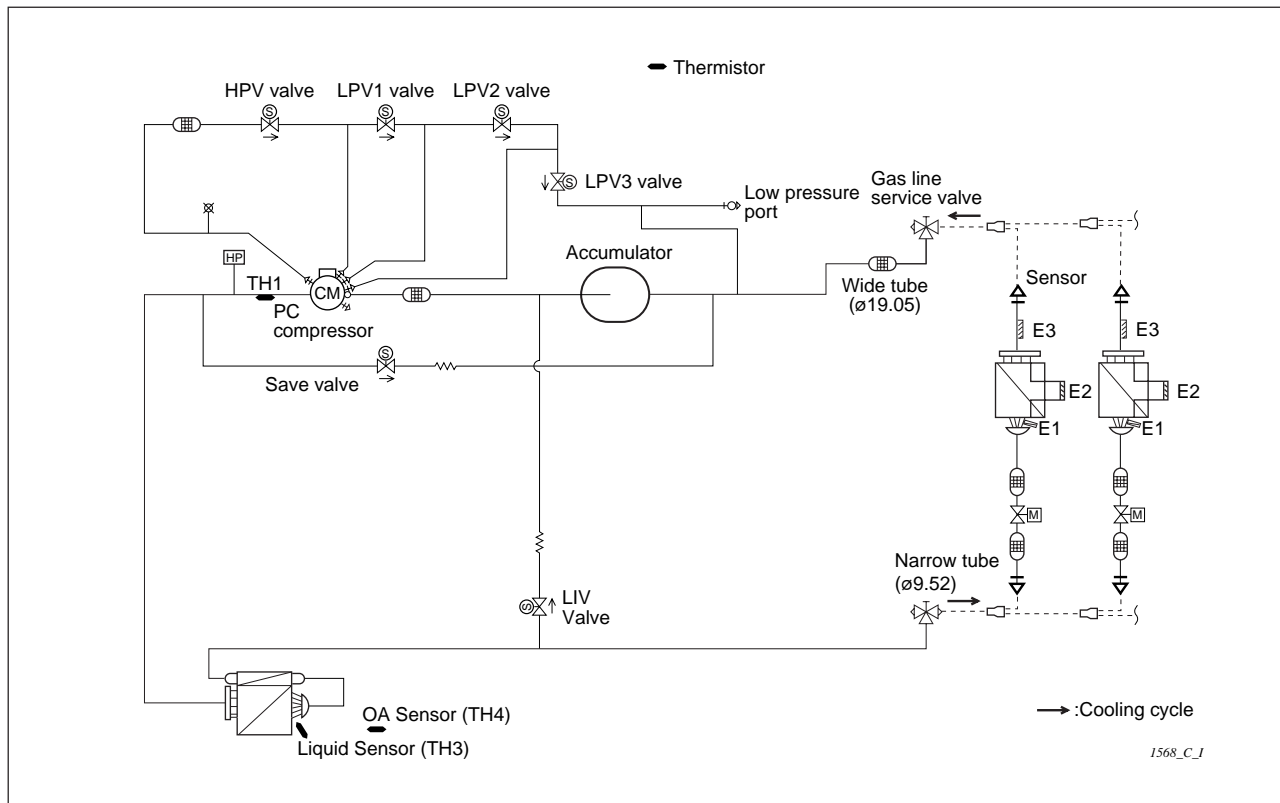

1. Outdoor Unit

SPW-CR703GVH8, CR903GVH8 (Heat pump only)

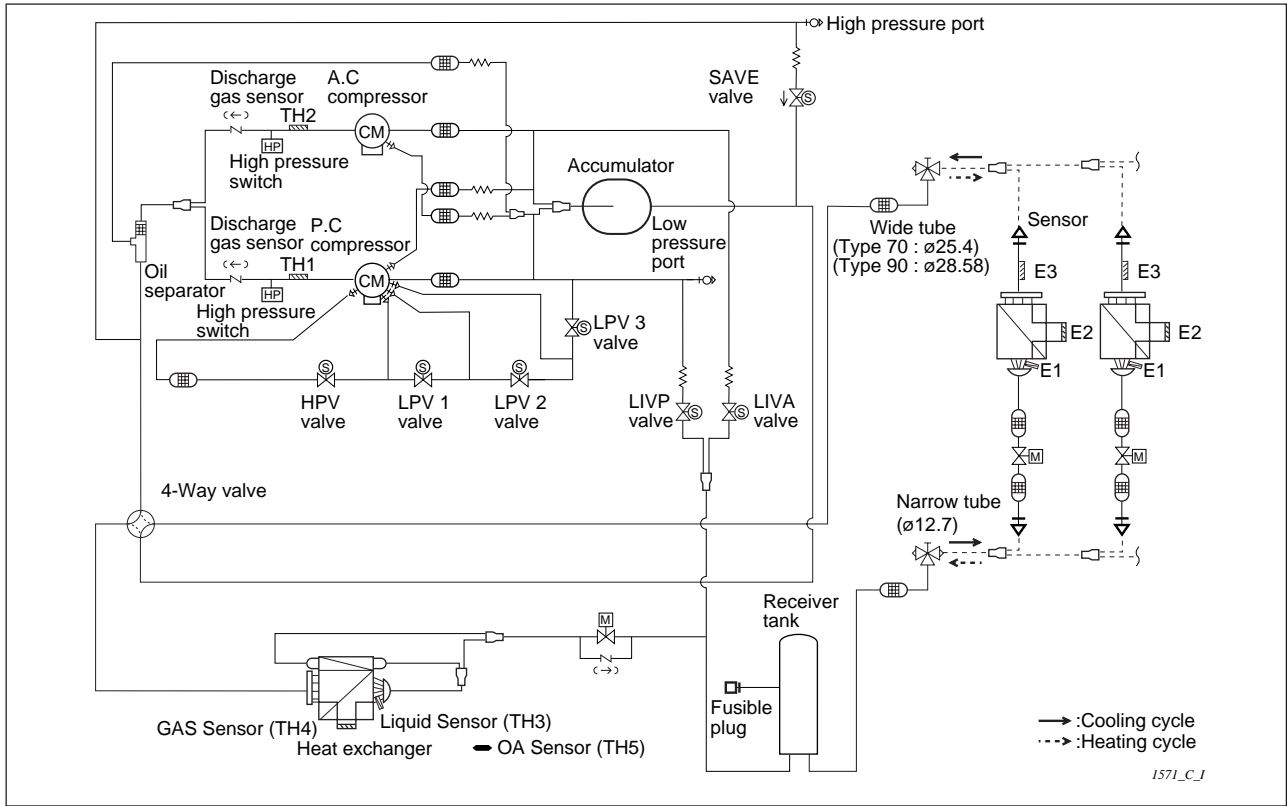

SPW-CR703GV8, CR903GV8 (Cooling only type)

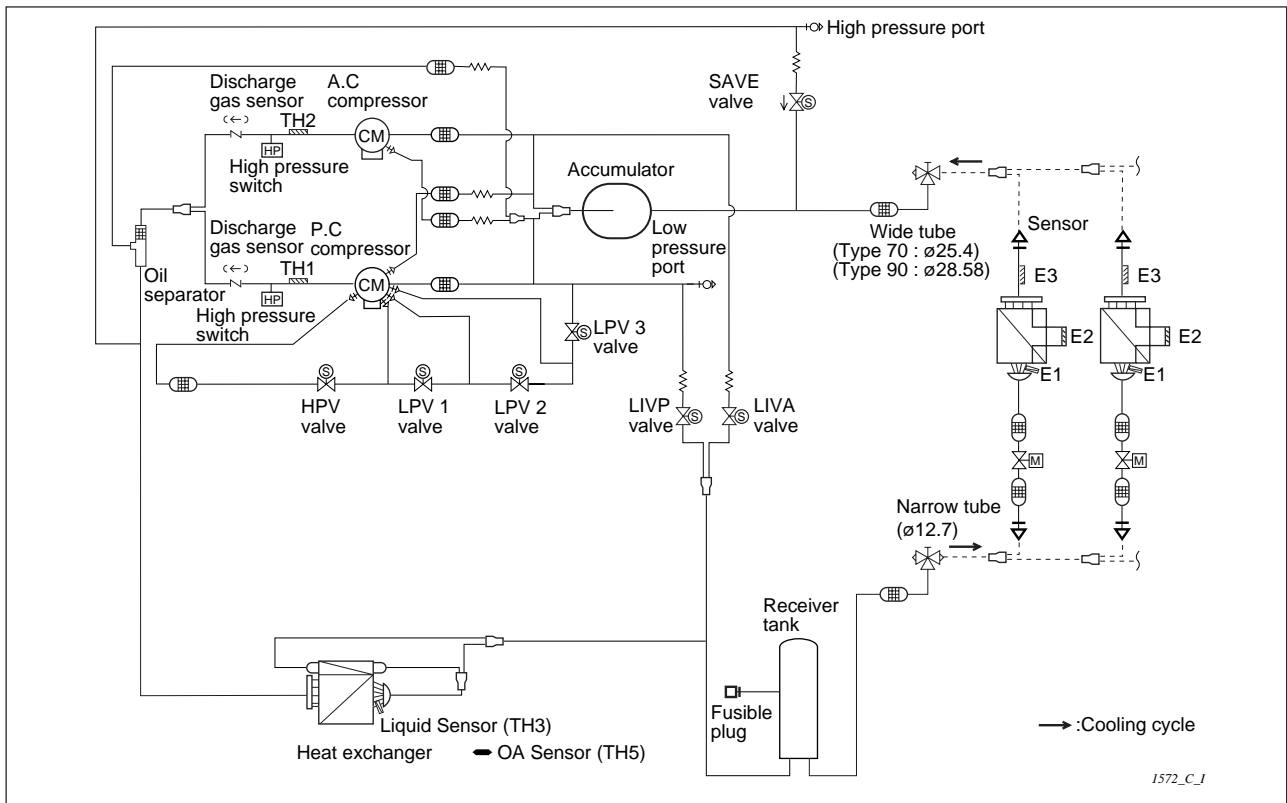

1. Outdoor Unit

1-7. Noise criterion curves

MODEL : SPW-CR363GVH8 , CR363GV8
 SOUND LEVEL : 54 dB(A), NC 45
 CONDITION : Distance 1 m, Height 1 m
 SOURCE : 220 - 230 - 240 V, 1 Phase, 50 Hz
 380 - 400 - 415 V, 3 Phase, 50 Hz

MODEL : SPW-CR483GVH8 , CR483GV8
 SOUND LEVEL : 56 dB(A), NC 47
 CONDITION : Distance 1 m, Height 1 m
 SOURCE : 380 - 400 - 415 V, 3 Phase, 50 Hz

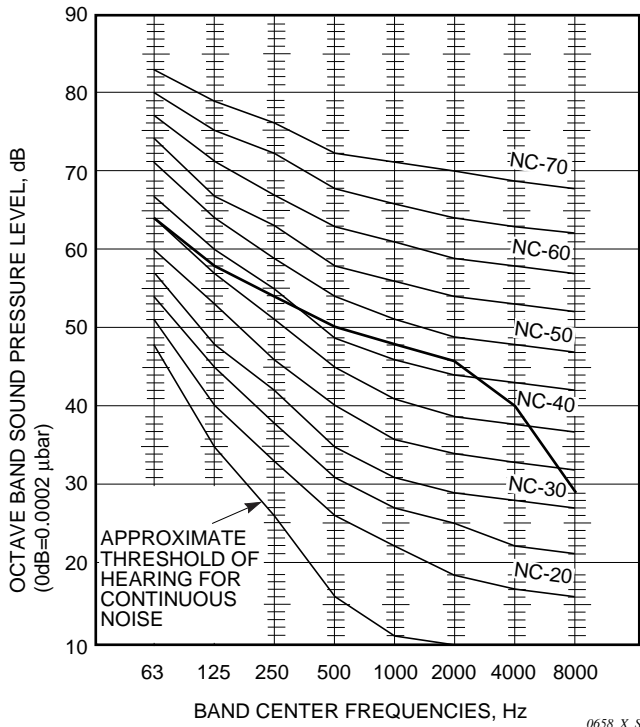
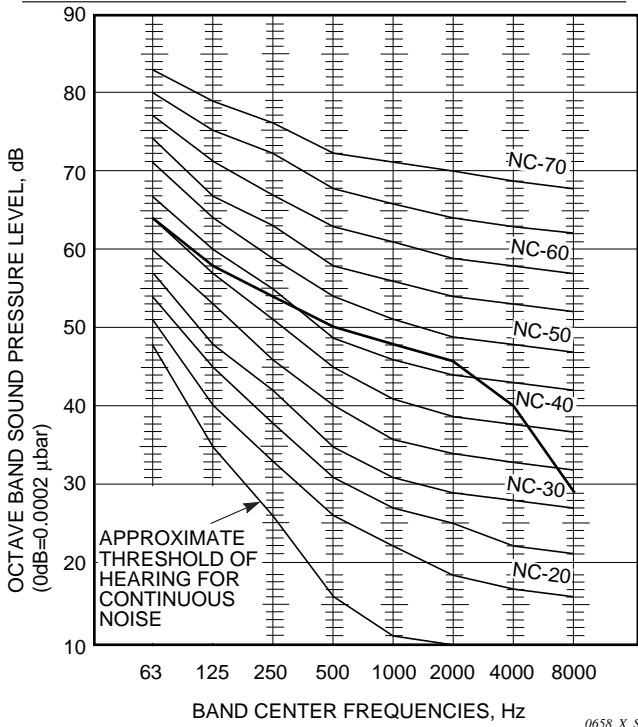

MODEL : SPW-CR703GVH8 , CR703GV8
 SOUND LEVEL : HIGH 58 dB(A), NC 52
 CONDITION : Height 1 m, distance 1 m
 SOURCE : 380 / 400 / 415 V, 3 Phase, 50 Hz

MODEL : SPW-CR903GVH8 , CR903GV8
 SOUND LEVEL : HIGH 58 dB(A), NC 52
 CONDITION : Height 1 m, distance 1 m
 SOURCE : 380 / 400 / 415 V, 3 Phase, 50 Hz

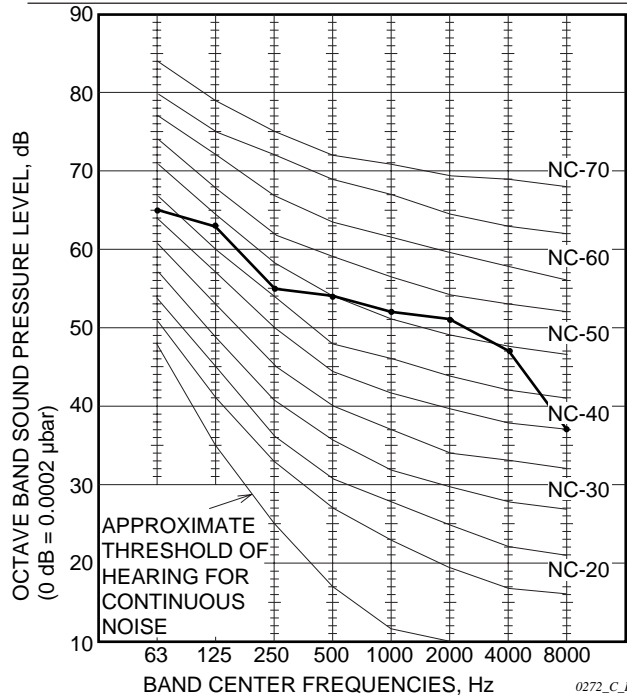
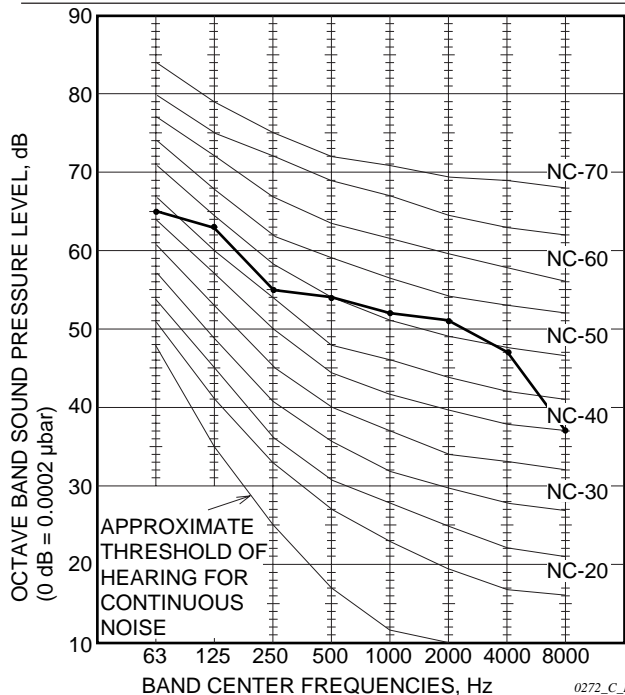

2. 4-Way Air Discharge Semi-concealed Type

2-1. Specifications

Unit specifications (A)

MODEL No.		Indoor Unit		SPW-XR123GH56			
POWER SOURCE				220 - 230 - 240 V / 1 phase – 50Hz			
PERFORMANCE				Cooling		Heating	
Capacity		kW BTU / h	3.6 12,000	4.2 14,000			
Air circulation (Hi / Me / Lo)		m ³ /h	900 / 780 / 660				
Moisture removal (High)		Liters/h	0.9	—			
ELECTRICAL RATINGS							
Voltage rating		V	220 - 230 - 240				
Available voltage range		V	198 – 264				
Running amperes		A	0.60 - 0.62 - 0.63	0.37 - 0.40 - 0.42			
Power input		W	130 - 140 - 150	80 - 90 - 100			
Power factor		%	98 - 98 - 99	98 - 98 - 99			
Fan motor locked rotor amperes		A	1 - 1 - 1				
FEATURES							
Controls		Microprocessor					
Timer		ON / OFF Timer (Max. 72 hr)					
Fan speeds		3 and Automatic control					
Air filter		Washable, easy access, long life (2,500 hr)					
Refrigerant control		Electronic expansion valve					
Operation sound (Hi / Me / Lo)		dB-A	37 / 35 / 30				
Refrigerant tubing connections		Flare type					
Refrigerant tube diameter	Narrow tube mm (in.)	9.52 (3 / 8)					
	Wide tube mm (in.)	12.7 (1 / 2)					
Drain connection		25 A, OD32 mm					
Drain pump		Max. head 25 cm above drain connection					
Panel		Optional (PNR-X253GHA)					
Remote Controller		Optional (RCS-SH80TG)					
Refrigerant tubing kit / Accessories		Optional / —					
Color (Approximate value)		Munsell 10Y9.3 / 0.4, RAL 9010-GL					
DIMENSIONS & WEIGHT				Indoor unit (include panel)		Package	
Dimensions	Height	mm (in.)	328 (12 - 29 / 32)	284 (11 - 6 / 32)	104 (4 - 3 / 32)		
	Width	mm (in.)	860 (33 - 27 / 32)	824 (32 - 14 / 32)	967 (38 - 2 / 32)		
	Depth	mm (in.)	860 (33 - 27 / 32)	833 (32 - 25 / 32)	999 (39 - 11 / 32)		
Net weight		kg (lb.)	29 (64)	—		—	
Shipping weight		kg (lb.)	—	26 (57)	8 (18)		
Shipping volume		m ³ (cu. ft)	—	0.195 (6.9)	0.1 (3.5)		

DATA SUBJECT TO CHANGE WITHOUT NOTICE.

Rated conditions

Cooling: Indoor air temperature 27 °C DB / 19 °C WB, Outdoor air temperature 35 °C DB

Heating: Indoor air temperature 20 °C DB , Outdoor air temperature 7 °C DB / 6 °C WB

SM830063

2. 4-Way Air Discharge Semi-concealed Type

Unit specifications (B)

MODEL No.	Indoor Unit		SPW-XR183GH56		
POWER SOURCE	220 - 230 - 240 V / 1 phase / 50Hz				
PERFORMANCE			Cooling	Heating	
Capacity	kW		5.6	6.3	
	BTU / h		19,000	21,000	
Air circulation (Hi / Me / Lo)	m ³ /h		900 / 780 / 660		
Moisture removal (High)	Liters/h		2.6	—	
ELECTRICAL RATINGS					
Voltage rating	V		220 - 230 - 240		
Available voltage range	V		198 - 264		
Running amperes	A		0.60 - 0.62 - 0.63	0.37 - 0.40 - 0.42	
Power input	W		130 - 140 - 150	80 - 90 - 100	
Power factor	%		98 - 98 - 99	98 - 98 - 99	
Fan motor locked rotor amperes	A		1 - 1 - 1		
FEATURES					
Controls	Microprocessor				
Timer	ON / OFF Timer (Max. 72 hr)				
Fan speeds	3 and Automatic control				
Air filter	Washable, easy access, long life (2,500 hr)				
Refrigerant control	Electronic expansion valve				
Operation sound (Hi / Me / Lo)	dB-A		37 / 35 / 30		
Refrigerant tubing connections	Flare type				
Refrigerant tube diameter	Narrow tube mm (in.)		9.52 (3 / 8)		
	Wide tube mm (in.)		15.88 (5 / 8)		
Drain connection	25 A, OD32 mm				
Drain pump	Max. head 25 cm above drain connection				
Panel	Optional (PNR-X253GHA)				
Remote Controller	Optional (RCS-SH80TG)				
Refrigerant tubing kit / Accessories	Optional / —				
Color (Approximate value)	Munsell 10Y9.3 / 0.4, RAL 9010-GL				
DIMENSIONS & WEIGHT			Indoor unit (include panel)	Package Body Panel	
Dimensions	Height	mm (in.)	328 (12 - 29 / 32)	284 (11 - 6 / 32)	104 (4 - 3 / 32)
	Width	mm (in.)	860 (33 - 27 / 32)	824 (32 - 14 / 32)	967 (38 - 2 / 32)
	Depth	mm (in.)	860 (33 - 27 / 32)	833 (32 - 25 / 32)	999 (39 - 11 / 32)
Net weight	kg (lb.)		29 (64)	—	—
Shipping weight	kg (lb.)		—	26 (57)	8 (18)
Shipping volume	m ³ (cu. ft)		—	0.195 (6.9)	0.1 (3.5)

DATA SUBJECT TO CHANGE WITHOUT NOTICE.

Rated conditions

Cooling: Indoor air temperature 27 °C DB / 19 °C WB, Outdoor air temperature 35 °C DB

Heating: Indoor air temperature 20 °C DB, Outdoor air temperature 7 °C DB / 6 °C WB

SM830063

2. 4-Way Air Discharge Semi-concealed Type

Unit specifications (C)

MODEL No.		Indoor Unit		SPW-XR253GH56		
POWER SOURCE				220 - 230 - 240 V / 1 phase / 50Hz		
PERFORMANCE				Cooling		Heating
Capacity		kW BTU / h	7.3 25,000	8.0 27,000		
Air circulation (Hi / Me / Lo)		m ³ /h	1,140 / 1,020 / 840			
Moisture removal (High)		Liters/h	3.6	—		
ELECTRICAL RATINGS						
Voltage rating		V	220 - 230 - 240			
Available voltage range		V	198 - 264			
Running amperes		A	0.60 - 0.62 - 0.63	0.37 - 0.40 - 0.42		
Power input		W	130 - 140 - 150	80 - 90 - 100		
Power factor		%	98 - 98 - 99	98 - 98 - 99		
Fan motor locked rotor amperes		A	1 - 1 - 1			
FEATURES						
Controls		Microprocessor				
Timer		ON / OFF Timer (Max. 72 hr)				
Fan speeds		3 and Automatic control				
Air filter		Washable, easy access, long life (2,500 hr)				
Refrigerant control		Electronic expansion valve				
Operation sound (Hi / Me / Lo)		dB-A	37 / 35 / 31			
Refrigerant tubing connections		Flare type				
Refrigerant tube diameter	Narrow tube mm (in.)	9.52 (3 / 8)*				
	Wide tube mm (in.)	15.88 (5 / 8)				
Drain connection		25 A, OD32 mm				
Drain pump		Max. head 25 cm above drain connection				
Panel		Optional (PNR-X253GHA)				
Remote Controller		Optional (RCS-SH80TG)				
Refrigerant tubing kit / Accessories		Optional / —				
Color (Approximate value)		Munsell 10Y9.3 / 0.4, RAL 9010-GL				
DIMENSIONS & WEIGHT			Indoor unit (include panel)	Package		
Dimensions	Height	mm (in.)	328 (12 - 29 / 32)	284 (11 - 6 / 32)	104 (4 - 3 / 32)	
	Width	mm (in.)	860 (33 - 27 / 32)	824 (32 - 14 / 32)	967 (38 - 2 / 32)	
	Depth	mm (in.)	860 (33 - 27 / 32)	833 (32 - 25 / 32)	999 (39 - 11 / 32)	
Net weight		kg (lb.)	30 (66)	—	—	
Shipping weight		kg (lb.)	—	27 (60)	8 (18)	
Shipping volume		m ³ (cu. ft)	—	0.195 (6.9)	0.1 (3.5)	

DATA SUBJECT TO CHANGE WITHOUT NOTICE.

Rated conditions

Cooling: Indoor air temperature 27 °C DB / 19 °C WB, Outdoor air temperature 35 °C DB

Heating: Indoor air temperature 20 °C DB, Outdoor air temperature 7 °C DB / 6 °C WB

* Use the "Tube connector" (accessory part with unit).

SM830063

2. 4-Way Air Discharge Semi-concealed Type

Unit specifications (D)

MODEL No.	Indoor Unit		SPW-XR363GH56		
POWER SOURCE			220 - 230 - 240 V / 1 phase / 50Hz		
PERFORMANCE			Cooling		Heating
Capacity	kW		10.6		11.4
	BTU / h		36,000		39,000
Air circulation (Hi / Me / Lo)		m ³ /h	1,920 / 1,680 / 1,320		
Moisture removal (High)		Liters/h	4.6	—	
ELECTRICAL RATINGS					
Voltage rating		V	220 - 230 - 240		
Available voltage range		V	198 - 264		
Running amperes		A	0.92 - 0.92 - 0.93	0.65 - 0.67 - 0.68	
Power input		W	200 - 210 - 220	140 - 150 - 160	
Power factor		%	99 - 99 - 99	98 - 97 - 98	
Fan motor locked rotor amperes		A	2 - 2 - 2		
FEATURES					
Controls			Microprocessor		
Timer			ON / OFF Timer (Max. 72 hr)		
Fan speeds			3 and Automatic control		
Air filter			Washable, easy access, long life (2,500 hr)		
Refrigerant control			Electronic expansion valve		
Operation sound (Hi / Me / Lo)		dB-A	43 / 40 / 36		
Refrigerant tubing connections			Flare type		
Refrigerant tube diameter		Narrow tube mm (in.)	9.52 (3 / 8)		
		Wide tube mm (in.)	19.05 (3 / 4)		
Drain connection			25 A, OD32 mm		
Drain pump			Max. head 25 cm above drain connection		
Panel			Optional (PNR-X483GHA)		
Remote Controller			Optional (RCS-SH80TG)		
Refrigerant tubing kit / Accessories			Optional / —		
Color (Approximate value)			Munsell 10Y9.3 / 0.4, RAL 9010-GL		
DIMENSIONS & WEIGHT			Indoor unit (include panel)	Package	
				Body	Panel
Dimensions	Height	mm (in.)	358 (14 - 3 / 32)	316 (12 - 14 / 32)	104 (4 - 3 / 32)
	Width	mm (in.)	1150 (45 - 9 / 32)	1114 (43 - 27 / 32)	1257 (49 - 16 / 32)
	Depth	mm (in.)	860 (33 - 27 / 32)	833 (32 - 25 / 32)	999 (39 - 11 / 32)
Net weight		kg (lb.)	38 (84)	—	—
Shipping weight		kg (lb.)	—	32 (71)	10 (22)
Shipping volume		m ³ (cu. ft)	—	0.293 (10.3)	0.131 (4.6)

DATA SUBJECT TO CHANGE WITHOUT NOTICE.

Rated conditions

Cooling: Indoor air temperature 27 °C DB / 19 °C WB, Outdoor air temperature 35 °C DB

Heating: Indoor air temperature 20 °C DB , Outdoor air temperature 7 °C DB / 6 °C WB

SM830063

2. 4-Way Air Discharge Semi-concealed Type

Unit specifications (E)

MODEL No.		Indoor Unit		SPW-XR483GH56		
POWER SOURCE				220 - 230 - 240 V / 1 phase / 50Hz		
PERFORMANCE				Cooling		Heating
Capacity		kW BTU / h	14.0 47,800	16.0 54,600		
Air circulation (Hi / Me / Lo)		m ³ /h	1,920 / 1,680 / 1,320			
Moisture removal (High)		Liters/h	7.4	—		
ELECTRICAL RATINGS						
Voltage rating		V	220 - 230 - 240			
Available voltage range		V	198 - 264			
Running amperes		A	0.92 - 0.92 - 0.93	0.65 - 0.67 - 0.68		
Power input		W	200 - 210 - 220	140 - 150 - 160		
Power factor		%	99 - 99 - 99	98 - 97 - 98		
Fan motor locked rotor amperes		A	2 - 2 - 2			
FEATURES						
Controls		Microprocessor				
Timer		ON / OFF Timer (Max. 72 hr)				
Fan speeds		3 and Automatic control				
Air filter		Washable, easy access, long life (2,500 hr)				
Refrigerant control		Electronic expansion valve				
Operation sound (Hi / Me / Lo)		dB-A	43 / 40 / 36			
Refrigerant tubing connections		Flare type				
Refrigerant tube diameter	Narrow tube mm (in.)	9.52 (3 / 8)				
	Wide tube mm (in.)	19.05 (3 / 4)				
Drain connection		25 A, OD32 mm				
Drain pump		Max. head 25 cm above drain connection				
Panel		Optional (PNR-X483GHA)				
Remote Controller		Optional (RCS-SH80TG)				
Refrigerant tubing kit / Accessories		Optional / —				
Color (Approximate value)		Munsell 10Y9.3 / 0.4, RAL 9010-GL				
DIMENSIONS & WEIGHT			Indoor unit (include panel)	Package		
Dimensions	Height	mm (in.)	358 (14 - 3 / 32)	316 (12 - 14 / 32)	104 (4 - 3 / 32)	
	Width	mm (in.)	1150 (45 - 9 / 32)	1114 (43 - 27 / 32)	1257 (49 - 16 / 32)	
	Depth	mm (in.)	860 (33 - 27 / 32)	833 (32 - 25 / 32)	999 (39 - 11 / 32)	
Net weight		kg (lb.)	38 (84)	—	—	
Shipping weight		kg (lb.)	—	32 (71)	10 (22)	
Shipping volume		m ³ (cu. ft)	—	0.293 (10.3)	0.131 (4.6)	

DATA SUBJECT TO CHANGE WITHOUT NOTICE.

Rated conditions

Cooling: Indoor air temperature 27 °C DB / 19 °C WB, Outdoor air temperature 35 °C DB

Heating: Indoor air temperature 20 °C DB, Outdoor air temperature 7 °C DB / 6 °C WB

SM830063

2. 4-Way Air Discharge Semi-concealed Type

2-2. Major component specifications

Indoor unit (A)

MODEL No.		SPW-XR123GH56	
Source		220 - 230 - 240 V / 1 phase / 50Hz	
Controller P.C.B. Ass'y		CR-X253GH (Microprocessor)	
Fan (Number...diameter)	mm	Turbo (1 ... ø 490)	
Fan motor			
Model...Nominal output	W	SFG6X-41A5P ... 40 W	
Source		220 - 230 - 240 V / 1 phase / 50 Hz	
No. of pole...r.p.m. (230 V, High)	rpm.	6 ... 442	
Coil resistance (Ambient temperature 20°C)	Ω	BRN – WHT : 114.0 WHT – VLT : 23.9 VLT – ORG : 12.4	ORG – YEL : 66.4 WHT – PNK : 77.4 YEL – BLK : 82.1
Safety device			
Operating temperature	Open °C	130 ± 8	
	Close °C	(79 ± 15)	
Run capacitor	VAC, μF	440 V , 3.5 μF	
Electronic expansion valve			
Coil		DKV-MOZS582E0	
Coil resistance (at 20°C)	Ω	ORG – GRY : 46 , YEL – GRY : 46 RED – GRY : 46 , BLK – GRY : 46	
Valve body		IKV-24D12	
Heat exchanger			
Coil		Aluminum plate fin / Copper tube	
Rows...fin pitch	mm	2...1.5	
Face area	m ²	0.295	
Panel			
Model No.		PNR-X253GHA	
Dew proof heater		240 V, 26 W	
Auto louver motor		M2LB24ZA12	
Auto louver motor...Rated	V, W, rpm.	240 VAC, 3W, 2.5 rpm	
Coil resistance (at 25 °C)	Ω	15.620 Ω ± 15 %	
Drain Pump			
Rated		V, W	
Total head & capacity		AC230 V, 50 Hz, 14.7 W 400 mm, 600 cc/min	

1

2. 4-Way Air Discharge Semi-concealed Type

Indoor unit (B)

MODEL No.		SPW-XR183GH56	
Source		220 - 230 - 240 V / 1 phase / 50Hz	
Controller P.C.B. Ass'y		CR-X253GH (Microprocessor)	
Fan (Number...diameter)	mm	Turbo (1 ... ø 490)	
Fan motor			
Model...Nominal output	W	SFG6X-41A5P ... 40 W	
Source		220 - 230 - 240 V / 1 phase / 50 Hz	
No. of pole...r.p.m. (230 V, High)	rpm.	6 ... 442	
Coil resistance (Ambient temperature 20°C)	Ω	BRN – WHT : 114.0	ORG – YEL : 66.4
		WHT – VLT : 23.9	WHT – PNK : 77.4
		VLT – ORG : 12.4	YEL – BLK : 82.1
Safety device			
Operating temperature	Open °C	130 ± 8	
	Close °C	(79 ± 15)	
Run capacitor	VAC, μF	440 V , 3.5 μF	
Electronic expansion valve			
Coil		DKV-MOZS582E0	
Coil resistance (at 20°C)	Ω	ORG – GRY : 46 ,	YEL – GRY : 46
		RED – GRY : 46 ,	BLK – GRY : 46
Valve body		IKV-24D12	
Heat exchanger			
Coil		Aluminum plate fin / Copper tube	
Rows...fin pitch	mm	2...1.5	
Face area	m ²	0.295	
Panel			
Model No.		PNR-X253GHA	
Dew proof heater		240 V, 26 W	
Auto louver motor		M2LB24ZA12	
Auto louver motor...Rated	V, W, rpm.	240 VAC, 3W, 2.5 rpm	
Coil resistance (at 25 °C)	Ω	15.620 Ω ± 15 %	
Drain Pump		WP20SL - 21	
Rated	V, W	AC230 V, 50 Hz, 14.7 W	
Total head & capacity		400 mm, 600 cc/min	

2. 4-Way Air Discharge Semi-concealed Type

Indoor unit (C)

MODEL No.		SPW-XR253GH56	
Source		220 - 230 - 240 V / 1 phase / 50Hz	
Controller P.C.B. Ass'y		CR-X253GH (Microprocessor)	
Fan (Number...diameter)	mm	Turbo (1 ... ø 490)	
Fan motor			
Model...Nominal output	W	SFG6X-41A5P ... 40 W	
Source		220 - 230 - 240 V / 1 phase / 50 Hz	
No. of pole...r.p.m. (230 V, High)	rpm.	6 ... 461	
Coil resistance (Ambient temperature 20°C)	Ω	BRN – WHT : 114.0 WHT – VLT : 23.9 VLT – ORG : 12.4	ORG – YEL : 66.4 WHT – PNK : 77.4 YEL – BLK : 82.1
Safety device			
Operating temperature	Open °C	130 ± 8	
	Close °C	(79 ± 15)	
Run capacitor	VAC, μF	440 V , 4 μF	
Electronic expansion valve			
Coil		DKV-MOZS582E0	
Coil resistance (at 20°C)	Ω	ORG – GRY : 46, RED – GRY : 46,	YEL – GRY : 46 BLK – GRY : 46
Valve body		IKV-24D12	
Heat exchanger			
Coil		Aluminum plate fin / Copper tube	
Rows...fin pitch	mm	2 ... 1.5	
Face area	m ²	0.295	
Panel			
Model No.		PNR-X253GHA	
Dew proof heater		240 V, 26 W	
Auto louver motor		M2LB24ZA12	
Auto louver motor...Rated	V, W, rpm.	240 VAC, 3W, 2.5 rpm	
Coil resistance (at 25 °C)	Ω	15.620 Ω ± 15 %	
Drain Pump		WP20SL - 21	
Rated	V, W	AC230 V, 50 Hz, 14.7 W	
Total head & capacity		400 mm, 600 cc/min	

1

2. 4-Way Air Discharge Semi-concealed Type

Indoor unit (D)

MODEL No.		SPW-XR363GH56	
Source		220 - 230 - 240 V / 1 phase / 50Hz	
Controller P.C.B. Ass'y		CR-X253GH (Microprocessor)	
Fan (Number...diameter)	mm	Turbo (1 ... ø 490)	
Fan motor			
Model...Nominal output	W	SFG6X-61A3P...60 W	
Source		220 - 230 - 240 V / 1 phase / 50 Hz	
No. of pole...r.p.m. (230 V, High)	rpm.	6 ... 530	
Coil resistance (Ambient temperature 20°C)	Ω	BRN – WHT : 71.1 ORG – YEL : 22.7 WHT – VLT : 8.7 VLT – PNK : 43.2 VLT – ORG : 13.3 YEL – BLK : 54.32	
Safety device			
Operating temperature	Open °C	130 ± 8	
	Close °C	(79 ± 15)	
Run capacitor	VAC, μF	440 V , 6 μF	
Electronic expansion valve			
Coil		EKV-MOZS584E0	
Coil resistance (at 20°C)	Ω	ORG – GRY : 46 , YEL – GRY : 46 RED – GRY : 46 , BLK – GRY : 46	
Valve body		HKV-30D16	
Heat exchanger			
Coil		Aluminum plate fin / Copper tube	
Rows...fin pitch	mm	2...1.5	
Face area	m ²	0.479	
Panel			
Model No.		PNR-X483GHA	
Dew proof heater		240 V, 31 W	
Auto louver motor		M2LB24ZA12	
Auto louver motor...Rated	V, W, rpm.	240 VAC, 3W, 2.5 rpm	
Coil resistance (at 25 °C)	Ω	15.620 Ω ± 15 %	
Drain Pump		WP20SL - 21	
Rated	V, W	AC230 V, 50 Hz, 14.7 W	
Total head & capacity		400 mm, 600 cc/min	

2. 4-Way Air Discharge Semi-concealed Type

Indoor unit (E)

MODEL No.		SPW-XR483GH56	
Source		220 - 230 - 240 V / 1 phase / 50Hz	
Controller P.C.B. Ass'y		CR-X253GH (Microprocessor)	
Fan (Number...diameter)	mm	Turbo (1 ... ø 490)	
Fan motor			
Model...Nominal output	W	SFG6X-61A3P...60 W	
Source		220 - 230 - 240 V / 1 phase / 50 Hz	
No. of pole...r.p.m. (230 V, High)	rpm.	6 ... 530	
Coil resistance (Ambient temperature 20°C)	Ω	BRN – WHT : 71.1	ORG – YEL : 22.7
		WHT – VLT : 8.7	VLT – PNK : 43.2
		VLT – ORG : 13.3	YEL – BLK : 54.32
Safety device			
Operating temperature	Open °C	130 ± 8	
	Close °C	(79 ± 15)	
Run capacitor	VAC, μF	440 V , 6 μF	
Electronic expansion valve			
Coil		EKV-MOZS584E0	
Coil resistance (at 20°C)	Ω	ORG – GRY : 46 ,	YEL – GRY : 46
		RED – GRY : 46 ,	BLK – GRY : 46
Valve body		HKV-30D16	
Heat exchanger			
Coil		Aluminum plate fin / Copper tube	
Rows...fin pitch	mm	2...1.5	
Face area	m ²	0.479	
Panel			
Model No.		PNR-X483GHA	
Dew proof heater		240 V, 31 W	
Auto louver motor		M2LB24ZA12	
Auto louver motor...Rated	V, W, rpm.	240 VAC, 3W, 2.5 rpm	
Coil resistance (at 25 °C)	Ω	15.620 Ω ± 15 %	
Drain Pump		WP20SL - 21	
Rated	V, W	AC230 V, 50 Hz, 14.7 W	
Total head & capacity		400 mm, 600 cc/min	

1

2. 4-Way Air Discharge Semi-concealed Type

2-3. Other component specifications

MODEL NO.	Indoor Unit	SPW-XR123 ~ 483GH56
Power Transformer		ATR-II215TA
Rated		
Primary	V, Hz	AC 230 V, 50 Hz
Secondary		10.2 V 1.4 A
		14 V 0.5 A
Coil resistance	Ω	WHT – WHT : 84 , BRN – BRN : 0.7 RED – RED : 2.7
Thermal cut off temperature	$^{\circ}\text{C}$	150
Thermistor (Coil sensor)		PB3M-41E-S4 , PBC-41E-S25 , PBC-41E-S26 , PBC-41E-S36
Resistance	K Ω	-10 $^{\circ}\text{C}$: 23.7 \pm 5 % , 20 $^{\circ}\text{C}$: 6.5 \pm 5 % -5 $^{\circ}\text{C}$: 18.8 \pm 5 % , 30 $^{\circ}\text{C}$: 4.4 \pm 5 % 0 $^{\circ}\text{C}$: 15.0 \pm 5 % , 40 $^{\circ}\text{C}$: 3.1 \pm 5 % 5 $^{\circ}\text{C}$: 12.1 \pm 5 % , 45 $^{\circ}\text{C}$: 2.6 \pm 5 % 10 $^{\circ}\text{C}$: 9.7 \pm 5 %
Thermistor (Room or coil sensor)		KTEC-35-S6
Resistance	K Ω	0 $^{\circ}\text{C}$: 16.5 \pm 5 % , 40 $^{\circ}\text{C}$: 2.7 \pm 5 % 5 $^{\circ}\text{C}$: 12.8 \pm 5 % , 45 $^{\circ}\text{C}$: 2.2 \pm 5 % 10 $^{\circ}\text{C}$: 10.0 \pm 5 % , 50 $^{\circ}\text{C}$: 1.8 \pm 5 % 20 $^{\circ}\text{C}$: 6.3 \pm 5 % , 55 $^{\circ}\text{C}$: 1.5 \pm 5 % 30 $^{\circ}\text{C}$: 4.0 \pm 5 %
Electronic expansion valve		
Valve body		IKV-24D12 (SPW-XR123 ~ 253GH56) HKV-30D16 (SPW-XR363 · 483GH56)
Coil		DKV-MOZS582E0 (SPW-XR123 ~ 253GH56) EKV-MOZS584E0 (SPW-XR363 · 483GH56)
Drain pump		WP20SL-21
Rated		AC 230 V, 14.7 W
Float switch		FS-0218-102 (SPW-XR123 ~ 253GH56) FS-0218-103 (SPW-XR363 · 483GH56)
Rated (Contact rated)		DC 12 V, 25 W

2. 4-Way Air Discharge Semi-concealed Type

2-4. Dimensional data

Indoor unit : 12, 18, 25 Type

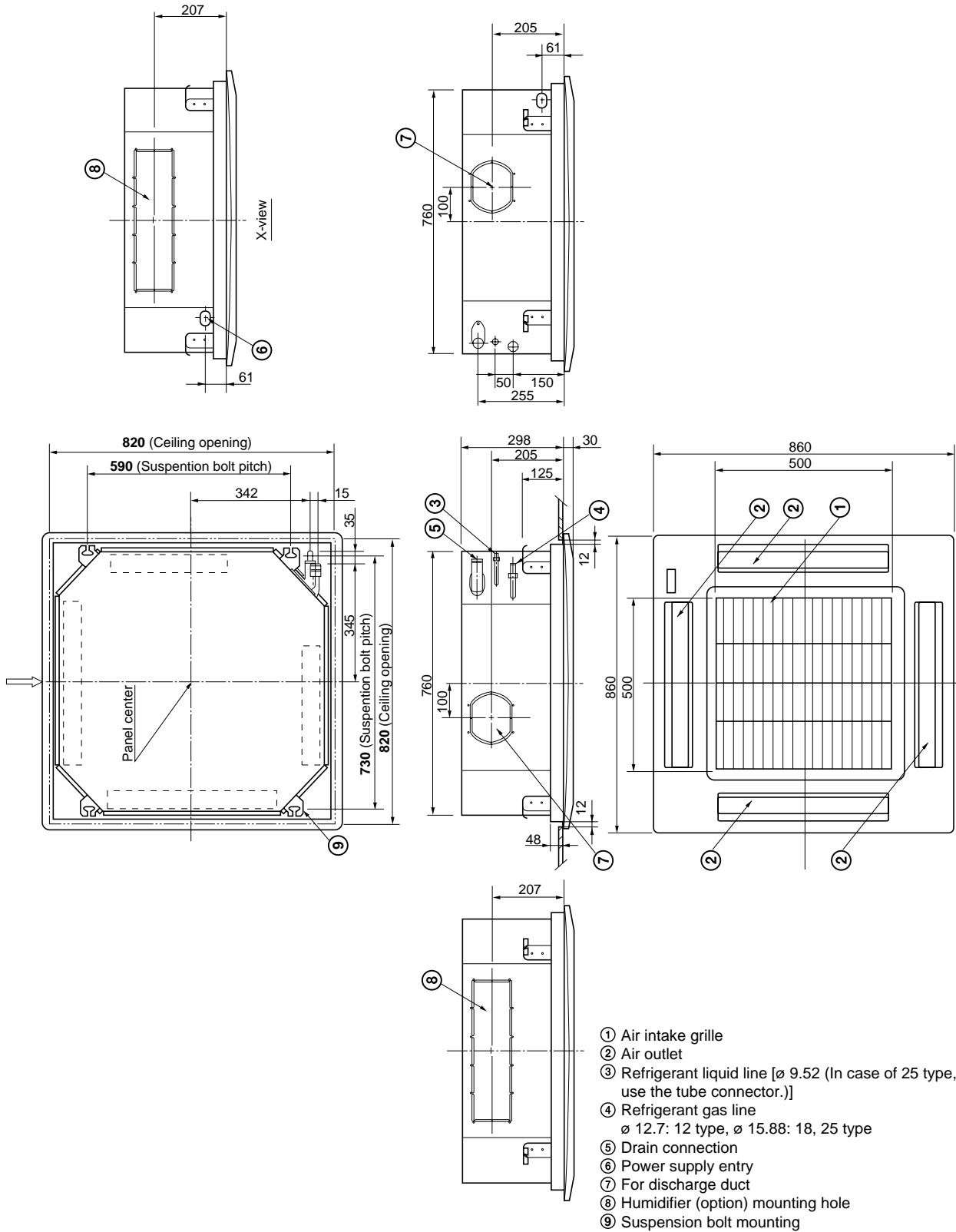

0182_X_1

2. 4-Way Air Discharge Semi-concealed Type

Indoor unit : 36, 48 Type

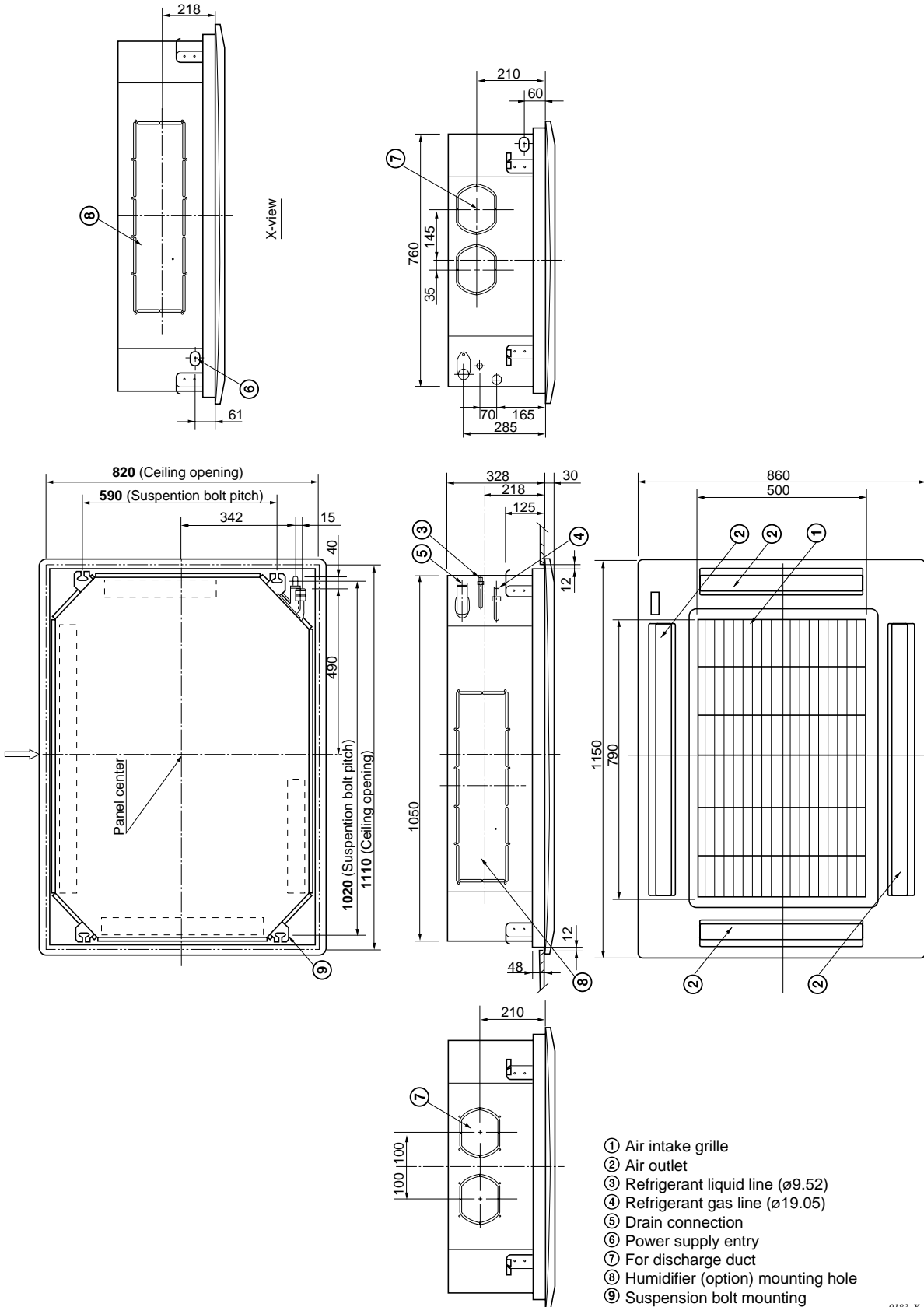

0183_X_I

SM830063

2. 4-Way Air Discharge Semi-concealed Type

2-5. Noise criterion curves

MODEL	: SPW-XR123GH56 , XR183GH56
SOUND LEVEL	: HIGH 37 dB(A), NC 30 LOW 30 dB(A), NC 22
CONDITION	: Center, Under the unit 1.5 m
SOURCE	: 220 - 230 - 240 V, 1 Phase, 50 Hz

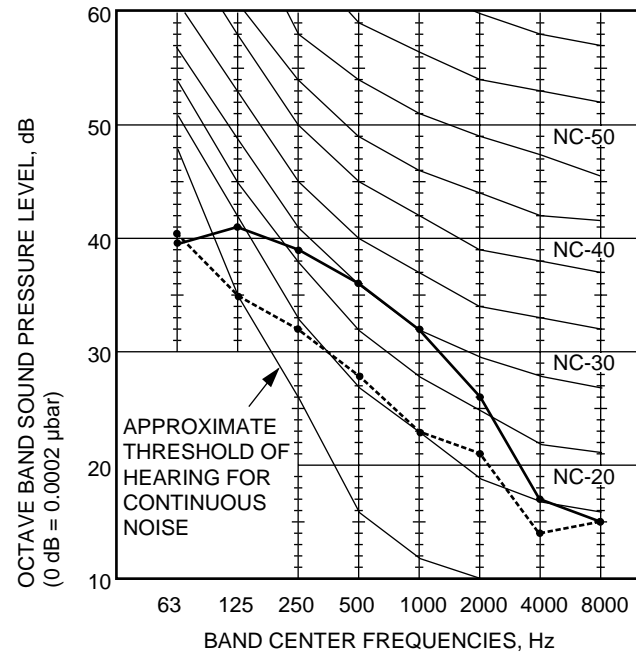

MODEL	: SPW-XR253GH56
SOUND LEVEL	: HIGH 37 dB(A), NC 30 LOW 31 dB(A), NC 22
CONDITION	: Center, Under the unit 1.5 m
SOURCE	: 220 - 230 - 240 V, 1 Phase, 50 Hz

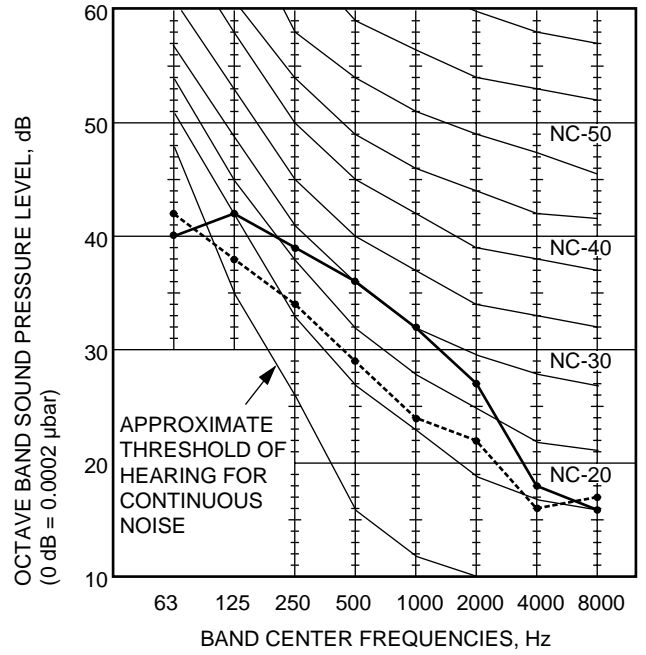

MODEL	: SPW-XR363GH56 , XR483GH56
SOUND LEVEL	: HIGH 43 dB(A), NC 36 LOW 36 dB(A), NC 24
CONDITION	: Center, Under the unit 1.5 m
SOURCE	: 220 - 230 - 240 V, 1 Phase, 50 Hz

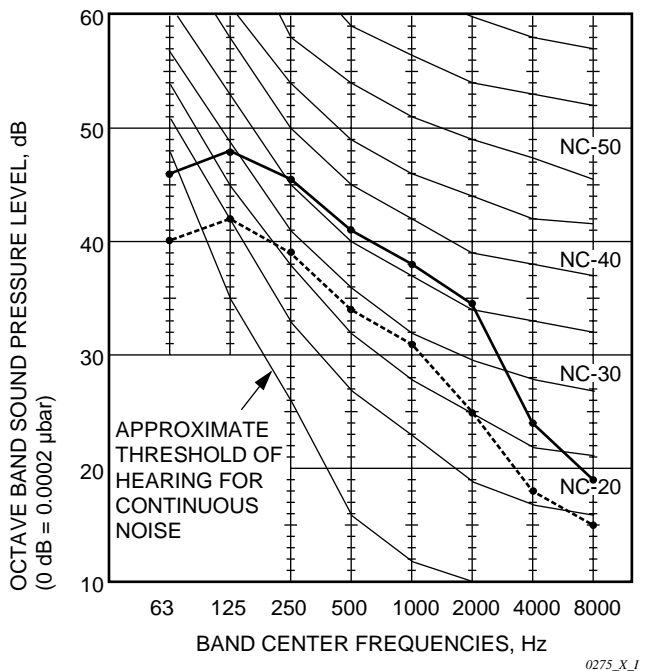

- REMARKS:**
1. Value obtained in the actual place where the unit is installed may be slightly higher than the values shown in this graph because of the conditions of operation, the structure of the building, the background noise and other factors.
 2. The test results were obtained from an anechoic room.

NOTE To evaluate "Noise level" the maximum number of the measured OCTAVE BAND SOUND PRESSURE LEVEL is used. Read the number on each BAND CENTER FREQUENCIES (horizontal axis) ranging from 63 Hz to 8000 Hz and select the maximum value (vertical axis) among them.



2. 4-Way Air Discharge Semi-concealed Type

2-6. Air throw distance chart

Model: 12, 18, 25 Type

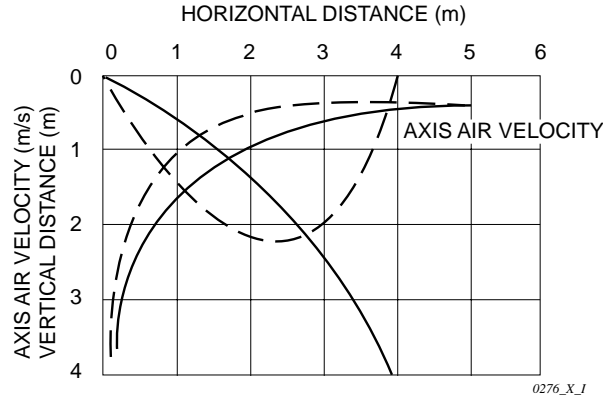

Model: 36, 48 Type

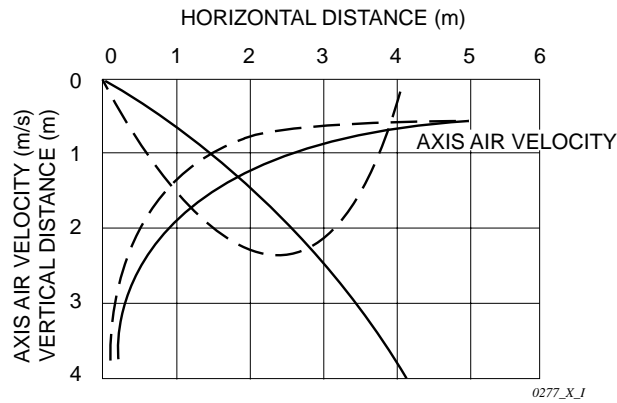

————— : LOUVER ANGLE 20° in Cooling mode
 - - - - - : LOUVER ANGLE 60° in Heating mode

Condition Fan Speed : Hi

Room air temp. : 27 °C DB in cooling mode

20 °C DB in heating mode

3. 2-Way Air Discharge Semi-concealed Type

3-1. Specifications

Unit specifications (A)

MODEL No.	Indoor Unit		SPW-SR93GH56	
POWER SOURCE	220 - 230 - 240 V / 1 phase / 50Hz			
PERFORMANCE			Cooling	Heating
Capacity	kW BTU / h		2.8 9,600	3.2 11,000
Air circulation (Hi / Me / Lo)	m ³ /h		540 / 485 / 410	
Moisture removal (High)	Liters/h		1.0	—
ELECTRICAL RATINGS				
Voltage rating	V		220 - 230 - 240	
Available voltage range	V		198 - 264	
Running amperes	A		0.33 - 0.34 - 0.35	0.24 - 0.25 - 0.26
Power input	W		70 - 75 - 80	50 - 55 - 60
Power factor	%		96 - 96 - 95	95 - 96 - 96
Fan motor locked rotor amperes	A		1 - 1 - 1	
FEATURES				
Controls	Microprocessor			
Timer	ON / OFF Timer (Max. 72 hr)			
Fan speeds	3 and Automatic control			
Air filter	Washable, easy access, long life (2,500 hr)			
Refrigerant control	Electronic expansion valve			
Operation sound (Hi / Me / Lo)	dB-A		32 / 30 / 25	
Refrigerant tubing connections	Flare type			
Refrigerant tube diameter	Narrow tube mm (in.)		9.52 (3 / 8)	
	Wide tube mm (in.)		12.7 (1 / 2)	
Drain connection	25 A, OD32 mm			
Drain pump	Max. head 25 cm above drain connection			
Remote Controller	Optional (RCS-SH80TG)			
Refrigerant tubing kit / Accessories	Optional / —			
Color (Approximate value)	Munsell 10Y9.3 / 0.4, RAL 9010-GL			
DIMENSIONS & WEIGHT (include ceiling panel)				
Dimensions	Height	mm (in.)	398 (15 - 5 / 8)	519 (20 - 3 / 8)
	Width	mm (in.)	1,110 (43 - 3 / 4)	1,218 (48)
	Depth	mm (in.)	680 (26 - 3 / 4)	788 (31)
Net weight	kg (lbs.)		40 (88)	
Shipping weight	kg (lbs.)		61 (135)	
Shipping volume	m ³ (cu. ft)		0.498 (17.6)	

DATA SUBJECT TO CHANGE WITHOUT NOTICE.

Rated conditions

Cooling: Indoor air temperature 27 °C DB / 19 °C WB, Outdoor air temperature 35 °C DB

Heating: Indoor air temperature 20 °C DB , Outdoor air temperature 7 °C DB / 6 °C WB

3. 2-Way Air Discharge Semi-concealed Type

Unit specifications (B)

MODEL No.	Indoor Unit		SPW-SR123GH56	
POWER SOURCE			220 - 230 - 240 V / 1 phase / 50Hz	
PERFORMANCE			Cooling	Heating
Capacity	kW		3.6	4.2
	BTU / h		12,000	14,000
Air circulation (Hi / Me / Lo)		m ³ /h	570 / 510 / 430	
Moisture removal (High)		Liters/h	1.6	—
ELECTRICAL RATINGS				
Voltage rating		V	220 - 230 - 240	
Available voltage range		V	198 - 264	
Running amperes		A	0.36 - 0.37 - 0.38	0.27 - 0.28 - 0.29
Power input		W	75 - 80 - 85	55 - 60 - 65
Power factor		%	95 - 94 - 93	93 - 93 - 93
Fan motor locked rotor amperes		A	1 - 1 - 1	
FEATURES				
Controls			Microprocessor	
Timer			ON / OFF Timer (Max. 72 hr)	
Fan speeds			3 and Automatic control	
Air filter			Washable, easy access, long life (2,500 hr)	
Refrigerant control			Electronic expansion valve	
Operation sound (Hi / Me / Lo)		dB-A	33 / 30 / 26	
Refrigerant tubing connections			Flare type	
Refrigerant tube diameter	Narrow tube mm (in.)		9.52 (3 / 8)	
	Wide tube mm (in.)		12.7 (1 / 2)	
Drain connection			25 A, OD32 mm	
Drain pump			Max. head 25 cm above drain connection	
Remote Controller			Optional (RCS-SH80TG)	
Refrigerant tubing kit / Accessories			Optional / —	
Color (Approximate value)			Munsell 10Y9.3 / 0.4, RAL 9010-GL	
DIMENSIONS & WEIGHT (include ceiling panel)			Unit dimensions	Package dimensions
Dimensions	Height	mm (in.)	398 (15 - 5 / 8)	519 (20 - 3 / 8)
	Width	mm (in.)	1,110 (43 - 3 / 4)	1,218 (48)
	Depth	mm (in.)	680 (26 - 3 / 4)	788 (31)
Net weight		kg (lbs.)	40 (88)	
Shipping weight		kg (lbs.)	61 (135)	
Shipping volume		m ³ (cu. ft)	0.498 (17.6)	

DATA SUBJECT TO CHANGE WITHOUT NOTICE.

Rated conditions

Cooling: Indoor air temperature 27 °C DB / 19 °C WB, Outdoor air temperature 35 °C DB

Heating: Indoor air temperature 20 °C DB , Outdoor air temperature 7 °C DB / 6 °C WB

3. 2-Way Air Discharge Semi-concealed Type

Unit specifications (C)

MODEL No.	Indoor Unit		SPW-SR183GH56	
POWER SOURCE	220 - 230 - 240 V / 1 phase / 50Hz			
PERFORMANCE			Cooling	Heating
Capacity	kW		5.6	6.3
	BTU / h		19,000	21,000
Air circulation (Hi / Me / Lo)	m ³ /h		960 / 860 / 720	
Moisture removal (High)	Liters/h		2.4	—
ELECTRICAL RATINGS				
Voltage rating	V		220 / 230 / 240	
Available voltage range	V		198 – 264	
Running amperes	A		0.60 - 0.61 - 0.62	0.50 - 0.51 - 0.53
Power input	W		129 - 137 - 146	105 - 113 - 122
Power factor	%		98 - 98 - 98	95 - 96 - 96
Fan motor locked rotor amperes	A		1 - 1 - 1	
FEATURES				
Controls	Microprocessor			
Timer	ON / OFF Timer (Max. 72 hr)			
Fan speeds	3 and Automatic control			
Air filter	Washable, easy access, long life (2,500 hr)			
Refrigerant control	Electronic expansion valve			
Operation sound (Hi / Me / Lo)	dB-A		34 / 31 / 27	
Refrigerant tubing connections	Flare type			
Refrigerant tube diameter	Narrow tube mm (in.)		9.52 (3 / 8)	
	Wide tube mm (in.)		15.88 (5 / 8)	
Drain connection	25 A, OD32 mm			
Drain pump	Max. head 25 cm above drain connection			
Remote Controller	Optional (RCS-SH80TG)			
Refrigerant tubing kit / Accessories	Optional / —			
Color (Approximate value)	Munsell 10Y9.3 / 0.4, RAL 9010-GL			
DIMENSIONS & WEIGHT (include ceiling panel)				
Dimensions	Height	mm (in.)	398 (15 - 5 / 8)	519 (20 - 3 / 8)
	Width	mm (in.)	1,390 (54 - 3 / 4)	1,498 (59)
	Depth	mm (in.)	680 (26 - 3 / 4)	788 (31)
Net weight	kg (lbs.)		50 (110)	
Shipping weight	kg (lbs.)		76 (168)	
Shipping volume	m ³ (cu. ft)		0.613 (21.6)	

DATA SUBJECT TO CHANGE WITHOUT NOTICE.

Rated conditions

Cooling: Indoor air temperature 27 °C DB / 19 °C WB, Outdoor air temperature 35 °C DB

Heating: Indoor air temperature 20 °C DB , Outdoor air temperature 7 °C DB / 6 °C WB

3. 2-Way Air Discharge Semi-concealed Type

Unit specifications (D)

MODEL No.	Indoor Unit		SPW-SR253GH56	
POWER SOURCE			220 - 230 - 240 V / 1 phase / 50Hz	
PERFORMANCE			Cooling	Heating
Capacity	kW		7.3	8.0
	BTU / h		25,000	27,000
Air circulation (Hi / Me / Lo)		m ³ /h	1,140 / 1,030 / 860	
Moisture removal (High)		Liters/h	3.5	—
ELECTRICAL RATINGS				
Voltage rating		V	220 - 230 - 240	
Available voltage range		V	198 - 264	
Running amperes		A	0.65 - 0.66 - 0.67	0.55 - 0.56 - 0.57
Power input		W	141 - 150 - 158	117 - 126 - 134
Power factor		%	99 - 99 - 98	97 - 98 - 98
Fan motor locked rotor amperes		A	1 - 1 - 1	
FEATURES				
Controls			Microprocessor	
Timer			ON / OFF Timer (Max. 72 hr)	
Fan speeds			3 and Automatic control	
Air filter			Washable, easy access, long life (2,500 hr)	
Refrigerant control			Electronic expansion valve	
Operation sound (Hi / Me / Lo)		dB-A	37 / 35 / 30	
Refrigerant tubing connections			Flare type	
Refrigerant tube diameter	Narrow tube mm (in.)		9.52 (3 / 8)*	
	Wide tube mm (in.)		15.88 (5 / 8)	
Drain connection			25 A, OD32 mm	
Drain pump			Max. head 25 cm above drain connection	
Remote Controller			Optional (RCS-SH80TG)	
Refrigerant tubing kit / Accessories			Optional / Mounting plates	
Color (Approximate value)			Munsell 10Y9.3 / 0.4, RAL 9010-GL	
DIMENSIONS & WEIGHT (include ceiling panel)			Unit dimensions	Package dimensions
Dimensions	Height	mm (in.)	398 (15 - 5 / 8)	519 (20 - 3 / 8)
	Width	mm (in.)	1,390 (54 - 3 / 4)	1,498 (59)
	Depth	mm (in.)	680 (26 - 3 / 4)	788 (31)
Net weight		kg (lbs.)	50 (110)	
Shipping weight		kg (lbs.)	76 (168)	
Shipping volume		m ³ (cu. ft)	0.613 (21.6)	

DATA SUBJECT TO CHANGE WITHOUT NOTICE.

Rated conditions

Cooling: Indoor air temperature 27 °C DB / 19 °C WB, Outdoor air temperature 35 °C DB

Heating: Indoor air temperature 20 °C DB , Outdoor air temperature 7 °C DB / 6 °C WB

* Use the "Tube connector" (accessory part with unit).

3. 2-Way Air Discharge Semi-concealed Type

3-2. Major component specifications

Indoor unit (A)

MODEL No.		SPW-SR93GH56	
Source		220 - 230 - 240 V / 1 phase / 50Hz	
Controller P.C.B. Ass'y		CR-X253GH (Microprocessor)	
Fan (Number...diameter)	mm	Centrifugal (1 ... ø 190)	
Fan motor			
Model...Nominal output	W	UF4X-31B3P ... 30 W	
Source		220 - 230 - 240 V / 1 phase / 50 Hz	
No. of pole...r.p.m. (230 V, High)	rpm.	4P ... 540	
Coil resistance (Ambient temperature 20 °C)	Ω	BRN – WHT : 139.3 WHT – VLT : 19.77 VLT – ORG : 38.20	ORG – YEL : 25.59 YEL – BLK : 43.02 BLK – PNK : 84.32
Safety device			
Operating temperature	Open °C	130 ± 5	
	Close °C	(115 ± 5)	
Run capacitor	VAC, μF	440 V, 1.0 μF	
Electronic expansion valve			
Coil		DKV-MOZS550E0	
Coil resistance (at 20 °C)	Ω	ORG – GRY : 46 , RED – GRY : 46,	YEL – GRY : 46 BLK – GRY : 46
Valve body		IKV-24D12	
Heat exchanger			
Coil		Aluminum plate fin / Copper tube	
Rows...fin pitch	mm	2...1.5	
Face area	m ²	0.265	
Panel			
Model No.		PNR-S123GHA	
Auto louver motor		MT8-3C	
Auto louver motor...Rated	V, W, rpm.	200 ~ 240 VAC, 3 W, 2.5 rpm	
Coil resistance (at 25 °C)	Ω	16.430 Ω ± 8 %	
Drain Pump			
Rated		WP20SL-18	
Rated	V, W	AC230 V, 50 Hz, 14.7 W	
Total head & capacity		400 mm, 600 cc/min	

1

3. 2-Way Air Discharge Semi-concealed Type

Indoor unit (B)

MODEL No.		SPW-SR123GH56	
Source		220 - 230 - 240 V / 1 phase / 50Hz	
Controller P.C.B. Ass'y		CR-X253GH (Microprocessor)	
Fan (Number...diameter)	mm	Centrifugal (1...ø 190)	
Fan motor			
Model...Nominal output	W	UF4X-31B3P ... 30 W	
Source		220 - 230 - 240 V / 1 phase / 50 Hz	
No. of pole...r.p.m. (230 V, High)	rpm.	4P ... 690	
Coil resistance (Ambient temperature 20 °C)	Ω	BRN – WHT : 139.3 WHT – VLT : 19.77 VLT – ORG : 38.20	ORG – YEL : 25.59 YEL – BLK : 43.02 BLK – PNK : 84.32
Safety device			
Operating temperature	Open °C	130 ± 5	
	Close °C	(115 ± 5)	
Run capacitor	VAC, μF	440 V, 1.2 μF	
Electronic expansion valve			
Coil		DKV-MOZS550E0	
Coil resistance (at 20 °C)	Ω	ORG – GRY : 46 , RED – GRY : 46 ,	YEL – GRY : 46 BLK – GRY : 46
Valve body		IKV-24D12	
Heat exchanger			
Coil		Aluminum plate fin / Copper tube	
Rows...fin pitch	mm	2 ... 1.5	
Face area	m ²	0.265	
Panel			
Model No.		PNR-S123GHA	
Auto louver motor		MT8-3C	
Auto louver motor...Rated	V, W, rpm.	200 ~ 240 VAC, 3 W, 2.5 rpm	
Coil resistance (at 25 °C)	Ω	16.430 Ω ± 8 %	
Drain Pump			
Rated		WP20SL-18	
Rated	V, W	AC230 V, 50 Hz, 14.7 W	
Total head & capacity		400 mm, 600 cc/min	

3. 2-Way Air Discharge Semi-concealed Type

Indoor unit (C)

MODEL No.		SPW-SR183GH56	
Source		220 - 230 - 240 V / 1 phase / 50Hz	
Controller P.C.B. Ass'y		CR-X253GH (Microprocessor)	
Fan (Number...diameter)	mm	Centrifugal (2 ... ø190)	
Fan motor			
Model...Nominal output	W	KFG4X-51E3P ... 50 W	
Source		220 - 230 - 240 V / 1 phase / 50 Hz	
No. of pole...r.p.m. (230 V, High)	rpm.	4P ... 568	
Coil resistance (Ambient temperature 20 °C)	Ω	BRN – WHT : 75.52	ORG – YEL : 10.37
		WHT – VLT : 8.39	YEL – BLK : 24.04
		VLT – ORG : 16.31	BLK – PNK : 16.26
Safety device			
Operating temperature	Open °C	130 ± 5	
	Close °C	(115 ± 5)	
Run capacitor	VAC, μF	440 V, 1.5 μF	
Electronic expansion valve			
Coil		DKV-MOZS550E0	
Coil resistance (at 20 °C)	Ω	ORG – GRY : 46 ,	YEL – GRY : 46
		RED – GRY : 46 ,	BLK – GRY : 46
Valve body		IKV-24D12	
Heat exchanger			
Coil		Aluminum plate fin / Copper tube	
Rows...fin pitch	mm	2...1.5	
Face area	m ²	0.382	
Panel			
Model No.		PNR-S253GHA	
Auto louver motor		MT8-3C	
Auto louver motor...Rated	V, W, rpm.	200 ~ 240 VAC, 3 W, 2.5 rpm	
Coil resistance (at 25 °C)	Ω	16.430 Ω ± 8 %	
Drain Pump			
Rated		WP20SL-18	
	V, W	AC230 V, 50 Hz, 14.7 W	
Total head & capacity		400 mm, 600 cc/min	

1

3. 2-Way Air Discharge Semi-concealed Type

Indoor unit (D)

MODEL No.		SPW-SR253GH56	
Source		220 - 230 - 240 V / 1 phase / 50Hz	
Controller P.C.B. Ass'y		CR-X253GH (Microprocessor)	
Fan (Number...diameter)	mm	Centrifugal (2 ... ø 190)	
Fan motor			
Model...Nominal output	W	KFG4X-51E3P ... 50 W	
Source		220 - 230 - 240 V / 1 phase / 50 Hz	
No. of pole...r.p.m. (230 V, High)	rpm.	4P ... 827	
Coil resistance (Ambient temperature 20 °C)	Ω	BRN – WHT : 75.52 ORG – YEL : 10.37 WHT – VLT : 8.39 YEL – BLK : 24.04 VLT – ORG : 16.31 BLK – PNK : 16.26	
Safety device			
Operating temperature	Open °C	130 ± 5	
	Close °C	(115 ± 5)	
Run capacitor	VAC, μF	440 V, 2.5 μF	
Electronic expansion valve			
Coil		DKV-MOZS550E0	
Coil resistance (at 20 °C)	Ω	ORG – GRY : 46 , YEL – GRY : 46 RED – GRY : 46 , BLK – GRY : 46	
Valve body		IKV-24D12	
Heat exchanger			
Coil		Aluminum plate fin / Copper tube	
Rows...fin pitch	mm	2 ... 1.5	
Face area	m ²	0.382	
Panel			
Model No.		PNR-S253GHA	
Auto louver motor		MT8-3C	
Auto louver motor...Rated	V, W, rpm.	200 ~ 240 VAC, 3 W, 2.5 rpm	
Coil resistance (at 25 °C)	Ω	16.430 Ω ± 8 %	
Drain Pump			
Rated		V, W	AC230 V, 50 Hz, 14.7 W
Total head & capacity		400 mm, 600 cc/min	

3. 2-Way Air Discharge Semi-concealed Type

3-3. Other component specifications

MODEL NO.	Indoor Unit	SPW-SR93 ~ 253GH56
Power Transformer		ATR-II215TB
Rated		
Primary	V, Hz	AC 230 V, 50 Hz
Secondary		10.2 V 1.4 A
		14 V 0.5 A
Coil resistance	Ω	WHT –WHT : 112 , BRN – BRN : 0.5 RED – RED : 2.3
Thermal cut off temperature	$^{\circ}\text{C}$	150
Thermistor (Coil sensor)		PBC-41E-S14 , PBC-41E-S25
Resistance	K Ω	-10 $^{\circ}\text{C}$: 23.7 \pm 5 % , 20 $^{\circ}\text{C}$: 6.5 \pm 5 % -5 $^{\circ}\text{C}$: 18.8 \pm 5 % , 30 $^{\circ}\text{C}$: 4.4 \pm 5 % 0 $^{\circ}\text{C}$: 15.0 \pm 5 % , 40 $^{\circ}\text{C}$: 3.1 \pm 5 % 5 $^{\circ}\text{C}$: 12.1 \pm 5 % , 45 $^{\circ}\text{C}$: 2.6 \pm 5 % 10 $^{\circ}\text{C}$: 9.7 \pm 5 %
Thermistor (Room or coil sensor)		KTEC-35-S6
Resistance	K Ω	0 $^{\circ}\text{C}$: 16.5 \pm 5 % , 40 $^{\circ}\text{C}$: 2.7 \pm 5 % 5 $^{\circ}\text{C}$: 12.8 \pm 5 % , 45 $^{\circ}\text{C}$: 2.2 \pm 5 % 10 $^{\circ}\text{C}$: 10.0 \pm 5 % , 50 $^{\circ}\text{C}$: 1.8 \pm 5 % 20 $^{\circ}\text{C}$: 6.3 \pm 5 % , 55 $^{\circ}\text{C}$: 1.5 \pm 5 % 30 $^{\circ}\text{C}$: 4.0 \pm 5 %
Electronic expansion valve		
Valve body		IKV-24D12
Coil		DKV-MOZS550E0
Drain pump		WP20SL-18
Rated		AC 230 V, 14.7 W
Float switch		FS-0218-101
Rated (Contact rated)		DC 12 V, 25 W

1

3. 2-Way Air Discharge Semi-concealed Type

3-4. Dimensional data

Indoor unit : 9, 12 Type

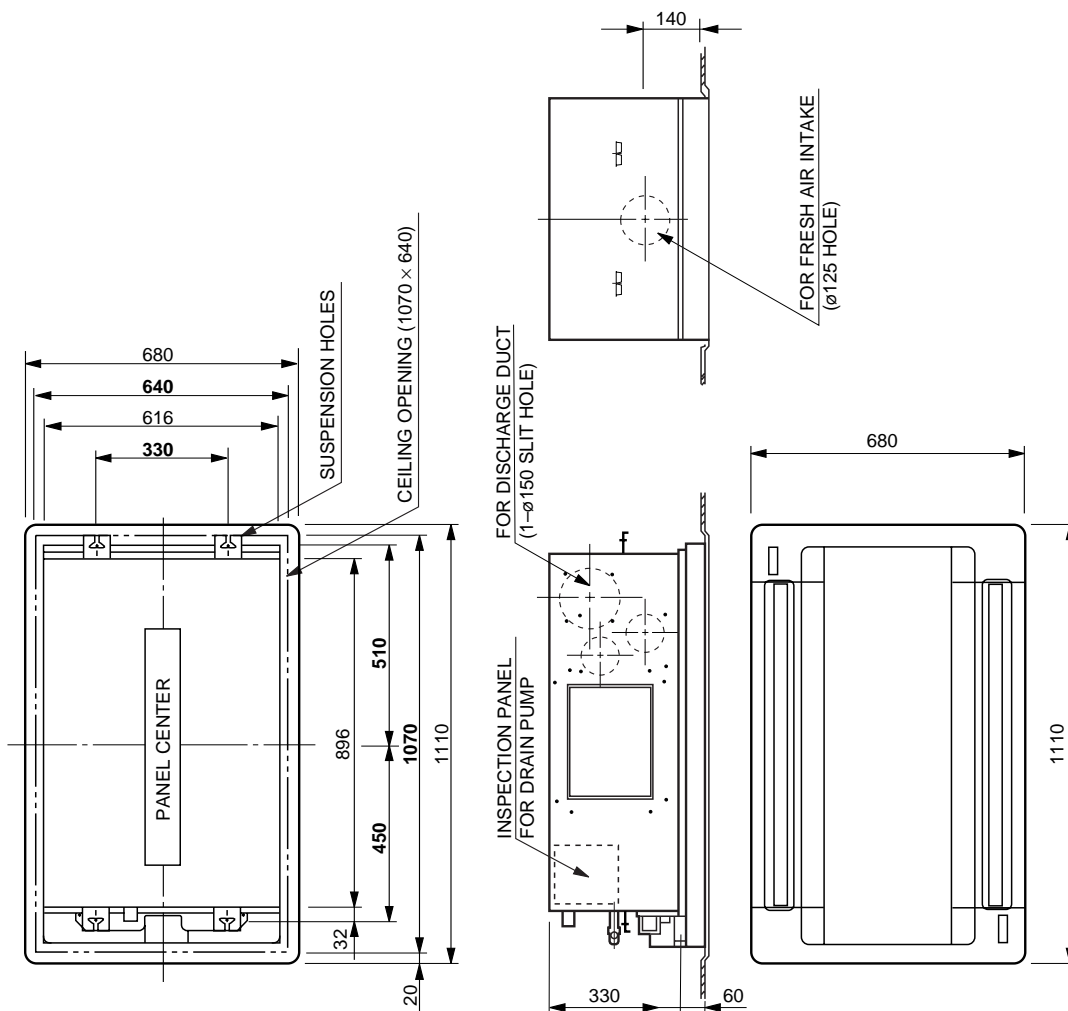

- ① Refrigerant liquid line (ø 9.52)
- ② Refrigerant gas line (ø 12.7)
- ③ Drain connection (25 A. O.D.32 mm)
- ④ Power supply entry

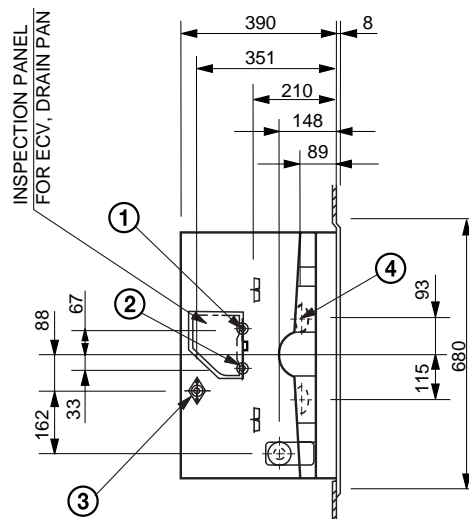

0206_S_I

3. 2-Way Air Discharge Semi-concealed Type

Indoor unit : 18, 25 Type

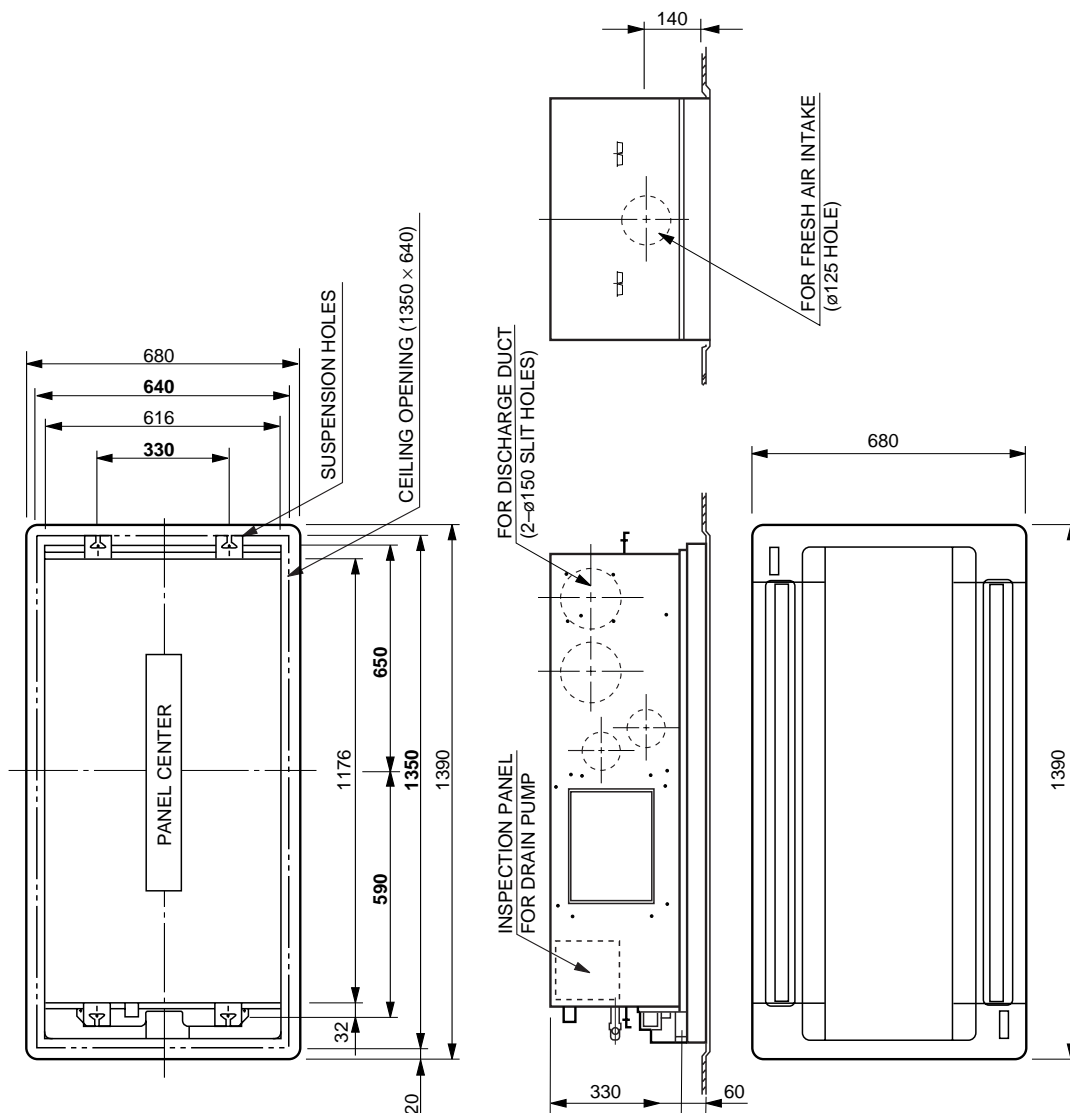

- ① Refrigerant liquid line (ø 9.52)
(In case of 25 type, use the tube connector.)
- ② Refrigerant gas line (ø 15.88)
- ③ Drain connection (25 A. O.D.32 mm)
- ④ Power supply entry

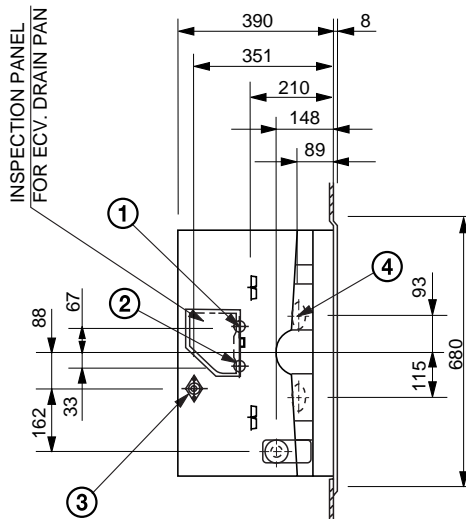

3. 2-Way Air Discharge Semi-concealed Type

3-5. Noise criterion curves

MODEL	: SPW-SR93GH56
SOUND LEVEL	: HIGH 32 dB(A), NC 29
	: LOW 25 dB(A), NC 21
CONDITION	: Center, Under the unit 1.5 m
SOURCE	: 220 - 230 - 240 V, 1 Phase, 50 Hz

MODEL	: SPW-SR123GH56
SOUND LEVEL	: HIGH 33 dB(A), NC 29
	: LOW 26 dB(A), NC 22
CONDITION	: Center, Under the unit 1.5 m
SOURCE	: 220 - 230 - 240 V, 1 Phase, 50 Hz

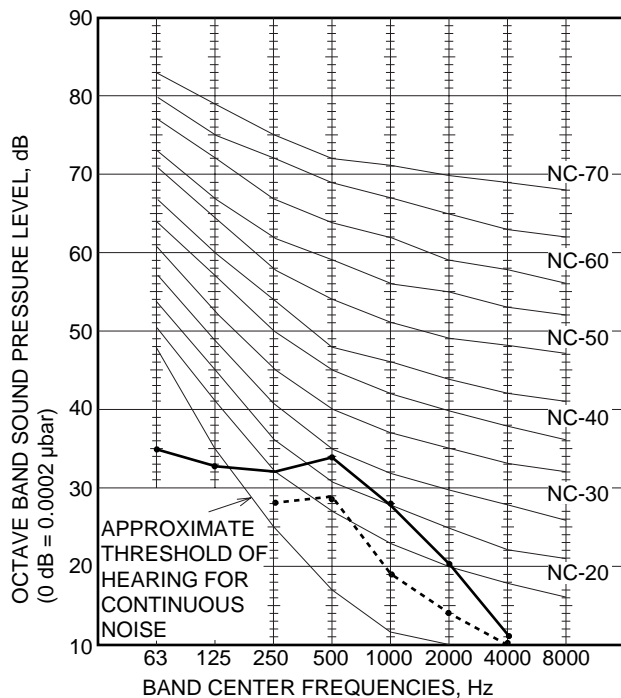
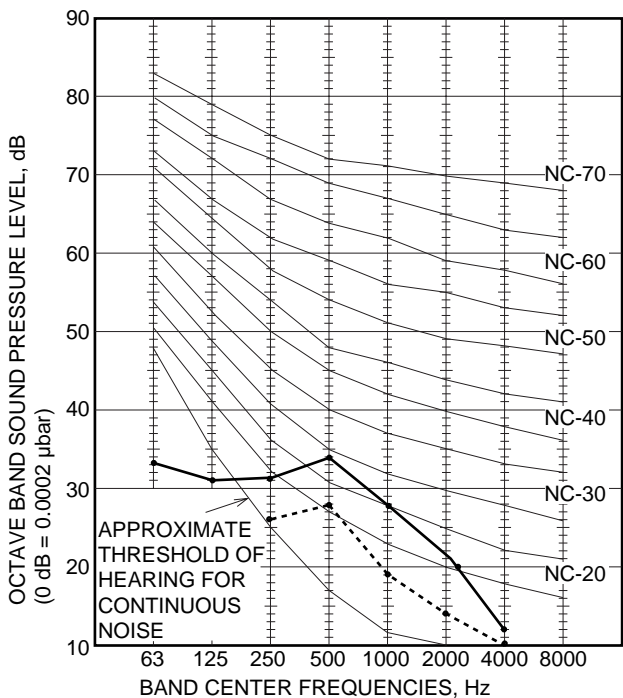

- REMARKS :**
1. Value obtained in the actual place where the unit is installed may be slightly higher than the values shown in this graph because of the conditions of operation, the structure of the building, the background noise and other factors.
 2. The test results were obtained from an anechoic room.

NOTE To evaluate "Noise level" the maximum number of the measured OCTAVE BAND SOUND PRESSURE LEVEL is used. Read the number on each BAND CENTER FREQUENCIES (horizontal axis) ranging from 63 Hz to 8000 Hz and select the maximum value (vertical axis) among them.

3. 2-Way Air Discharge Semi-concealed Type

MODEL	: SPW-SR183GH56
SOUND LEVEL	: HIGH 34 dB(A), NC 29
	: LOW 27 dB(A), NC 24
CONDITION	: Center, Under the unit 1.5 m
SOURCE	: 220 - 230 - 240 V, 1 Phase, 50 Hz

MODEL	: SPW-SR253GH56
SOUND LEVEL	: HIGH 37 dB(A), NC 33
	: LOW 30 dB(A), NC 29
CONDITION	: Distance 1 m, Under the unit 1.5 m
SOURCE	: 220 - 230 - 240 V, 1 Phase, 50 Hz

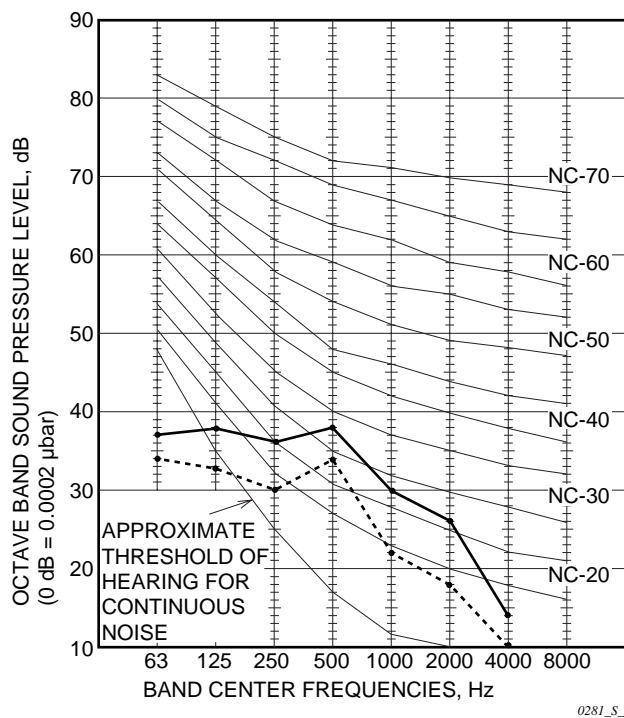
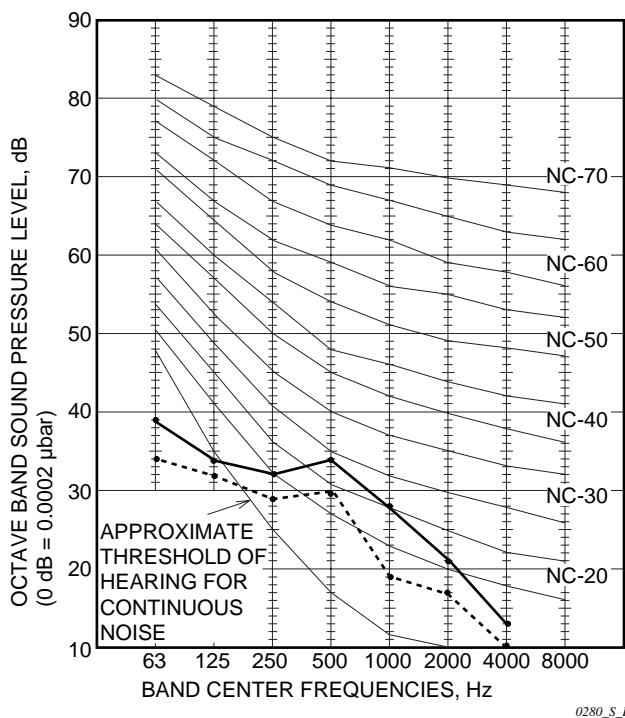

- REMARKS :**
1. Value obtained in the actual place where the unit is installed may be slightly higher than the values shown in this graph because of the conditions of operation, the structure of the building, the background noise and other factors.
 2. The test results were obtained from an anechoic room.

NOTE To evaluate "Noise level" the maximum number of the measured OCTAVE BAND SOUND PRESSURE LEVEL is used. Read the number on each BAND CENTER FREQUENCIES (horizontal axis) ranging from 63 Hz to 8000 Hz and select the maximum value (vertical axis) among them.



3. 2-Way Air Discharge Semi-concealed Type

3-6. Air throw distance chart

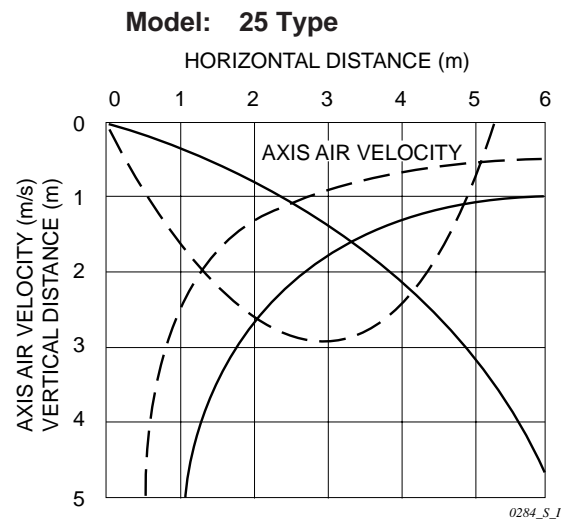
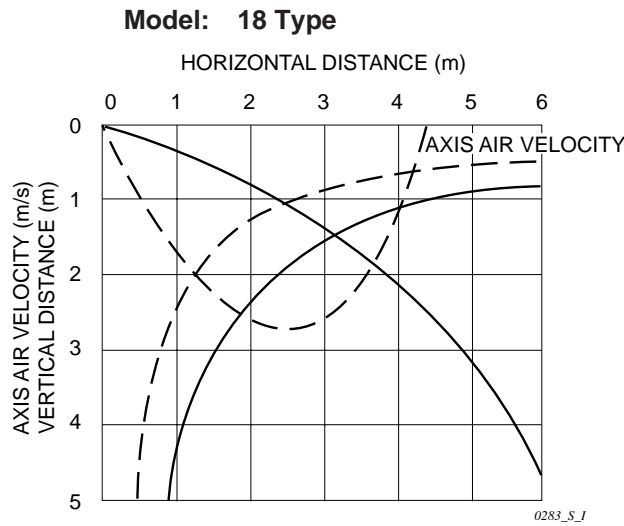
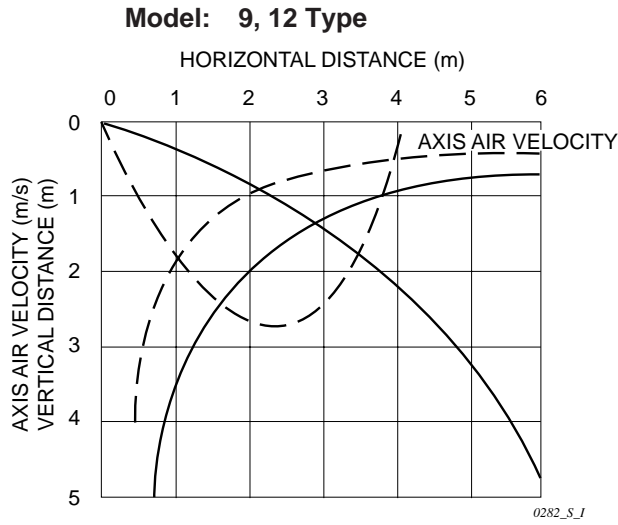

————— : LOUVER ANGLE 20° in Cooling mode
 - - - - - : LOUVER ANGLE 60° in Heating mode
 Condition Fan Speed : Hi
 Room air temp. : 27 °C DB in cooling mode
 20 °C DB in heating mode

4. 1-Way Air Discharge Semi-concealed Type

4-1. Specifications

Unit specifications (A)

MODEL No.	Indoor Unit		SPW-ASR93GH56	
POWER SOURCE			220 - 230 - 240 V / 1 phase / 50Hz	
PERFORMANCE			Cooling	Heating
Capacity	kW		2.8	3.2
	BTU / h		9,600	11,000
Air circulation (Hi / Me / Lo)	m ³ / h		480 / 420 / 360	
Moisture removal (High)	Liters / h		1.1	—
ELECTRICAL RATINGS				
Voltage rating	V		220 - 230 - 240	
Available voltage range	V		198 - 264	
Running amperes	A		0.36 - 0.37 - 0.38	0.28 - 0.29 - 0.30
Power input	W		65 - 70 - 75	50 - 55 - 60
Power factor	%		82 - 82 - 82	81 - 82 - 83
Fan motor locked rotor amperes	A		1 - 1 - 1	
FEATURES				
Controls	Microprocessor			
Timer	ON / OFF Timer (Max. 72 hr)			
Fan speeds (Indoor unit)	3 and Automatic control			
Air filter	Washable, easy access			
Refrigerant control	Electronic expansion valve			
Operation sound (Hi / Me / Lo)	dB-A		34 / 32 / 30	
Refrigerant tubing connections	Flare type			
Refrigerant tube diameter	Narrow tube mm (in.)	9.52 (3 / 8)		
	Wide tube mm (in.)	12.7 (1 / 2)		
Drain connection	25 A, OD32 mm			
Drain pump	Max. head 25 cm above drain connection			
Remote Controller	Optional (RCS-SH80TG)			
Refrigerant tubing kit / Accessories	Optional / —			
Color (Approximate value)	Munsell 10Y9.3 / 0.4, RAL 9010-GL			
DIMENSIONS & WEIGHT (include ceiling panel)			Unit dimensions	Package dimensions
Dimensions	Height	mm (in.)	370 (14 - 5 / 8)	485 (19 - 1 / 8)
	Width	mm (in.)	810 (31 - 7 / 8)	918 (38 - 1 / 8)
	Depth	mm (in.)	620 (24 - 3 / 8)	728 (28 - 5 / 8)
Net weight	kg (lbs.)		28 (62)	
Shipping weight	kg (lbs.)		40 (88)	
Shipping volume	m ³ (cu. ft)		0.324 (11.6)	

DATA SUBJECT TO CHANGE WITHOUT NOTICE.

Rated conditions

Cooling: Indoor air temperature 27 °C DB / 19 °C WB, Outdoor air temperature 35 °C DB

Heating: Indoor air temperature 20 °C DB , Outdoor air temperature 7 °C DB / 6 °C WB

4. 1-Way Air Discharge Semi-concealed Type

Unit specifications (B)

MODEL No.	Indoor Unit		SPW-ASR123GH56	
POWER SOURCE			220 - 230 - 240 V / 1 phase / 50Hz	
PERFORMANCE			Cooling	Heating
Capacity	kW		3.6	4.2
	BTU / h		12,000	14,000
Air circulation (Hi / Me / Lo)		m ³ / h	580 / 520 / 450	
Moisture removal (High)		Liters / h	1.7	—
ELECTRICAL RATINGS				
Voltage rating		V	220 - 230 - 240	
Available voltage range		V	198 - 264	
Running amperes		A	0.34 - 0.35 - 0.36	0.27 - 0.28 - 0.29
Power input		W	70 - 75 - 80	55 - 60 - 65
Power factor		%	93 - 93 - 93	93 - 93 - 93
Fan motor locked rotor amperes		A	1 - 1 - 1	
FEATURES				
Controls			Microprocessor	
Timer			ON / OFF Timer (Max. 72 hr)	
Fan speeds (Indoor unit)			3 and Automatic control	
Air filter			Washable, easy access	
Refrigerant control			Electronic expansion valve	
Operation sound (Hi / Me / Lo)		dB-A	38 / 35 / 31	
Refrigerant tubing connections			Flare type	
Refrigerant tube diameter	Narrow tube	mm (in.)	9.52 (3 / 8)	
	Wide tube	mm (in.)	12.7 (1 / 2)	
Drain connection			25 A, OD32 mm	
Drain pump			Max. head 25 cm above drain connection	
Remote Controller			Optional (RCS-SH80TG)	
Refrigerant tubing kit / Accessories			Optional / —	
Color (Approximate value)			Munsell 10Y9.3 / 0.4, RAL 9010-GL	
DIMENSIONS & WEIGHT (include ceiling panel)			Unit dimensions	Package dimensions
Dimensions	Height	mm (in.)	370 (14 - 5 / 8)	485 (19 - 1 / 8)
	Width	mm (in.)	810 (31 - 7 / 8)	918 (38 - 1 / 8)
	Depth	mm (in.)	620 (24 - 3 / 8)	728 (28 - 5 / 8)
Net weight		kg (lb.)	30 (66)	
Shipping weight		kg (lb.)	42 (93)	
Shipping volume		m ³ (cu. ft)	0.324 (11.6)	

DATA SUBJECT TO CHANGE WITHOUT NOTICE.

Rated conditions

Cooling: Indoor air temperature 27 °C DB / 19 °C WB, Outdoor air temperature 35 °C DB

Heating: Indoor air temperature 20 °C DB , Outdoor air temperature 7 °C DB / 6 °C WB

4. 1-Way Air Discharge Semi-concealed Type

4-2. Major component specifications

Indoor unit (A)

MODEL No.		SPW-ASR93GH56	
Source		220 - 230 - 240 V / 1 phase / 50Hz	
Controller P.C.B. Ass'y		CR-X253GH (Microprocessor)	
Fan (Number...diameter)	mm	Centrifugal (1 ... ø 190)	
Fan motor			
Model...Nominal output	W	UE6Q-21B3P ... 20 W	
Source		220 - 230 - 240 V / 1 phase / 50 Hz	
No. of pole...r.p.m. (230 V, High)	rpm.	6P ... 696	
Coil resistance (Ambient temperature 20 °C)	Ω	BRN – WHT : 290.0 ORG – YEL : 241.2 WHT – VLT : 117.4 YEL – PNK : 45.74 VLT – ORG : 39.32	
Safety device			
Operating temperature	Open °C	130 ± 5	
	Close °C	(115 ± 5)	
Run capacitor	VAC, μF	440 V, 0.6 μF	
Electronic expansion valve			
Coil		LAM-MDI2ST-1	
Coil resistance (at 20 °C)	Ω	ORG – GRY : 48 , YEL – GRY : 48 RED – GRY : 48 , BLK – GRY : 48	
Valve body		LAM-B30YPST-1	
Heat exchanger			
Coil		Aluminum plate fin / Copper tube	
Rows...fin pitch	mm	2 ... 2.0	
Face area	m ²	0.144	
Panel			
Model No.		PNR-AS123GH	
Drain Pump			
Rated		V, W	
Total head & capacity		AC 230 V, 50 Hz, 14.7 W	
		400 mm, 600 cc/min	

1

4. 1-Way Air Discharge Semi-concealed Type

Indoor unit (B)

MODEL No.		SPW-ASR123GH56	
Source		220 - 230 - 240 V / 1 phase / 50Hz	
Controller P.C.B. Ass'y		CR-X253GH (Microprocessor)	
Fan (Number...diameter)	mm	Centrifugal (1 ... ø 190)	
Fan motor			
Model...Nominal output	W	UE6Q-21B3P ... 20 W	
Source		220 - 230 - 240 V / 1 phase / 50 Hz	
No. of pole...r.p.m. (230 V, High)	rpm.	6P ... 771	
Coil resistance (Ambient temperature 20 °C)	Ω	BRN – WHT : 290.0 ORG – YEL : 241.2 WHT – VLT : 117.4 YEL – PNK : 45.74 VLT – ORG : 39.32	
Safety device			
Operating temperature	Open °C	130 ± 5	
	Close °C	(115 ± 5)	
Run capacitor	VAC, μF	440 V, 1.0 μF	
Electronic expansion valve			
Coil		LAM-MDI2ST-1	
Coil resistance (at 20 °C)	Ω	ORG – GRY : 48 , YEL – GRY : 48 RED – GRY : 48 , BLK – GRY : 48	
Valve body		LAM-B30YPST-1	
Heat exchanger			
Coil		Aluminum plate fin / Copper tube	
Rows...fin pitch	mm	3 ... 2.0	
Face area	m ²	0.144	
Panel			
Model No.		PNR-AS123GH	
Drain Pump			
Rated		V, W	
Total head & capacity		AC 230 V, 50 Hz, 14.7 W 400 mm, 600 cc/min	

1

4. 1-Way Air Discharge Semi-concealed Type

4-3. Other component specifications

MODEL NO.	Indoor Unit	SPW-ASR93 · 123GH56	
Power Transformer		ATR-II215TB	
Rated			
Primary	V, Hz	AC 230 V, 50 Hz	
Secondary		10.2 V 1.4 A	
		14 V 0.5 A	
Coil resistance	Ω	WHT –WHT : 112 , BRN – BRN : 0.5 RED – RED : 2.3	
Thermal cut off temperature	°C	150	
Thermistor (Coil sensor)		PBC-41E-S14 , PBC-41E-S25	
Resistance	KΩ	-10 °C : 23.7 ± 5 % , 20 °C : 6.5 ± 5 % -5 °C : 18.8 ± 5 % , 30 °C : 4.4 ± 5 % 0 °C : 15.0 ± 5 % , 40 °C : 3.1 ± 5 % 5 °C : 12.1 ± 5 % , 45 °C : 2.6 ± 5 % 10 °C : 9.7 ± 5 %	
Thermistor (Room or coil sensor)		KTEC-35-S6	
Resistance	KΩ	0 °C : 16.5 ± 5 % , 40 °C : 2.7 ± 5 % 5 °C : 12.8 ± 5 % , 45 °C : 2.2 ± 5 % 10 °C : 10.0 ± 5 % , 50 °C : 1.8 ± 5 % 20 °C : 6.3 ± 5 % , 55 °C : 1.5 ± 5 % 30 °C : 4.0 ± 5 %	
Electronic expansion valve			
Valve body		LAM-B30YPST-1	
Coil		LAM-MDI2ST-1	
Drain pump		WP20SL-14	
Rated		AC 230 V, 14.7 W	
Float switch		FS-0218-102	
Rated (Contact rated)		DC 12 V, 25 W	

1

4. 1-Way Air Discharge Semi-concealed Type

4-4. Dimensional data

Indoor unit : 9, 12 Type

1

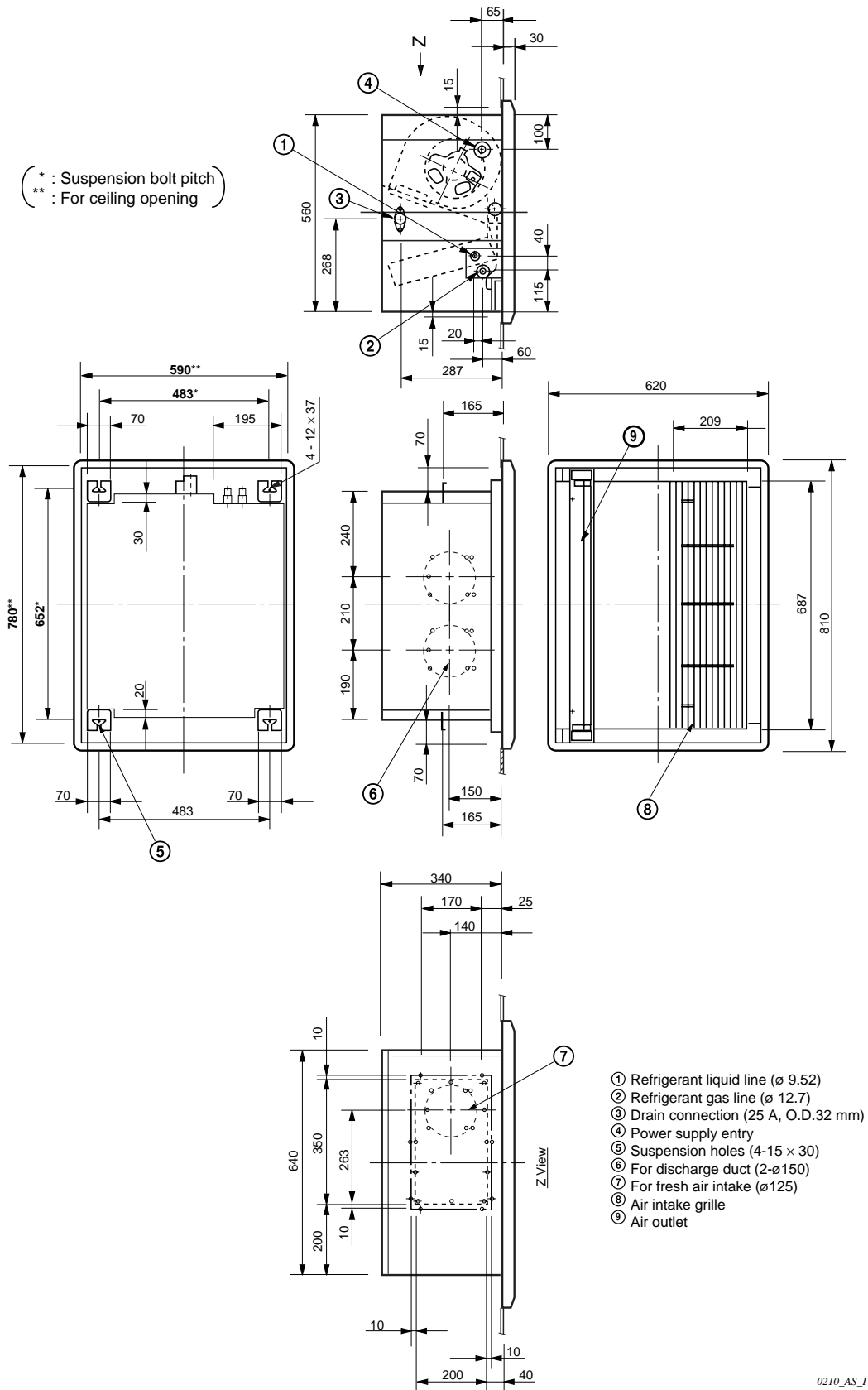

4. 1-Way Air Discharge Semi-concealed Type

4-5. Noise criterion curves

MODEL	: SPW-ASR93GH56
SOUND LEVEL	: HIGH 34 dB(A), NC 25 LOW 30 dB(A), NC 22
CONDITION	: Center, Under the unit 1.5 m
SOURCE	: 220 - 230 - 240 V, 1 Phase, 50 Hz

MODEL	: SPW-ASR123GH56
SOUND LEVEL	: HIGH 38 dB(A), NC 32 LOW 31 dB(A), NC 25
CONDITION	: Center, Under the unit 1.5 m
SOURCE	: 220 - 230 - 240 V, 1 Phase, 50 Hz

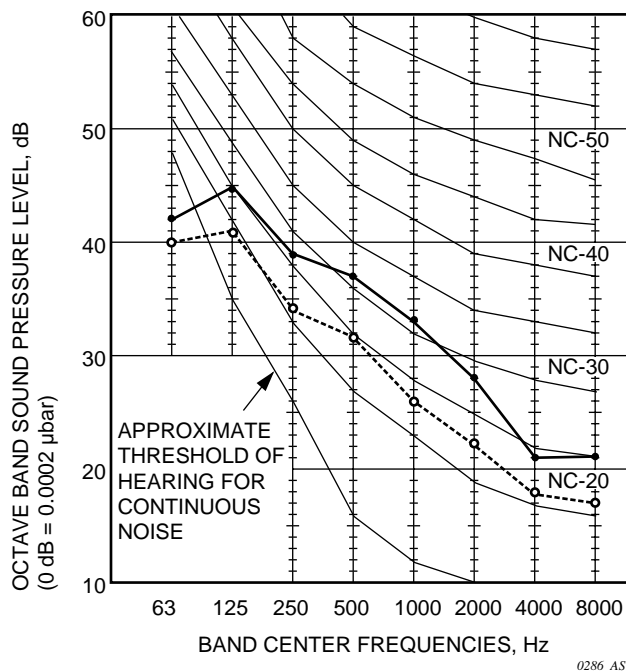
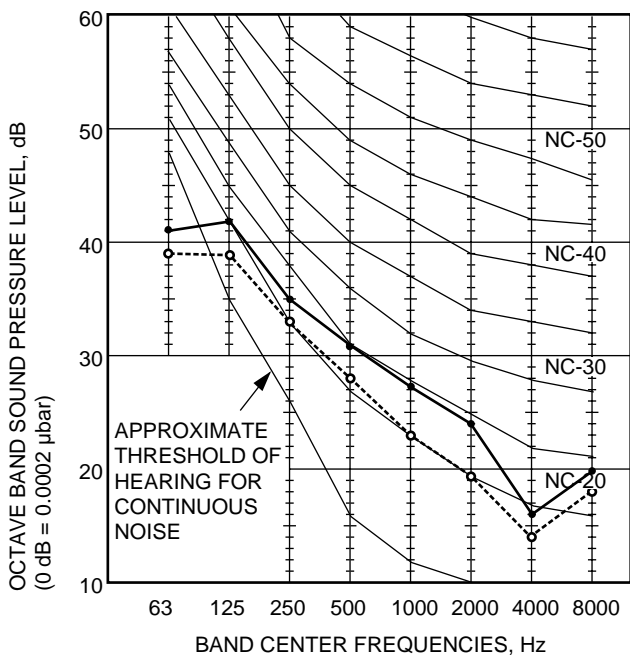

- REMARKS :**
1. Value obtained in the actual place where the unit is installed may be slightly higher than the values shown in this graph because of the conditions of operation, the structure of the building, the background noise and other factors.
 2. The test results were obtained from an anechoic room.

NOTE To evaluate "Noise level" the maximum number of the measured OCTAVE BAND SOUND PRESSURE LEVEL is used. Read the number on each BAND CENTER FREQUENCIES (horizontal axis) ranging from 63 Hz to 8000 Hz and select the maximum value (vertical axis) among them.



4. 1-Way Air Discharge Semi-concealed Type

4-6. Air throw distance chart

Model: 9 Type

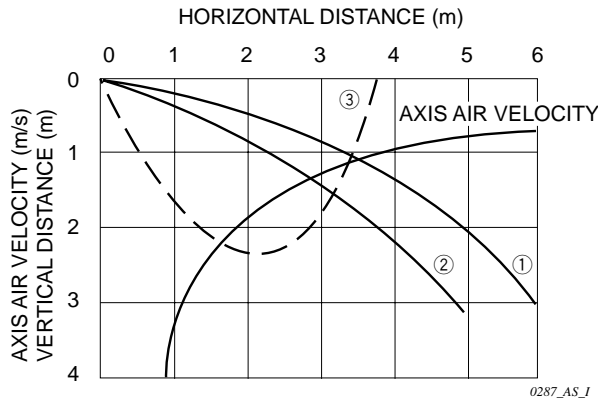

Model: 12 Type

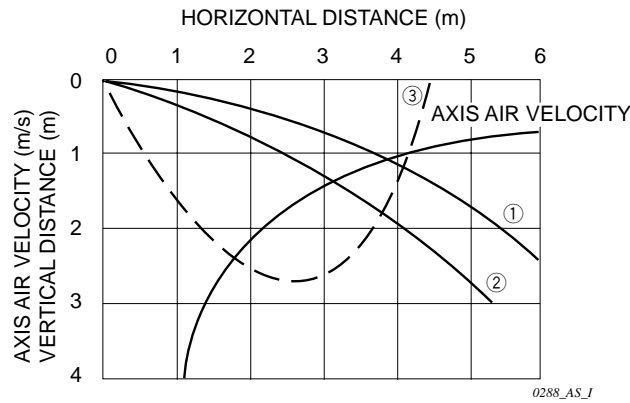

- ①: LOUVER ANGLE 10° in cooling mode
- ②: LOUVER ANGLE 20° in cooling mode
- ③: LOUVER ANGLE 60° in heating mode

Condition Fan Speed : Hi

Room air temp. : 27 °C DB in cooling mode
20 °C DB in heating mode

5. Wall Mounted Type

5-1. Specifications

Unit specifications (A)

MODEL No.	Indoor Unit		SPW-KR93GH56	
POWER SOURCE			220 - 230 - 240 V / 1 phase / 50Hz	
PERFORMANCE			Cooling	Heating
Capacity	kW		2.8	3.2
	BTU / h		9,600	11,000
Air circulation (Hi / Me / Lo)	m ³ / h		450 / 390 / 340	
Moisture removal (High)	Liters / h		1.3	—
ELECTRICAL RATINGS				
Voltage rating	V		220 - 230 - 240	
Available voltage range	V		198 - 264	
Running amperes	A		0.22 - 0.22 - 0.23	0.22 - 0.22 - 0.23
Power input	W		47 - 50 - 54	47 - 50 - 54
Power factor	%		97 - 98 - 98	97 - 98 - 98
Fan motor locked rotor amperes	A		1 - 1 - 1	
FEATURES				
Controls	Microprocessor			
Timer	ON / OFF Timer (Max. 72 hr)			
Fan speeds (Indoor unit)	3 and Automatic control			
Air filter	Washable, easy access			
Refrigerant control	Electronic expansion valve			
Operation sound (Hi / Me / Lo)	dB-A		38 / 33 / 30	
Refrigerant tubing connections	Flare type			
Refrigerant tube diameter	Narrow tube	mm (in)	9.52 (3 / 8)	
	Wide tube	mm (in)	12.7 (1 / 2)	
Drain connection	20 A, OD26 mm			
Remote Controller	Optional (RCS-SH80TG)			
Refrigerant tubing kit / Accessories	Optional / Hanging wall bracket			
Color (Approximate value)	Munsell 3.0Y8.6 / 0.8, RAL 1013-GL			
DIMENSIONS & WEIGHT			Unit dimensions	Package dimensions
Dimensions	Height	mm (in)	360 (14 - 1 / 8)	282 (11 - 1 / 8)
	Width	mm (in)	1,000 (39 - 3 / 8)	1,080 (42 - 1 / 2)
	Depth	mm (in)	205 (8 - 1 / 16)	443 (17 - 1 / 2)
Net weight	kg (lb)		15 (33)	
Shipping weight	kg (lb)		19 (42)	
Shipping volume	m ³ (cu. ft)		0.135 (4.8)	

DATA SUBJECT TO CHANGE WITHOUT NOTICE.

Rated conditions

Cooling: Indoor air temperature 27 °C DB / 19 °C WB, Outdoor air temperature 35 °C DB

Heating: Indoor air temperature 20 °C DB, Outdoor air temperature 7 °C DB / 6 °C WB

5. Wall Mounted Type

Unit specifications (B)

MODEL No.		Indoor Unit		SPW-KR123GH56	
POWER SOURCE				220 - 230 - 240 V / 1 phase / 50Hz	
PERFORMANCE				Cooling	Heating
Capacity		kW BTU / h	3.6 12,000	4.2 14,000	
Air circulation (Hi / Me / Lo)		m ³ / h	630 / 490 / 430		
Moisture removal (High)		Liters / h	1.6	—	
ELECTRICAL RATINGS					
Voltage rating		V	220 - 230 - 240		
Available voltage range		V	198 - 264		
Running amperes		A	0.24 - 0.24 - 0.25	0.24 - 0.24 - 0.25	
Power input		W	51 - 54 - 59	51 - 54 - 59	
Power factor		%	97 - 98 - 98	97 - 98 - 98	
Fan motor locked rotor amperes		A	1 - 1 - 1		
FEATURES					
Controls		Microprocessor			
Timer		ON / OFF Timer (Max. 72 hr)			
Fan speeds (Indoor unit)		3 and Automatic control			
Air filter		Washable, easy access			
Refrigerant control		Electronic expansion valve			
Operation sound (Hi / Me / Lo)		dB-A	40 / 37 / 34		
Refrigerant tubing connections		Flare type			
Refrigerant tube diameter	Narrow tube	mm (in)	9.52 (3 / 8)		
	Wide tube	mm (in)	12.7 (1 / 2)		
Drain connection		20 A, OD26 mm			
Remote Controller		Optional (RCS-SH80TG)			
Refrigerant tubing kit / Accessories		Optional / Hanging wall bracket			
Color (Approximate value)		Munsell 3.0Y8.6 / 0.8, RAL 1013-GL			
DIMENSIONS & WEIGHT					
Dimensions	Height	mm (in)	360 (14 - 1 / 8)		282 (11 - 1 / 8)
	Width	mm (in)	1,000 (39 - 3 / 8)		1,080 (42 - 1 / 2)
	Depth	mm (in)	205 (8 - 1 / 16)		443 (17 - 1 / 2)
Net weight		kg (lb)	15 (33)		
Shipping weight		kg (lb)	19 (42)		
Shipping volume		m ³ (cu. ft)	0.135 (4.8)		

DATA SUBJECT TO CHANGE WITHOUT NOTICE.

Rated conditions

Cooling: Indoor air temperature 27 °C DB / 19 °C WB, Outdoor air temperature 35 °C DB

Heating: Indoor air temperature 20 °C DB , Outdoor air temperature 7 °C DB / 6 °C WB

5. Wall Mounted Type

Unit specifications (C)

MODEL No.	Indoor Unit		SPW-KR183GH56	
POWER SOURCE			220 - 230 - 240 V / 1 phase / 50Hz	
PERFORMANCE			Cooling	Heating
Capacity	kW		5.0	6.0
	BTU / h		17,000	20,000
Air circulation (Hi / Me / Lo)	m ³ / h		800 / 660 / 520	
Moisture removal (High)	Liters / h		2.5	—
ELECTRICAL RATINGS				
Voltage rating	V		220 - 230 - 240	
Available voltage range	V		198 - 264	
Running amperes	A		0.35 - 0.35 - 0.36	0.35 - 0.35 - 0.36
Power input	W		75 - 80 - 85	75 - 80 - 85
Power factor	%		97 - 97 - 98	97 - 97 - 98
Fan motor locked rotor amperes	A		1 - 1 - 1	
FEATURES				
Controls	Microprocessor			
Timer	ON / OFF Timer (Max. 72 hr)			
Fan speeds (Indoor unit)	3 and Automatic control			
Air filter	Washable, easy access			
Refrigerant control	Electronic expansion valve			
Operation sound (Hi / Me / Lo)	dB-A		46 / 42 / 37	
Refrigerant tubing connections	Flare type			
Refrigerant tube diameter	Narrow tube	mm (in)	9.52 (3 / 8)	
	Wide tube	mm (in)	15.88 (5 / 8)	
Drain connection	20 A, OD26 mm			
Remote Controller	Optional (RCS-SH80TG)			
Refrigerant tubing kit / Accessories	Optional / Hanging wall bracket			
Color (Approximate value)	Munsell 3.0Y8.6 / 0.8, RAL 1013-GL			
DIMENSIONS & WEIGHT				
Dimensions	Height	mm (in)	360 (14 - 1 / 8)	282 (11 - 1 / 8)
	Width	mm (in)	1,000 (39 - 3 / 8)	1,080 (42 - 1 / 2)
	Depth	mm (in)	205 (8 - 1 / 16)	443 (17 - 1 / 2)
Net weight	kg (lb)		15 (33)	
Shipping weight	kg (lb)		19 (42)	
Shipping volume	m ³ (cu. ft)		0.135 (4.8)	

DATA SUBJECT TO CHANGE WITHOUT NOTICE.

Rated conditions

Cooling: Indoor air temperature 27 °C DB / 19 °C WB, Outdoor air temperature 35 °C DB

Heating: Indoor air temperature 20 °C DB , Outdoor air temperature 7 °C DB / 6 °C WB

5. Wall Mounted Type

5-2. Major component specifications

Indoor unit (A)

MODEL No.		SPW-KR93GH56	
Source		220 - 230 - 240 V / 1 phase / 50Hz	
Controller P.C.B. Ass'y		CR-X253GH (Microprocessor)	
Fan (Number...diameter)	mm	Cross-flow (1 ... ø 81 / L 610)	
Fan motor			
Model...Nominal output	W	UF2Q-21C5P ... 20 W	
Source		220 - 230 - 240 V / 1 phase / 50 Hz	
No. of pole...r.p.m. (230 V, High)	rpm.	2 ... 1,170	
Coil resistance (Ambient temperature 20 °C)	Ω	BRN – WHT : 208.5 ORG – YEL : 72.32 WHT – VLT : 84.20 YEL – PNK : 44.89 VLT – ORG : 17.59	
Safety device			
Operating temperature	Open °C	130 ± 5	
	Close °C	(115 ± 5)	
Run capacitor	VAC, μF	440 V, 0.8 μF	
Electronic expansion valve			
Coil		LAM-MD12ST-1	
Coil resistance (at 20 °C)	Ω	ORG – RED : 48 , YEL – BRN : 48 RED – WHT : 48 , BRN – BLU : 48	
Valve body		LAM-B30YPST-1	
Heat exchanger			
Coil		Aluminum plate fin / Copper tube	
Rows...fin pitch	mm	2 ... 1.5	
Face area	m ²	0.172	
Auto louver motor		M2LJ24ZE31	
Rated		AC 230 V-50 Hz	
No. of pole...r.p.m.	rpm.	8P – 2.5	
Nominal output	W	3	
Coil resistance (at 25 °C)	Ω	16.450 Ω ± 15 %	

5. Wall Mounted Type

Indoor unit (B)

MODEL No.		SPW- KR123GH56	
Source		220 - 230 - 240 V / 1 phase / 50Hz	
Controller P.C.B. Ass'y		CR-X253GH (Microprocessor)	
Fan (Number...diameter)	mm	Cross-flow (1 ... ø 81 / L 610)	
Fan motor			
Model...Nominal output	W	UF2Q – 21C5P ... 20 W	
Source		220 - 230 - 240 V / 1 phase / 50 Hz	
No. of pole...r.p.m. (230 V, High)	rpm.	2 ... 1,280	
Coil resistance (Ambient temperature 20 °C)	Ω	BRN – WHT : 208.5 ORG – YEL : 72.32 WHT – VLT : 84.20 YEL – PNK : 44.89 VLT – ORG : 17.59	
Safety device			
Operating temperature	Open °C	130 ± 5	
	Close °C	(115 ± 5)	
Run capacitor	VAC, μF	440 V, 1.0 μF	
Electronic expansion valve			
Coil		LAM-MD12ST-1	
Coil resistance (at 20 °C)	Ω	ORG – RED : 48 , YEL – BRN : 48 RED – WHT : 48 , BRN – BLU : 48	
Valve body		LAM-B30YPST-1	
Heat exchanger			
Coil		Aluminum plate fin / Copper tube	
Rows...fin pitch	mm	2 ... 1.5	
Face area	m ²	0.172	
Auto louver motor			
Rated		AC 230 V – 50 Hz	
No. of pole...r.p.m.	rpm.	8P – 2.5	
Nominal output	W	3	
Coil resistance (at 25 °C)	Ω	16.450 Ω ± 15 %	

1

5. Wall Mounted Type

Indoor unit (C)

MODEL No.		SPW-KR183GH56	
Source		220 - 230 - 240 V / 1 phase / 50Hz	
Controller P.C.B. Ass'y		CR-X253GH (Microprocessor)	
Fan (Number...diameter)	mm	Cross-flow (1 ... ø 81/L610)	
Fan motor			
Model...Nominal output	W	UF2Q-21B3P ... 20 W	
Source		220 - 230 - 240 V / 1 phase / 50 Hz	
No. of pole...r.p.m. (230 V, High)	rpm.	2 ... 1,810 rpm (at 220 V, 1,700 rpm)	
Coil resistance (Ambient temperature 20 °C)	Ω	BRN – WHT : 140.7 ORG – YEL : 47.90 WHT – VLT : 40.83 YEL – PNK : 20.21 VLT – ORG : 13.16	
Safety device			
Operating temperature	Open °C	145 ± 2	
	Close °C	—	
Run capacitor	VAC, μF	440 V, 2.5 μF	
Electronic expansion valve			
Coil		LAM-MD12ST-1	
Coil resistance (at 20 °C)	Ω	ORG – RED : 48 , YEL – BRN : 48 RED – WHT : 48 , BRN – BLU : 48	
Valve body		LAM-B30YPST-1	
Heat exchanger			
Coil		Aluminum plate fin / Copper tube	
Rows...fin pitch	mm	2 ... 1.5	
Face area	m ²	0.172	
Auto louver motor			
Rated		AC 230 V – 50 Hz	
No. of pole...r.p.m.	rpm.	8P – 2.5	
Nominal output		3	
Coil resistance (at 25 °C)	Ω	16.450 Ω ± 15%	

5. Wall Mounted Type

5-3. Other component specifications

MODEL NO.	Indoor Unit	SPW-KR93 ~ 183GH56	
Power Transformer		ATR-II215TB	
Rated			
Primary	V, Hz	AC 230 V, 50 Hz	
Secondary		10.2 V 1.4 A	
		14 V 0.5 A	
Coil resistance	Ω	WHT – WHT : 112 , BRN – BRN : 0.5 RED – RED : 2.3	
Thermal cut off temperature	$^{\circ}\text{C}$	150	
Thermistor (Coil sensor)		PBC-41E-S25 , PBC-41E-S4	
Resistance	$\text{K}\Omega$	-10 $^{\circ}\text{C}$: 23.7 \pm 5 % , 20 $^{\circ}\text{C}$: 6.5 \pm 5 % -5 $^{\circ}\text{C}$: 18.8 \pm 5 % , 30 $^{\circ}\text{C}$: 4.4 \pm 5 % 0 $^{\circ}\text{C}$: 15.0 \pm 5 % , 40 $^{\circ}\text{C}$: 3.1 \pm 5 % 5 $^{\circ}\text{C}$: 12.1 \pm 5 % , 45 $^{\circ}\text{C}$: 2.6 \pm 5 % 10 $^{\circ}\text{C}$: 9.7 \pm 5 %	
Thermistor (Room or coil sensor)		KTEC-35-S6	
Resistance	$\text{K}\Omega$	0 $^{\circ}\text{C}$: 16.5 \pm 5 % , 40 $^{\circ}\text{C}$: 2.7 \pm 5 % 5 $^{\circ}\text{C}$: 12.8 \pm 5 % , 45 $^{\circ}\text{C}$: 2.2 \pm 5 % 10 $^{\circ}\text{C}$: 10.0 \pm 5 % , 50 $^{\circ}\text{C}$: 1.8 \pm 5 % 20 $^{\circ}\text{C}$: 6.3 \pm 5 % , 55 $^{\circ}\text{C}$: 1.5 \pm 5 % 30 $^{\circ}\text{C}$: 4.0 \pm 5 %	
Electronic expansion valve			
Valve body		LAM-B30YPST-1	
Coil		LAM-MD12ST-1	

1

5. Wall Mounted Type

5-4. Dimensional data

Indoor unit : 9, 12, 18 Type

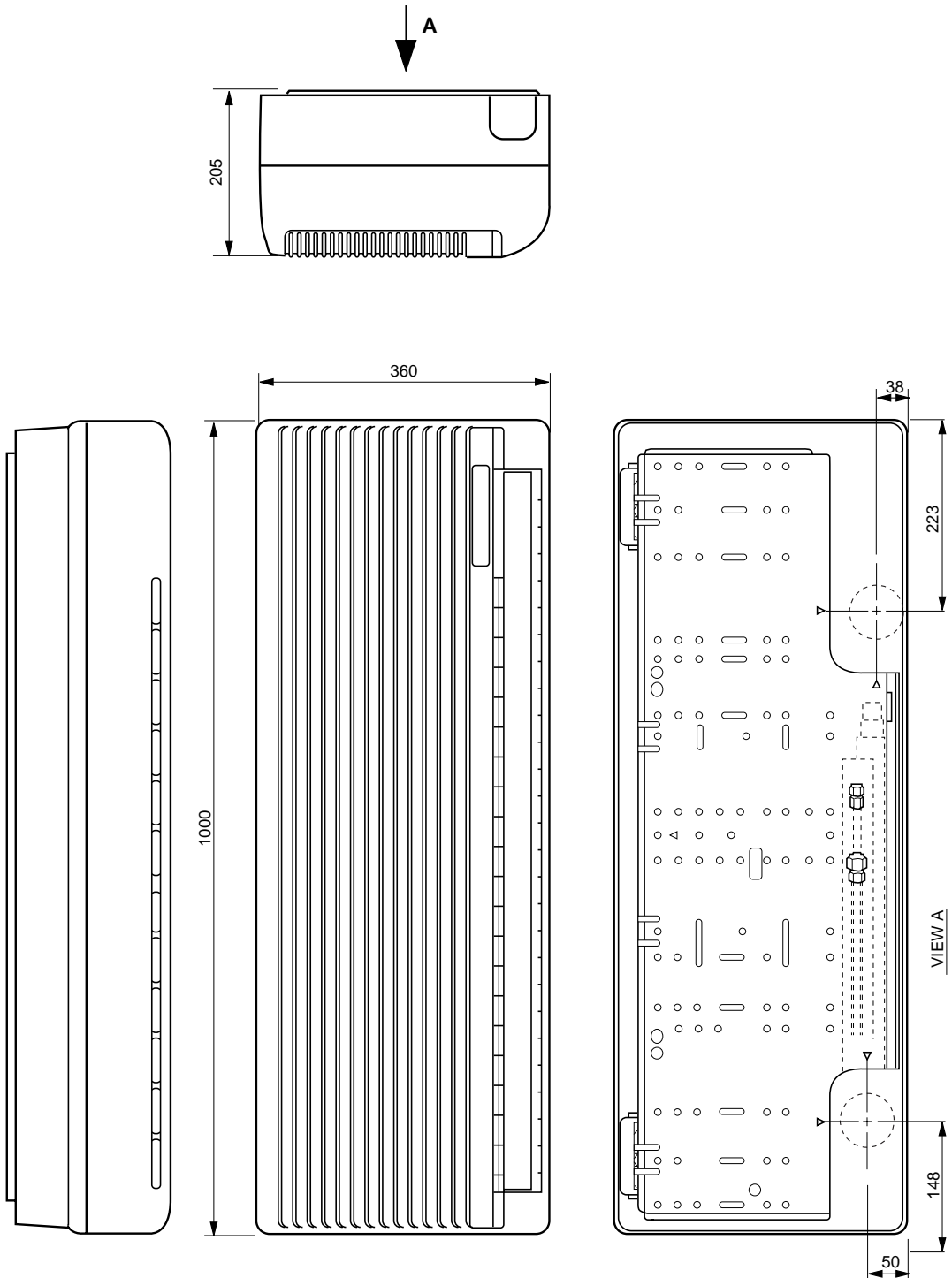

0289_K-1

TYPE OF COPPER TUBE

TUBE	OUTER DIAMETER	NOTES
NARROW	9.52 mm (3 / 8 inch)	9, 12, 18 type
WIDE	12.7 mm (1 / 2 inch)	9, 12 type
	15.88 mm (5 / 8 inch)	18 type

5. Wall Mounted Type

5-5. Noise criterion curves

MODEL	: SPW-KR93GH56
SOUND LEVEL	: HIGH 38 dB(A), NC 33
	: LOW 30 dB(A), NC 25
CONDITION	: Distance 1 m, Under the unit 1 m
SOURCE	: 220 - 230 - 240 V, 1 Phase, 50 Hz

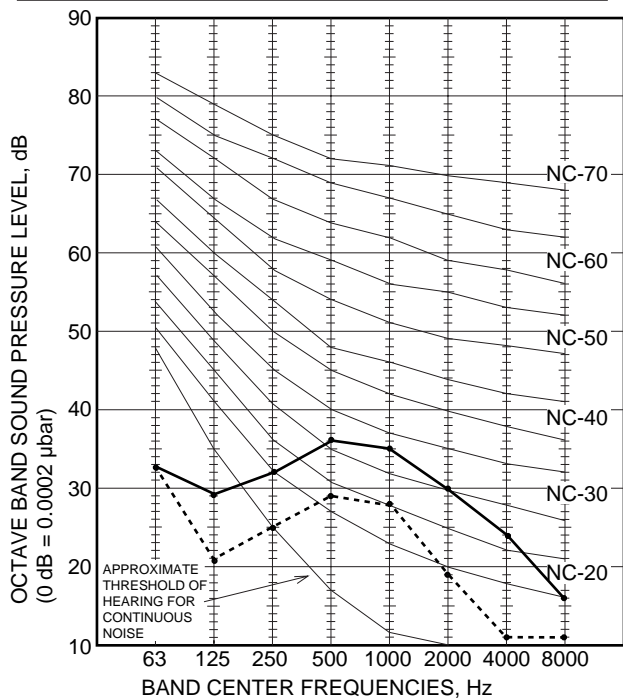

0290_K_1

MODEL	: SPW-KR123GH56
SOUND LEVEL	: HIGH 40 dB(A), NC 35
	: LOW 34 dB(A), NC 29
CONDITION	: Distance 1 m, Under the unit 1 m
SOURCE	: 220 - 230 - 240 V, 1 Phase, 50 Hz

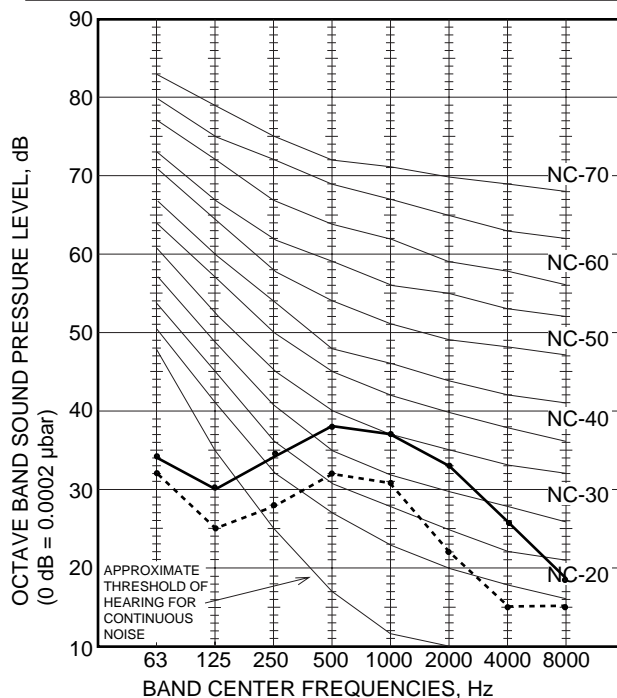

0291_K_1

MODEL	: SPW-KR183GH56
SOUND LEVEL	: HIGH 46 dB(A), NC 41
	: LOW 37 dB(A), NC 32
CONDITION	: Distance 1 m, Under the unit 1 m
SOURCE	: 220 - 230 - 240 V, 1 Phase, 50 Hz

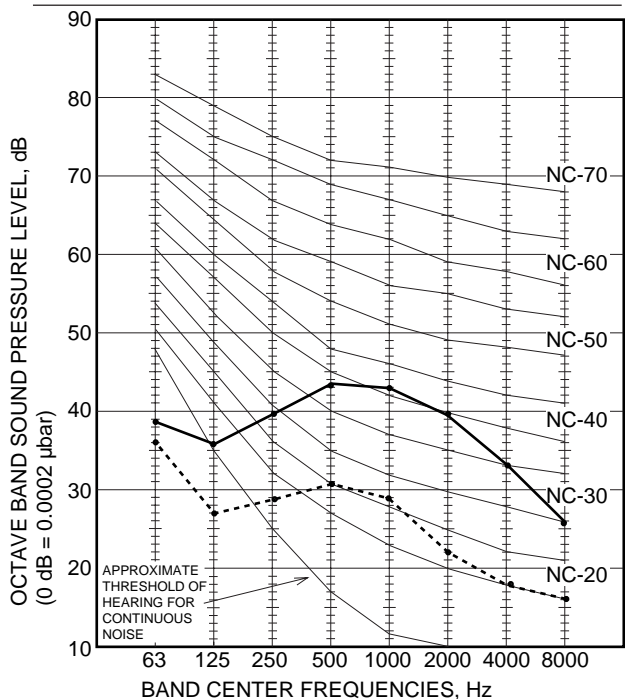

0292_K_1

- REMARKS:**
1. Value obtained in the actual place where the unit is installed may be slightly higher than the values shown in this graph because of the conditions of operation, the structure of the building, the background noise and other factors.
 2. The test results were obtained from an anechoic room.

NOTE To evaluate "Noise level" the maximum number of the measured OCTAVE BAND SOUND PRESSURE LEVEL is used. Read the number on each BAND CENTER FREQUENCIES (horizontal axis) ranging from 63 Hz to 8000 Hz and select the maximum value (vertical axis) among them.

SM830063



5. Wall Mounted Type

5-6. Air throw distance chart



Model: 9 Type

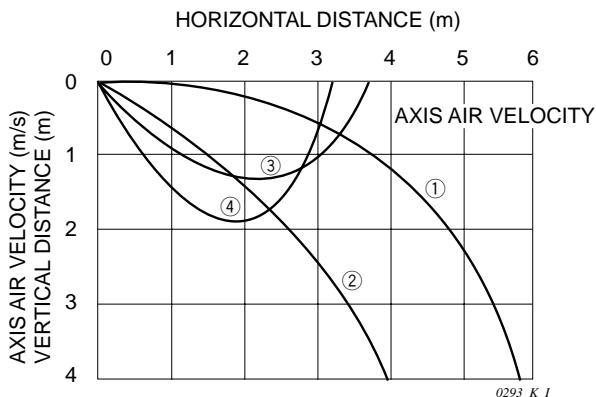

Model: 12 Type

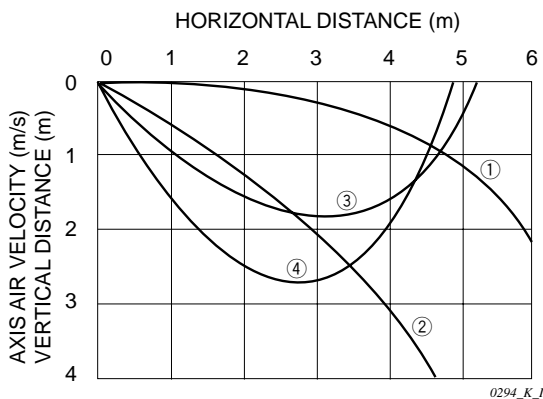

Model: 18 Type

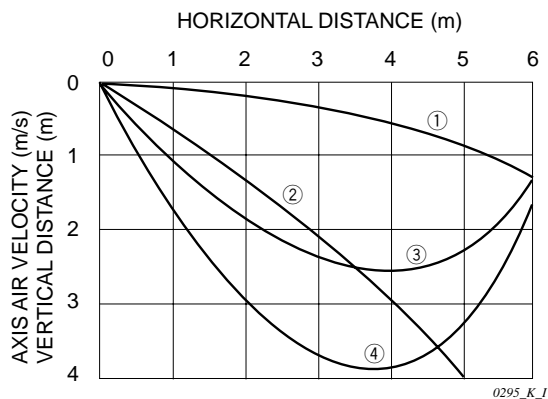

Condition Fan Speed : Hi
 Room air temp. : 27 °C DB in cooling mode
 20 °C DB in heating mode

①: LOUVER ANGLE 0° in cooling mode
 ②: LOUVER ANGLE 30° in cooling mode
 ③: LOUVER ANGLE 45° in heating mode
 ④: LOUVER ANGLE 60° in heating mode

6. Ceiling Mounted Type

6-1. Specifications

Unit specifications (A)

MODEL No.	Indoor Unit		SPW-TR183GH56	
POWER SOURCE			220 - 230 - 240 V / 1 phase / 50Hz	
PERFORMANCE			Cooling	Heating
Capacity	kW		5.6	6.3
	BTU / h		19,000	21,000
Air circulation (Hi / Me / Lo)		m ³ / h	780 / 660 / 540	
Moisture removal (High)		Liters / h	2.8	—
ELECTRICAL RATINGS				
Voltage rating		V	220 - 230 - 240	
Available voltage range		V	198 - 264	
Running amperes		A	0.40 - 0.40 - 0.40	0.30 - 0.30 - 0.31
Power input		W	84 - 88 - 93	64 - 68 - 73
Power factor		%	95 - 96 - 97	97 - 99 - 98
Fan motor locked rotor amperes		A	1 - 1 - 1	
FEATURES				
Controls			Microprocessor	
Timer			ON / OFF Timer (Max. 72 hr)	
Fan speeds (Indoor unit)			3 and Automatic control	
Air filter			Washable, easy access, long life (2,500 hr)	
Refrigerant control			Electronic expansion valve	
Operation sound (Hi / Me / Lo)		dB-A	36 / 33 / 30	
Refrigerant tubing connections			Flare type	
Refrigerant tube diameter	Narrow tube	mm (in)	9.52 (3 / 8)	
	Wide tube	mm (in)	15.88 (5 / 8)	
Drain connection			20 A, OD26 mm	
Remote Controller			Optional (RCS-SH80TG)	
Refrigerant tubing kit / Accessories			Optional / —	
Color (Approximate value)			Munsell 10Y9.3 / 0.4, RAL 9010-GL	
DIMENSIONS & WEIGHT			Unit dimensions	Package dimensions
Dimensions	Height	mm (in)	190 (7 - 15 / 32)	266 (10 - 15 / 32)
	Width	mm (in)	1,080 (42 - 17 / 32)	1,183 (46 - 9 / 16)
	Depth	mm (in)	670 (26 - 3 / 8)	789 (31 - 1 / 16)
Net weight		kg (lb)	23 (51)	
Shipping weight		kg (lb)	28 (62)	
Shipping volume		m ³ (cu. ft)	0.248 (8.76)	

DATA SUBJECT TO CHANGE WITHOUT NOTICE.

Rated conditions

Cooling: Indoor air temperature 27 °C DB / 19 °C WB, Outdoor air temperature 35 °C DB

Heating: Indoor air temperature 20 °C DB , Outdoor air temperature 7 °C DB / 6 °C WB

6. Ceiling Mounted Type

Unit specifications (B)

MODEL No.	Indoor Unit		SPW-TR253GH56	
POWER SOURCE			220 - 230 - 240 V / 1 phase / 50Hz	
PERFORMANCE			Cooling	Heating
Capacity	kW		7.3	8.0
	BTU / h		25,000	27,000
Air circulation (Hi / Me / Lo)		m ³ / h	1,080 / 960 / 840	
Moisture removal (High)		Liters / h	3.5	—
ELECTRICAL RATINGS				
Voltage rating		V	220 - 230 - 240	
Available voltage range		V	198 - 264	
Running amperes		A	0.43 - 0.43 - 0.43	0.33 - 0.34 - 0.34
Power input		W	90 - 95 - 100	70 - 75 - 80
Power factor		%	95 - 96 - 97	96 - 96 - 98
Fan motor locked rotor amperes		A	1 - 1 - 1	
FEATURES				
Controls			Microprocessor	
Timer			ON / OFF Timer (Max. 72 hr)	
Fan speeds (Indoor unit)			3 and Automatic control	
Air filter			Washable, easy access, long life (2,500 hr)	
Refrigerant control			Electronic expansion valve	
Operation sound (Hi / Me / Lo)		dB-A	39 / 37 / 34	
Refrigerant tubing connections			Flare type	
Refrigerant tube diameter	Narrow tube	mm (in)	9.52 (3 / 8)*	
	Wide tube	mm (in)	15.88 (5 / 8)	
Drain connection			20 A, OD26 mm	
Remote Controller			Optional (RCS-SH80TG)	
Refrigerant tubing kit / Accessories			Optional / —	
Color (Approximate value)			Munsell 10Y9.3 / 0.4, RAL 9010-GL	
DIMENSIONS & WEIGHT			Unit dimensions	Package dimensions
Dimensions	Height	mm (in)	190 (7 - 15 /32)	266 (10 -15 /32)
	Width	mm (in)	1,300 (51 - 3 /16)	1,403 (55 - 1 / 4)
	Depth	mm (in)	670 (26 - 3 / 8)	789 (31 - 1 /16)
Net weight		kg (lb)	26 (57)	
Shipping weight		kg (lb)	32 (71)	
Shipping volume		m ³ (cu. ft)	0.294 (10.4)	

DATA SUBJECT TO CHANGE WITHOUT NOTICE.

Rated conditions

Cooling: Indoor air temperature 27 °C DB / 19 °C WB, Outdoor air temperature 35 °C DB

Heating: Indoor air temperature 20 °C DB , Outdoor air temperature 7 °C DB / 6 °C WB

* Use the "Tube connector" (accessory part with unit).

6. Ceiling Mounted Type

Unit specifications (C)

MODEL No.	Indoor Unit		SPW-TR363GH56	
POWER SOURCE			220 - 230 - 240 V / 1 phase / 50Hz	
PERFORMANCE			Cooling	Heating
Capacity	kW		10.6	11.4
	BTU / h		36,000	39,000
Air circulation (Hi / Me / Lo)		m ³ / h	1,680 / 1,410 / 1,200	
Moisture removal (High)		Liters / h	4.7	—
ELECTRICAL RATINGS				
Voltage rating		V	220 - 230 - 240	
Available voltage range		V	198 - 264	
Running amperes		A	0.95 - 0.96 - 0.98	0.86 - 0.88 - 0.90
Power input		W	200 - 210 - 220	180 - 190 - 200
Power factor		%	96 - 95 - 94	95 - 94 - 93
Fan motor locked rotor amperes		A	2 - 2 - 2	
FEATURES				
Controls			Microprocessor	
Timer			ON / OFF Timer (Max. 72 hr)	
Fan speeds (Indoor unit)			3 and Automatic control	
Air filter			Washable, easy access, long life (2,500 hr)	
Refrigerant control			Electronic expansion valve	
Operation sound (Hi / Me / Lo)		dB-A	42 / 40 / 35	
Refrigerant tubing connections			Flare type	
Refrigerant tube diameter		Narrow tube mm (in)	9.52 (3 / 8)	
		Wide tube mm (in)	19.05 (3 / 4)	
Drain connection			20 A, OD26 mm	
Remote Controller			Optional (RCS-SH80TG)	
Refrigerant tubing kit / Accessories			Optional / —	
Color (Approximate value)			Munsell 10Y9.3 / 0.4, RAL 9010-GL	
DIMENSIONS & WEIGHT				
Dimensions		Height	mm (in)	240 (9 - 7 / 16)
		Width	mm (in)	1,575 (62)
		Depth	mm (in)	670 (26 - 3 / 8)
Net weight			kg (lb)	38 (84)
Shipping weight			kg (lb)	44 (97)
Shipping volume			m ³ (cu. ft)	0.42 (14.8)

DATA SUBJECT TO CHANGE WITHOUT NOTICE.

Rated conditions

Cooling: Indoor air temperature 27 °C DB / 19 °C WB, Outdoor air temperature 35 °C DB

Heating: Indoor air temperature 20 °C DB , Outdoor air temperature 7 °C DB / 6 °C WB

6. Ceiling Mounted Type

Unit specifications (D)

MODEL No.	Indoor Unit		SPW-TR483GH56	
POWER SOURCE			220 - 230 - 240 V / 1 phase / 50Hz	
PERFORMANCE			Cooling	Heating
Capacity	kW		14.0	16.0
	BTU / h		47,800	54,600
Air circulation (Hi / Me / Lo)	m ³ / h		1,920 / 1,680 / 1,320	
Moisture removal (High)	Liters / h		7.0	—
ELECTRICAL RATINGS				
Voltage rating	V		220 - 230 - 240	
Available voltage range	V		198 – 264	
Running amperes	A		0.95 - 0.96 - 0.98	0.86 - 0.88 - 0.90
Power input	W		200 - 210 - 220	180 - 190 - 200
Power factor	%		96 - 95 - 94	95 - 94 - 93
Fan motor locked rotor amperes	A		2 - 2 - 2	
FEATURES				
Controls	Microprocessor			
Timer	ON / OFF Timer (Max. 72 hr)			
Fan speeds (Indoor unit)	3 and Automatic control			
Air filter	Washable, easy access, long life (2,500 hr)			
Refrigerant control	Electronic expansion valve			
Operation sound (Hi / Me / Lo)	dB-A		44 / 41 / 37	
Refrigerant tubing connections	Flare type			
Refrigerant tube diameter	Narrow tube	mm (in)	9.52 (3 / 8)	
	Wide tube	mm (in)	19.05 (3 / 4)	
Drain connection	20 A, OD26 mm			
Remote Controller	Optional (RCS-SH80TG)			
Refrigerant tubing kit / Accessories	Optional / —			
Color (Approximate value)	Munsell 10Y9.3 / 0.4, RAL 9010-GL			
DIMENSIONS & WEIGHT			Unit dimensions	Package dimensions
Dimensions	Height	mm (in)	240 (9 - 7 / 16)	317 (12 - 15 / 32)
	Width	mm (in)	1,575 (62)	1,678 (66 - 1 / 16)
	Depth	mm (in)	670 (26 - 3 / 8)	789 (31 - 1 / 16)
Net weight	kg (lb)		38 (84)	
Shipping weight	kg (lb)		44 (97)	
Shipping volume	m ³ (cu. ft)		0.42 (14.8)	

DATA SUBJECT TO CHANGE WITHOUT NOTICE.

Rated conditions

Cooling: Indoor air temperature 27 °C DB / 19 °C WB, Outdoor air temperature 35 °C DB

Heating: Indoor air temperature 20 °C DB , Outdoor air temperature 7 °C DB / 6 °C WB

6. Ceiling Mounted Type

6-2. Major component specifications

Indoor unit (A)

MODEL No.		SPW-TR183GH56	
Source		220 - 230 - 240 V / 1 phase / 50 Hz	
Controller P.C.B. Ass'y		CR-X253GH (Microprocessor)	
Fan (Number...diameter)	mm	Centrifugal (3 ... ø 130)	
Fan motor			
Model...Nominal output	W	SR4X-31A3P ... 30 W	
Source		220 - 230 - 240 V / 1 phase / 50 Hz	
No. of pole...r.p.m. (230 V, High)	rpm.	4 ... 1,077	
Coil resistance (Ambient temperature 20 °C)	Ω	BRN – WHT : 191.0 ORG – YEL : 40.0 WHT – VLT : 47.1 YEL – BLK : 96.5 VLT – ORG : 40.0 BLK – PNK : 44.7	
Safety device			
Operating temperature	Open °C	130 ± 8	
	Close °C	(79 ± 15)	
Run capacitor	VAC, μF	440 V, 1.5 μF	
Electronic expansion valve			
Coil		DKV - MOZS582E0	
Coil resistance (at 20 °C)	Ω	ORG – GRY : 46 , YEL – GRY : 46 RED – GRY : 46 , BLK – GRY : 46	
Valve body		IKV-24D12	
Heat exchanger			
Coil		Aluminum plate fin / Copper tube	
Rows...fin pitch	mm	3 ... 1.7	
Face area	m ²	0.138	
Auto louver motor			
Auto louver motor...Rated	V, Hz, W, rpm.	220 – 240 VAC, 50 Hz, 3 W, 2.5 rpm.	
Coil resistance (at 25 °C)	Ω	16.430 Ω ± 8 %	

1

6. Ceiling Mounted Type

Indoor unit (B)

MODEL No.		SPW-TR253GH56	
Source		220 - 230 - 240 V / 1 phase / 50 Hz	
Controller P.C.B. Ass'y		CR-X253GH (Microprocessor)	
Fan (Number...diameter)	mm	Centrifugal (4 ... ø 130)	
Fan motor			
Model...Nominal output	W	SR4X-51A6P ... 50 W	
Source		220 - 230 - 240 V / 1 phase / 50 Hz	
No. of pole...r.p.m. (230 V, High)	rpm.	4 ... 1,172	
Coil resistance (Ambient temperature 20 °C)	Ω	BRN – WHT : 111.0 ORG – YEL : 16.7 WHT – VLT : 35.4 YEL – BLK : 136.6 VLT – ORG : 13.4 BLK – PNK : 23.9	
Safety device			
Operating temperature	Open °C	130 ± 8	
	Close °C	(79 ± 15)	
Run capacitor	VAC, μF	440 V, 1.5 μF	
Electronic expansion valve			
Coil		DKV - MOZS582E0	
Coil resistance (at 20 °C)	Ω	ORG – GRY : 46 , YEL – GRY : 46 RED – GRY : 46 , BLK – GRY : 46	
Valve body		IKV-24D12	
Heat exchanger			
Coil		Aluminum plate fin / Copper tube	
Rows...fin pitch	mm	3 ... 1.7	
Face area	m ²	0.168	
Auto louver motor		MT8 - 3C	
Auto louver motor...Rated	V, Hz, W, rpm.	220 – 240 VAC, 50 Hz, 3 W, 2.5 rpm.	
Coil resistance (at 25 °C)	Ω	16.430 Ω ± 8 %	

6. Ceiling Mounted Type

Indoor unit (C)

MODEL No.		SPW-TR363GH56	
Source		220 - 230 - 240 V / 1 phase / 50 Hz	
Controller P.C.B. Ass'y		CR-X253GH (Microprocessor)	
Fan (Number...diameter)	mm	Centrifugal (4 ... ø 150)	
Fan motor			
Model...Nominal output	W	KFG4X-101C6P...100 W	
Source		220 - 230 - 240 V / 1 phase / 50 Hz	
No. of pole...r.p.m. (230 V, High)	rpm.	4...1,015	
Coil resistance (Ambient temperature 20 °C)	Ω	BRN – WHT : 61.05 ORG – YEL : 13.23 WHT – VLT : 9.955 YEL – BLK : 19.25 VLT – ORG : 9.576 BLK – PNK : 10.81	
Safety device			
Operating temperature	Open °C	130 ± 8	
	Close °C	(79 ± 15)	
Run capacitor	VAC, μF	440 V, 4.0 μF	
Electronic expansion valve			
Coil		EKV - MOZS584E0	
Coil resistance (at 20 °C)	Ω	ORG – GRY : 46 , YEL – GRY : 46 RED – GRY : 46 , BLK – GRY : 46	
Valve body		HKV - 30D16	
Heat exchanger			
Coil		Aluminum plate fin / Copper tube	
Rows...fin pitch	mm	3 ... 1.7	
Face area	m ²	0.326	
Auto louver motor			
Auto louver motor...Rated	V, Hz, W, rpm.	220 – 240 VAC, 50 Hz, 3 W, 2.5 rpm.	
Coil resistance (at 25 °C)	Ω	16.430 Ω ± 8 %	

1

6. Ceiling Mounted Type

Indoor unit (D)

MODEL No.		SPW-TR483GH56	
Source		220 - 230 - 240 V / 1 phase / 50Hz	
Controller P.C.B. Ass'y		CR-X253GH (Microprocessor)	
Fan (Number...diameter)	mm	Centrifugal (4...ø150)	
Fan motor			
Model...Nominal output	W	KFG4X-101C6P...100 W	
Source		220 - 230 - 240 V / 1 phase / 50 Hz	
No. of pole...r.p.m. (230 V, High)	rpm.	4...1,070	
Coil resistance (Ambient temperature 20°C)	Ω	BRN – WHT : 61.05 ORG – YEL : 13.23 WHT – VLT : 9.955 YEL – BLK : 19.25 VLT – ORG : 9.576 BLK – PNK : 10.81	
Safety device			
Operating temperature	Open °C	130 ± 8	
	Close °C	(79 ± 15)	
Run capacitor	VAC, μF	440 V, 5.0 μF	
Electronic expansion valve			
Coil		EKV - MOZS584E0	
Coil resistance (at 20°C)	Ω	ORG – GRY : 46 , YEL – GRY : 46 RED – GRY : 46 , BLK – GRY : 46	
Valve body		HKV - 30D16	
Heat exchanger			
Coil		Aluminum plate fin / Copper tube	
Rows...fin pitch	mm	3...1.7	
Face area	m ²	0.326	
Auto louver motor			
Auto louver motor...Rated	V, Hz, W, rpm.	220 – 240 VAC, 50Hz, 3 W, 2.5 rpm.	
Coil resistance (at 25°C)	Ω	16.430 Ω ± 8 %	

6. Ceiling Mounted Type

6-3. Other component specifications

MODEL NO.	Indoor Unit	SPW-TR183 ~ 483GH56	
Power Transformer		ATR-II215TB	
Rated			
Primary	V, Hz	AC 230 V, 50 Hz	
Secondary		10.2 V 1.4 A	
		14 V 0.5 A	
Coil resistance	Ω	WHT –WHT : 112 , BRN – BRN : 0.5 RED – RED : 2.3	
Thermal cut off temperature	$^{\circ}\text{C}$	150	
Thermistor (Coil sensor)		PBC-41E-S14 , PBC-41E-S25	
Resistance	$\text{K}\Omega$	-10 $^{\circ}\text{C}$: 23.7 \pm 5 % , 20 $^{\circ}\text{C}$: 6.5 \pm 5 % -5 $^{\circ}\text{C}$: 18.8 \pm 5 % , 30 $^{\circ}\text{C}$: 4.4 \pm 5 % 0 $^{\circ}\text{C}$: 15.0 \pm 5 % , 40 $^{\circ}\text{C}$: 3.1 \pm 5 % 5 $^{\circ}\text{C}$: 12.1 \pm 5 % , 45 $^{\circ}\text{C}$: 2.6 \pm 5 % 10 $^{\circ}\text{C}$: 9.7 \pm 5 %	
Thermistor (Room or coil sensor)		KTEC-35-S6	
Resistance	$\text{K}\Omega$	0 $^{\circ}\text{C}$: 16.5 \pm 5 % , 40 $^{\circ}\text{C}$: 2.7 \pm 5 % 5 $^{\circ}\text{C}$: 12.8 \pm 5 % , 45 $^{\circ}\text{C}$: 2.2 \pm 5 % 10 $^{\circ}\text{C}$: 10.0 \pm 5 % , 50 $^{\circ}\text{C}$: 1.8 \pm 5 % 20 $^{\circ}\text{C}$: 6.3 \pm 5 % , 55 $^{\circ}\text{C}$: 1.5 \pm 5 % 30 $^{\circ}\text{C}$: 4.0 \pm 5 %	
Electronic expansion valve			
Valve body		IKV-24D12 (SPW-TR183 · 253GH56) HKV-30D16 (SPW-TR363 · 483GH56)	
Coil		DKV-MOZS582E0 (SPW-TR183 · 253GH56) EKV-MOZS584E0 (SPW-TR363 · 483GH56)	

1

6. Ceiling Mounted Type

6-4. Dimensional data

Indoor unit : 18, 25, 36, 48 Type

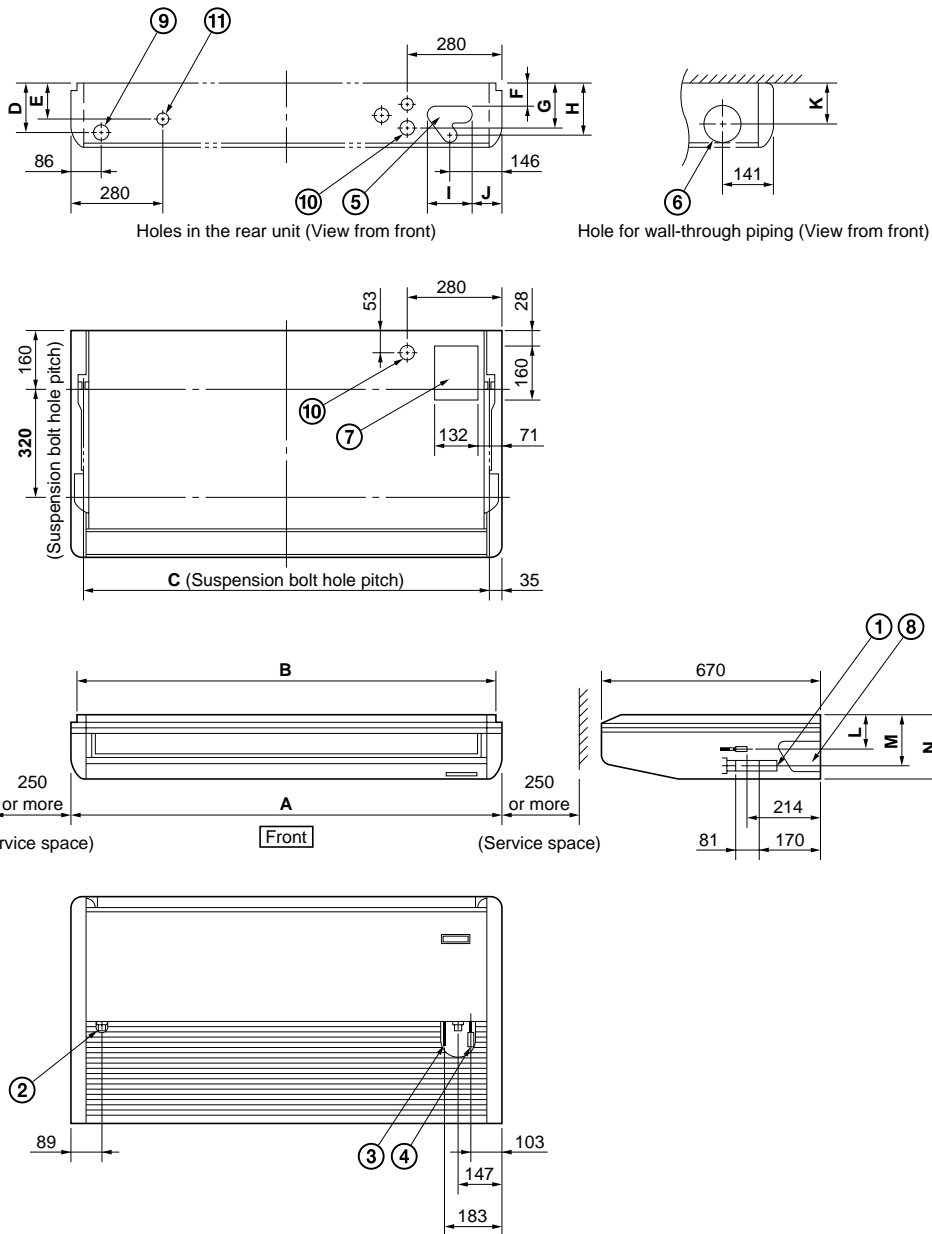

Dimension : mm

- ① Drain connection
- ② Drain connection for left side
- ③ Refrigerant liquid line (ø9.52)
- ④ Refrigerant gas line (18, 25 type: ø15.88 / 36, 48 type: ø19.05)
- ⑤ Hole for rear side refrigerant tubing
- ⑥ Hole for through-the-wall refrigerant tubing (ø100 hole)
- ⑦ Hole for upper side refrigerant tubing (Knockout hole)
- ⑧ Hole for right side refrigerant tubing (Knockout hole)
- ⑨ Hole for left side drain connection (Knockout hole)
- ⑩ Hole for power supply cord (Knockout hole ø40)
- ⑪ Hole for remote controller wiring

	A	B	C	D	E	F	G	H	I	J	K	L	M	N
18 type	1,080	1,060	1,010	147	101	64	134	147	116	83	120	95	147	190
25 type	1,300	1,280	1,230											
36, 48 type	1,575	1,555	1,505											

1238_X_S

6. Ceiling Mounted Type

6-5. Noise criterion curves

MODEL	: SPW-TR183GH56
SOUND LEVEL	: HIGH 36 dB(A), NC 31 LOW 30 dB(A), NC 23
CONDITION	: Distance 1 m, Under the unit 1 m
SOURCE	: 220 - 230 - 240 V, 1 Phase, 50 Hz

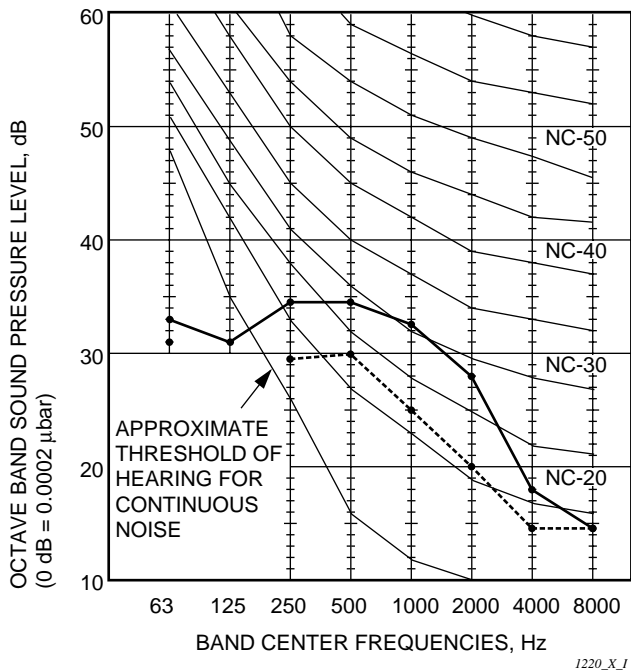

MODEL	: SPW-TR253GH56
SOUND LEVEL	: HIGH 39 dB(A), NC 34 LOW 33 dB(A), NC 26
CONDITION	: Distance 1 m, Under the unit 1 m
SOURCE	: 220 - 230 - 240 V, 1 Phase, 50 Hz

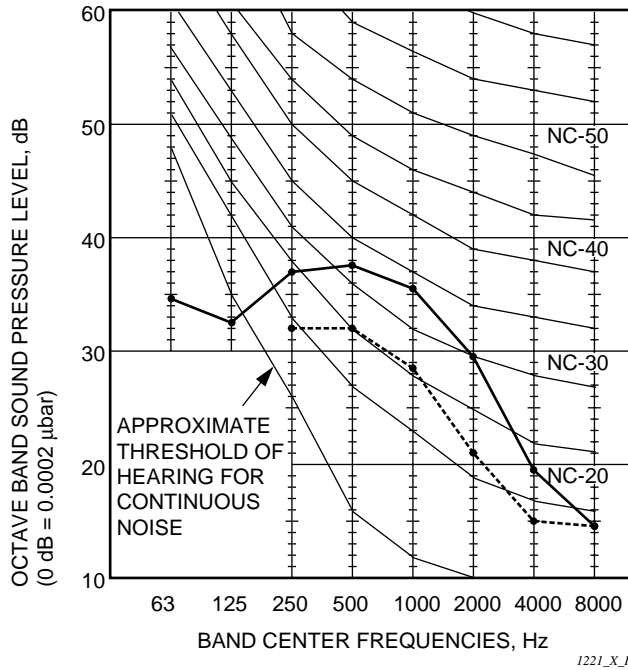

MODEL	: SPW-TR363GH56
SOUND LEVEL	: HIGH 42 dB(A), NC 36 LOW 35 dB(A), NC 28
CONDITION	: Distance 1 m, Under the unit 1 m
SOURCE	: 220 - 230 - 240 V, 1 Phase, 50 Hz

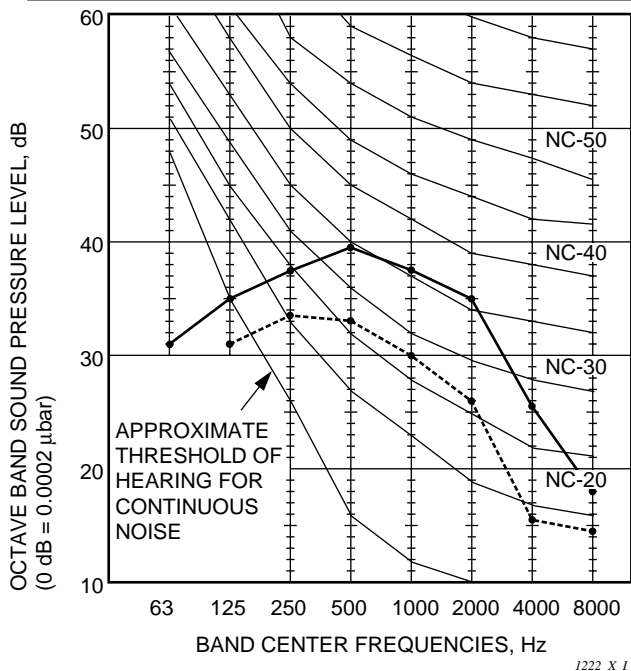

MODEL	: SPW-TR483GH56
SOUND LEVEL	: HIGH 44 dB(A), NC 38 LOW 37 dB(A), NC 31
CONDITION	: Distance 1 m, Under the unit 1 m
SOURCE	: 220 - 230 - 240 V, 1 Phase, 50 Hz

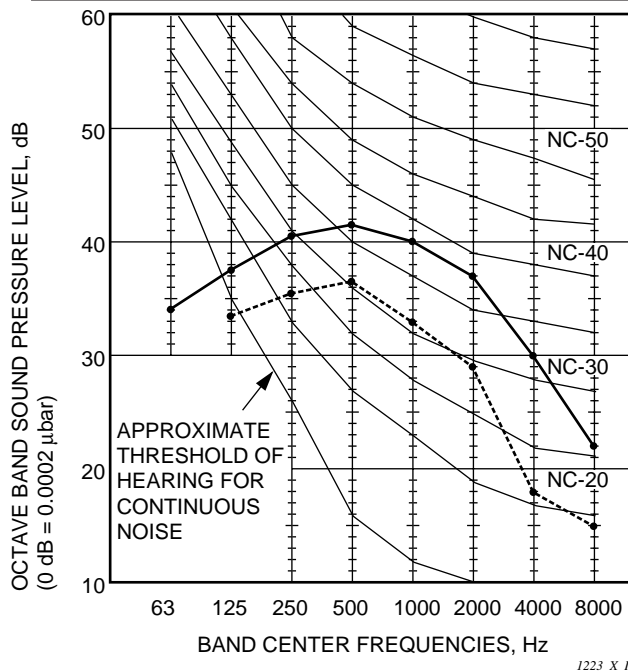

6. Ceiling Mounted Type

6-6. Air throw distance chart



Model: 18 Type

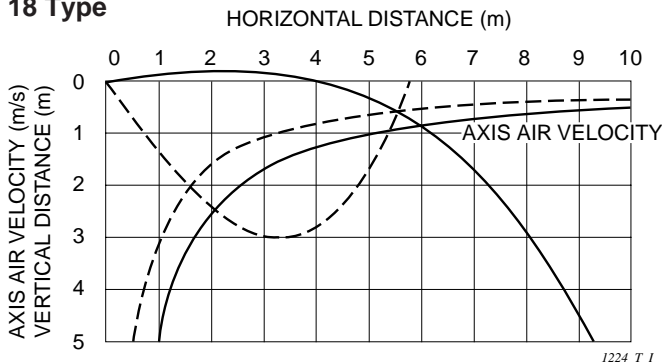

1224_T_I

Model: 25 Type

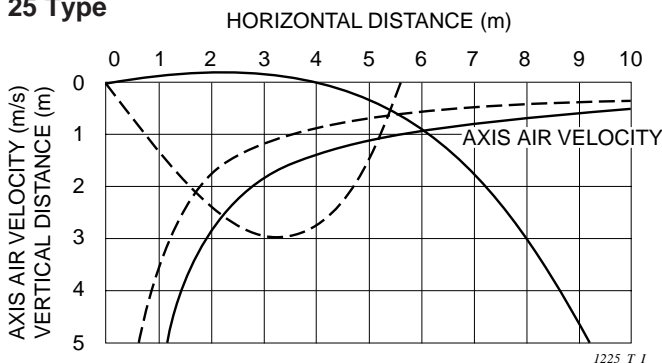

1225_T_I

Model: 36 Type

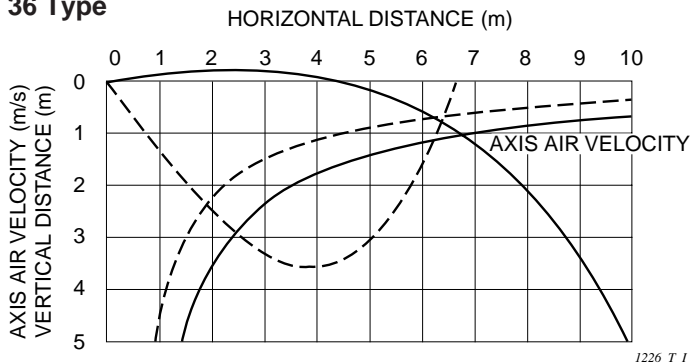

1226_T_I

Model: 48 Type

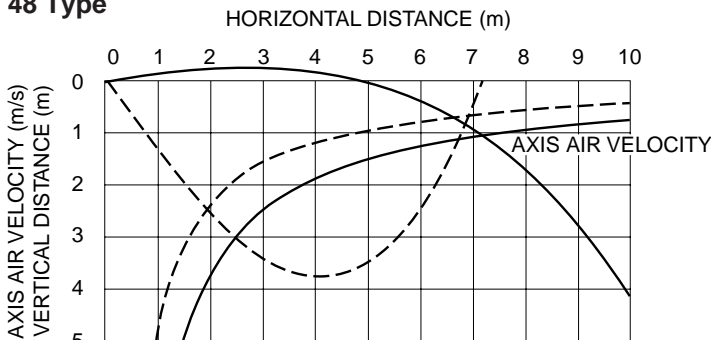

	COOLING	HEATING
FAN SPEED	HIGH	HIGH
ROOM AIR TEMP.	27°	20°
LOUVER ANGLE	-7°	54°

————— : COOLING
 - - - - - : HEATING

1227_T_I

SM830063

7. Concealed Duct Type

7-1. Specifications

Unit specifications (A)

MODEL No.	Indoor Unit		SPW-UR93GH56		
POWER SOURCE			220 - 230 - 240 V / 1 phase / 50Hz		
PERFORMANCE			Cooling	Heating	
Capacity	kW		2.8	3.2	
	BTU / h		9,600	11,000	
Air circulation (Hi / Me / Lo)		m ³ / h	480 / 440 / 330		
Moisture removal (High)		Liters / h	1.3	—	
External static pressure (High)			5 (49): at shipment, 10 (98): using the booster cable		
ELECTRICAL RATINGS					
Voltage rating		V	220 - 230 - 240		
Available voltage range		V	198 - 264		
Running amperes		A	0.37 - 0.4 - 0.43	0.37 - 0.4 - 0.43	
Power input		W	80 - 90 - 100	80 - 90 - 100	
Power factor		%	98.3 - 97.8 - 96.9	98.3 - 97.8 - 96.9	
Max. starting amperes		A	1 - 1 - 1		
FEATURES					
Controls			Microprocessor		
Timer			ON / OFF Timer (Max. 72 hr)		
Fan speeds			3 and Automatic control		
Air filter			Field supply		
Refrigerant control			Electronic expansion valve		
Operation sound (Hi / Me / Lo)		dB-A	30 / 26 / 22		
using the booster cable (Hi / Me / Lo)		dB-A	36 / 33 / 28		
Refrigerant tubing connections			Flare type		
Refrigerant tube		Narrow tube mm (in)	9.52 (3 / 8)		
outer diameter		Wide tube mm (in)	12.7 (1 / 2)		
Drain pump (drain connection)			Max. head 25 cm above drain connection (25A, OD32mm)		
Remote controller (option)			Optional (RCS-SH80TG)		
DIMENSIONS & WEIGHT					
Dimensions		Height	mm (in)	310 (12 - 7 / 32)	380 (14 - 31 / 32)
		Width	mm (in)	750 (29 - 17 / 32)	949 (37 - 12 / 32)
		Depth	mm (in)	665 (26 - 6 / 32)	866 (34 - 3 / 32)
Net weight		kg (lb)		31 (68)	
Shipping weight		kg (lb)		37 (82)	
Shipping volume		m ³ (cu. ft)		0.312 (11)	

DATA SUBJECT TO CHANGE WITHOUT NOTICE.

Cooling :

Rating conditions : Indoor air temperature 27 °C DB / 19 °C WB, Outdoor air temperature 35 °C DB

Heating :

Rating conditions : Indoor air temperature 20 °C DB, Outdoor air temperature 7°C DB / 6°C DB

7. Concealed Duct Type

Unit specifications (B)

MODEL No.	Indoor Unit		SPW-UR123GH56	
POWER SOURCE			220 - 230 - 240 V / 1 phase / 50Hz	
PERFORMANCE			Cooling	Heating
Capacity	kW		3.6	4.2
	BTU / h		12,000	14,000
Air circulation (Hi / Me / Lo)	m ³ / h		600 / 490 / 400	
External static pressure (High)	mmAq (Pa)		5 (49): at shipment, 10 (98): using the booster cable	
Moisture removal (High)	Liters / h		1.8	—
ELECTRICAL RATINGS				
Voltage rating	V		220 - 230 - 240	
Available voltage range	V		198 – 264	
Running amperes	A		0.56 - 0.58 - 0.60	0.56 - 0.58 - 0.60
Power input	W		120 - 130 - 140	120 - 130 - 140
Power factor	%		97 - 97 - 97	97 - 97 - 97
Fan motor locked rotor amperes	A		1 - 1 - 1	
FEATURES				
Controls	Microprocessor			
Timer	ON / OFF Timer (Max. 72 hr)			
Fan speeds	3 and Automatic control			
Air filter	Field supply			
Refrigerant control	Electronic expansion valve			
Operation sound (Hi / Me / Lo)	dB-A		32 / 28 / 23	
using the booster cable (Hi / Me / Lo)	dB-A		37 / 34 / 31	
Refrigerant tubing connections	Flare type			
Refrigerant tube diameter	Narrow tube	mm (in)	9.52 (3 / 8)	
	Wide tube	mm (in)	12.7 (1 / 2)	
Drain connection	25 A, OD32 mm			
Drain pump	Max. head 25 cm above drain connection			
Remote Controller	Optional (RCS-SH80TG)			
Refrigerant tubing kit / Accessories	Optional / Booster cable			
DIMENSIONS & WEIGHT			Unit dimensions	Package dimensions
Dimensions	Height	mm (in)	310 (12 - 1 / 4)	380 (15)
	Width	mm (in)	750 (29 -17 / 32)	949 (37 - 3 / 8)
	Depth	mm (in)	665 (26 - 1 / 4)	866 (34 - 1 / 16)
Net weight	kg (lb)		31 (68)	
Shipping weight	kg (lb)		37 (82)	
Shipping volume	m ³ (cu. ft)		0.312 (11.0)	

DATA SUBJECT TO CHANGE WITHOUT NOTICE.

Rated conditions

Cooling: Indoor air temperature 27 °C DB / 19 °C WB, Outdoor air temperature 35 °C DB

Heating: Indoor air temperature 20 °C DB , Outdoor air temperature 7 °C DB / 6 °C WB

7. Concealed Duct Type

Unit specifications (C)

MODEL No.	Indoor Unit		SPW-UR183GH56	
POWER SOURCE			220 - 230 - 240 V / 1 phase / 50Hz	
PERFORMANCE			Cooling	Heating
Capacity	kW		5.6	6.3
	BTU / h		19,000	21,000
Air circulation (Hi / Me / Lo)	m ³ / h		840 / 680 / 540	
External static pressure (High)	mmAq (Pa)		5 (49): at shipment, 10 (98): using the booster cable	
Moisture removal (High)	Liters / h		2.7	—
ELECTRICAL RATINGS				
Voltage rating	V		220 - 230 - 240	
Available voltage range	V		198 – 264	
Running amperes	A		0.56 - 0.56 - 0.56	0.56 - 0.56 - 0.56
Power input	W		120 - 125 - 130	120 - 125 - 130
Power factor	%		97 - 97 - 97	97 - 97 - 97
Fan motor locked rotor amperes	A		1 - 1 - 1	
FEATURES				
Controls	Microprocessor			
Timer	ON / OFF Timer (Max. 72 hr)			
Fan speeds	3 and Automatic control			
Air filter	Field supply			
Refrigerant control	Electronic expansion valve			
Operation sound (Hi / Me / Lo)	dB-A		34 / 30 / 26	
using the booster cable (Hi / Me / Lo)	dB-A		39 / 36 / 32	
Refrigerant tubing connections	Flare type			
Refrigerant tube diameter	Narrow tube	mm (in)	9.52 (3 / 8)	
	Wide tube	mm (in)	15.88 (5 / 8)	
Drain connection	25 A, OD32 mm			
Drain pump	Max. head 25 cm above drain connection			
Remote Controller	Optional (RCS-SH80TG)			
Refrigerant tubing kit / Accessories	Optional / Booster cable			
DIMENSIONS & WEIGHT				
Dimensions	Height	mm (in)	310 (12 - 1 / 4)	380 (15)
	Width	mm (in)	750 (29 - 17 / 32)	949 (37 - 3 / 8)
	Depth	mm (in)	665 (26 - 1 / 4)	866 (34 - 1 / 16)
Net weight	kg (lb)		32 (71)	
Shipping weight	kg (lb)		38 (84)	
Shipping volume	m ³ (cu. ft)		0.312 (11.0)	

DATA SUBJECT TO CHANGE WITHOUT NOTICE.

Rated conditions

Cooling: Indoor air temperature 27 °C DB / 19 °C WB, Outdoor air temperature 35 °C DB

Heating: Indoor air temperature 20 °C DB , Outdoor air temperature 7 °C DB / 6 °C WB

SM830063

7. Concealed Duct Type

Unit specifications (D)

MODEL No.	Indoor Unit		SPW-UR253GH56	
POWER SOURCE			220 - 230 - 240 V / 1 phase / 50Hz	
PERFORMANCE			Cooling	Heating
Capacity	kW BTU / h		7.3 25,000	8.0 27,000
Air circulation (Hi / Me / Lo)	m ³ / h		1,260 / 1,080 / 780	
External static pressure (High)	mmAq (Pa)		5 (49): at shipment, 10 (98): using the booster cable	
Moisture removal (High)	Liters / h		3.1	—
ELECTRICAL RATINGS				
Voltage rating	V		220 - 230 - 240	
Available voltage range	V		198 - 264	
Running amperes	A		0.84 - 0.89 - 0.90	0.84 - 0.89 - 0.90
Power input	W		180 - 200 - 210	180 - 200 - 210
Power factor	%		97 - 98 - 97	97 - 98 - 97
Fan motor locked rotor amperes	A		1 - 1 - 1	
FEATURES				
Controls			Microprocessor	
Timer			ON / OFF Timer (Max. 72 hr)	
Fan speeds			3 and Automatic control	
Air filter			Field supply	
Refrigerant control			Electronic expansion valve	
Operation sound (Hi / Me / Lo)	dB-A		36 / 31 / 26	
using the booster cable (Hi / Me / Lo)	dB-A		41 / 38 / 35	
Refrigerant tubing connections			Flare type	
Refrigerant tube diameter	Narrow tube	mm (in)	9.52 (3 / 8)*	
	Wide tube	mm (in)	15.88 (5 / 8)	
Drain connection			25 A, OD32 mm	
Drain pump			Max. head 25 cm above drain connection	
Remote Controller			Optional (RCS-SH80TG)	
Refrigerant tubing kit / Accessories			Optional / Booster cable	
DIMENSIONS & WEIGHT			Unit dimensions	Package dimensions
Dimensions	Height	mm (in)	310 (12 - 1 / 4)	380 (15)
	Width	mm (in)	1,050 (41 - 3 / 8)	1,249 (49 - 1 / 4)
	Depth	mm (in)	665 (26 - 1 / 4)	866 (34 - 1 / 16)
Net weight	kg (lb)		41 (90)	
Shipping weight	kg (lb)		50 (110)	
Shipping volume	m ³ (cu. ft)		0.411 (14.5)	

DATA SUBJECT TO CHANGE WITHOUT NOTICE.

Rated conditions

Cooling: Indoor air temperature 27 °C DB / 19 °C WB, Outdoor air temperature 35 °C DB

Heating: Indoor air temperature 20 °C DB , Outdoor air temperature 7 °C DB / 6 °C WB

* Use the "Tube connector" (accessory part with unit).

SM830063

7. Concealed Duct Type

Unit specifications (E)

MODEL No.	Indoor Unit		SPW-UR363GH56	
POWER SOURCE			220 - 230 - 240 V / 1 phase / 50Hz	
PERFORMANCE			Cooling	Heating
Capacity	kW		10.6	11.4
	BTU / h		36,000	39,000
Air circulation (Hi / Me / Lo)	m ³ / h		1,920 / 1,440 / 1,200	
External static pressure (High)	mmAq (Pa)		7 (69): at shipment, 12 (118): using the booster cable	
Moisture removal (High)	Liters / h		3.8	—
ELECTRICAL RATINGS				
Voltage rating	V		220 - 230 - 240	
Available voltage range	V		198 – 264	
Running amperes	A		1.43 - 1.47 - 1.54	1.43 - 1.47 - 1.54
Power input	W		290 - 310 - 340	290 - 310 - 340
Power factor	%		92 - 92 - 92	92 - 92 - 92
Fan motor locked rotor amperes	A		2 - 2 - 2	
FEATURES				
Controls	Microprocessor			
Timer	ON / OFF Timer (Max. 72 hr)			
Fan speeds	3 and Automatic control			
Air filter	Field supply			
Refrigerant control	Electronic expansion valve			
Operation sound (Hi / Me / Lo)	dB-A		42 / 36 / 30	
using the booster cable (Hi / Me / Lo)	dB-A		46 / 42 / 38	
Refrigerant tubing connections	Flare type			
Refrigerant tube diameter	Narrow tube	mm (in)	9.52 (3 / 8)	
	Wide tube	mm (in)	19.05 (3 / 4)	
Drain connection	25 A, OD32 mm			
Drain pump	Max. head 25 cm above drain connection			
Remote Controller	Optional (RCS-SH80TG)			
Refrigerant tubing kit / Accessories	Optional / Booster cable			
DIMENSIONS & WEIGHT				
Dimensions	Height	mm (in)	310 (12 - 1 / 4)	380 (15)
	Width	mm (in)	1,480 (58 - 1 / 4)	1,679 (66 - 3 / 32)
	Depth	mm (in)	665 (26 - 1 / 4)	866 (34 - 1 / 4)
Net weight	kg (lb)		64 (141)	
Shipping weight	kg (lb)		71 (157)	
Shipping volume	m ³ (cu. ft)		0.55 (19.5)	

DATA SUBJECT TO CHANGE WITHOUT NOTICE.

Rated conditions

Cooling: Indoor air temperature 27 °C DB / 19 °C WB, Outdoor air temperature 35 °C DB

Heating: Indoor air temperature 20 °C DB , Outdoor air temperature 7 °C DB / 6 °C WB

SM830063

7. Concealed Duct Type

Unit specifications (F)

MODEL No.	Indoor Unit		SPW-UR483GH56	
POWER SOURCE			220 - 230 - 240 V / 1 phase / 50Hz	
PERFORMANCE			Cooling	Heating
Capacity	kW BTU / h		14.0 47,800	16.0 54,600
Air circulation (Hi / Me / Lo)	m ³ / h		1,920 / 1,440 / 1,200	
External static pressure (High)	mmAq (Pa)		7 (69): at shipment, 12 (118): using the booster cable	
Moisture removal (High)	Liters / h		6.7	—
ELECTRICAL RATINGS				
Voltage rating	V		220 - 230 - 240	
Available voltage range	V		198 – 264	
Running amperes	A		1.48 - 1.51 - 1.58	1.48 - 1.51 - 1.58
Power input	W		310 - 330 - 360	310 - 330 - 360
Power factor	%		95 - 95 - 95	95 - 95 - 95
Fan motor locked rotor amperes	A		2 - 2 - 2	
FEATURES				
Controls			Microprocessor	
Timer			ON / OFF Timer (Max. 72 hr)	
Fan speeds			3 and Automatic control	
Air filter			Field supply	
Refrigerant control			Electronic expansion valve	
Operation sound (Hi / Me / Lo)	dB-A		42 / 36 / 30	
using the booster cable (Hi / Me / Lo)	dB-A		46 / 42 / 38	
Refrigerant tubing connections			Flare type	
Refrigerant tube diameter	Narrow tube mm (in)		9.52 (3 / 8)	
	Wide tube mm (in)		19.05 (3 / 4)	
Drain connection			25 A, OD32 mm	
Drain pump			Max. head 25 cm above drain connection	
Remote Controller			Optional (RCS-SH80TG)	
Refrigerant tubing kit / Accessories			Optional / Booster cable	
DIMENSIONS & WEIGHT			Unit dimensions	Package dimensions
Dimensions	Height	mm (in)	310 (12 - 1 / 4)	380 (15)
	Width	mm (in)	1,480 (58 - 1 / 4)	1,679 (66 - 1 / 4)
	Depth	mm (in)	665 (26 - 1 / 4)	866 (34 - 1 / 4)
Net weight	kg (lb)		64 (141)	
Shipping weight	kg (lb)		71 (157)	
Shipping volume	m ³ (cu. ft)		0.55 (19.5)	

DATA SUBJECT TO CHANGE WITHOUT NOTICE.

Rated conditions

Cooling: Indoor air temperature 27 °C DB / 19 °C WB, Outdoor air temperature 35 °C DB

Heating: Indoor air temperature 20 °C DB , Outdoor air temperature 7 °C DB / 6 °C WB

7. Concealed Duct Type

7-2. Major component specifications

Indoor unit (A)

MODEL No.		SPW-UR93GH56	
Source		220 - 230 - 240 V / 1 phase / 50Hz	
Controller P.C.B. Ass'y		CR-X253GH (Microprocessor)	
Fan (Number...diameter)	mm	Centrifugal (1 ... ø 190)	
Fan motor			
Model...Nominal output	W	KFG4X-31A3P ... 30 W	
Source		220 - 230 - 240 V / 1 phase / 50 Hz	
No. of pole...r.p.m. (230 V, High)	rpm.	4 ... 834	
Coil resistance (Ambient temperature 20°C)	Ω	BRN – WHT : 101.9 WHT – VLT : 17.67 VLT – ORG : 7.86	ORG – YEL : 56.57 YEL – BLK : 366.4 ORG – PNK : 38.84
Safety device			
Operating temperature	Open °C	130 ± 5	
	Close °C	(115 ± 5)	
Run capacitor	VAC, μF	440 V, 2.5 μF	
Electronic expansion valve			
Coil		DKV-MOZS550E0	
Coil resistance (at 20°C)	Ω	ORG – GRY : 46 , RED – GRY : 46 ,	YEL – GRY : 46 BLK – GRY : 46
Valve body		IKV-24D12	
Heat exchanger			
Coil		Aluminum plate fin / Copper tube	
Rows...fin pitch	mm	2 ... 1.5	
Face area	m ²	0.126	
Drain pump		WP20SL-9	
Rated	V, W	AC 230 V, 50 Hz, 14.7 W	
Total head & capacity		400 mm, 600 cc/min	

1

7. Concealed Duct Type

Indoor unit (B)

MODEL No.		SPW-UR123GH56	
Source		220 - 230 - 240 V / 1 phase / 50Hz	
Controller P.C.B. Ass'y		CR-X253GH (Microprocessor)	
Fan (Number...diameter)	mm	Centrifugal (1 ... ø 190)	
Fan motor			
Model...Nominal output	W	KFG4X-71A5P ... 70 W	
Source		220 - 230 - 240 V / 1 phase / 50 Hz	
No. of pole...r.p.m. (230 V, High)	rpm.	4 ... 1,009	
Coil resistance (Ambient temperature 20°C)	Ω	BRN – WHT : 81.1 ORG – YEL : 51.4 WHT – VLT : 12.7 YEL – BLK : 20.6 VLT – ORG : 36.8 VLT – PNK : 44.2	
Safety device			
Operating temperature	Open °C	130 ± 5	
	Close °C	(115 ± 5)	
Run capacitor	VAC, μF	440 V, 4.0 μF	
Electronic expansion valve			
Coil		DKV-MOZS550E0	
Coil resistance (at 20°C)	Ω	ORG – GRY : 46 , YEL – GRY : 46 RED – GRY : 46 , BLK – GRY : 46	
Valve body		IKV-24D12	
Heat exchanger			
Coil		Aluminum plate fin / Copper tube	
Rows...fin pitch	mm	2 ... 1.5	
Face area	m ²	0.126	
Drain pump		WP20SL-9	
Rated	V, W	AC 230 V, 50 Hz, 14.7 W	
Total head & capacity		400 mm, 600 cc/min	

7. Concealed Duct Type

Indoor unit (C)

MODEL No.		SPW-UR183GH56	
Source		220 - 230 - 240 V / 1 phase / 50Hz	
Controller P.C.B. Ass'y		CR-X253GH (Microprocessor)	
Fan (Number...diameter)	mm	Centrifugal (1 ... ø 190)	
Fan motor			
Model...Nominal output	W	KFG4X-101B5P ... 100 W	
Source		220 - 230 - 240 V / 1 phase / 50 Hz	
No. of pole...r.p.m. (230 V, High)	rpm.	4 ... 1,191	
Coil resistance (Ambient temperature 20°C)	Ω	BRN – WHT : 75.8 ORG – YEL : 44.3 WHT – VLT : 18.6 YEL – BLK : 310.5 VLT – ORG : 21.2 ORG – PNK : 42.1	
Safety device			
Operating temperature	Open °C	130 ± 5	
	Close °C	(115 ± 5)	
Run capacitor	VAC, μF	440 V, 4.0 μF	
Electronic expansion valve			
Coil		DKV-MOZS550E0	
Coil resistance (at 20°C)	Ω	ORG – GRY : 46 , YEL – GRY : 46 RED – GRY : 46 , BLK – GRY : 46	
Valve body		IKV-24D12	
Heat exchanger			
Coil		Aluminum plate fin / Copper tube	
Rows...fin pitch	mm	3 ... 1.5	
Face area	m ²	0.126	
Drain pump			
Rated		WP20SL-9	
Rated	V, W	AC 230 V, 50 Hz, 14.7 W	
Total head & capacity		400 mm, 600 cc/min	

1

7. Concealed Duct Type

Indoor unit (D)

MODEL No.		SPW-UR253GH56	
Source		220 - 230 - 240 V / 1 phase / 50Hz	
Controller P.C.B. Ass'y		CR-X253GH (Microprocessor)	
Fan (Number...diameter)	mm	Centrifugal (2 ... ø 190)	
Fan motor			
Model...Nominal output	W	KFC4X-101B5P ... 100 W	
Source		220 - 230 - 240 V / 1 phase / 50 Hz	
No. of pole...r.p.m. (230 V, High)	rpm.	4 ... 1,021	
Coil resistance (Ambient temperature 20°C)	Ω	BRN – WHT : 48.8	ORG – YEL : 37.1
		WHT – VLT : 10.3	YEL – BLK : 90.0
		VLT – ORG : 8.7	ORG – PNK : 30.6
Safety device			
Operating temperature	Open °C	130 ± 5	
	Close °C	(115 ± 5)	
Run capacitor	VAC, μF	440 V, 4.5 μF	
Electronic expansion valve			
Coil		DKV-MOZS550E0	
Coil resistance (at 20°C)	Ω	ORG – GRY : 46 ,	YEL – GRY : 46
		RED – GRY : 46 ,	BLK – GRY : 46
Valve body		IKV-24D12	
Heat exchanger			
Coil		Aluminum plate fin / Copper tube	
Rows...fin pitch	mm	3 ... 1.5	
Face area	m ²	0.202	
Drain pump			
Rated	V, W	AC 230 V, 50 Hz, 14.7 W	
Total head & capacity		400 mm, 600 cc/min	

7. Concealed Duct Type

Indoor unit (E)

MODEL No.		SPW-UR363GH56	
Source		220 - 230 - 240 V / 1 phase / 50Hz	
Controller P.C.B. Ass'y		CR-X253GH (Microprocessor)	
Fan (Number...diameter)	mm	Centrifugal (3 ... ø 190)	
Fan motor			
Model...Nominal output	W	KFG4X-101B5PA...100 W / KFC4X-161B5P...160 W	
Source		220 - 230 - 240 V / 1 phase / 50 Hz	
No. of pole...r.p.m. (230 V, High)	rpm.	4 ... 1,191 / 4 ... 1,191	
Coil resistance (Ambient temperature 20°C)	Ω	BRN – WHT : 75.8 BRN – WHT : 44.4 WHT – VLT : 18.6 WHT – VLT : 9.6 VLT – ORG : 21.2 VLT – ORG : 33.1 ORG – YEL : 44.3 ORG – YEL : 32.0 YEL – BLK : 310.5 YEL – BLK : 74.0 PNK – ORG : 42.1 PNK – ORG : 35.7	
Safety device			
Operating temperature	Open °C	130 ± 5	
	Close °C	(115 ± 5)	
Run capacitor	VAC, μF	440 V, 3.5 μF / 440 V, 6 μF	
Electronic expansion valve			
Coil		EKV-MOZS559E0	
Coil resistance (at 20°C)	Ω	ORG – GRY : 46 , YEL – GRY : 46 RED – GRY : 46 , BLK – GRY : 46	
Valve body		HKV-30D16	
Heat exchanger			
Coil		Aluminum plate fin / Copper tube	
Rows...fin pitch	mm	4 ... 1.5	
Face area	m ²	0.310	
Drain pump		WP20SL-9	
Rated	V, W	AC 230 V, 50 Hz, 14.7 W	
Total head & capacity		400 mm, 600 cc/min	

1

7. Concealed Duct Type

Indoor unit (F)

MODEL No.		SPW-UR483GH56	
Source		220 - 230 - 240 V / 1 phase / 50Hz	
Controller P.C.B. Ass'y		CR-X253GH (Microprocessor)	
Fan (Number...diameter)	mm	Centrifugal (3 ... ø 190)	
Fan motor			
Model...Nominal output	W	KFG4X-101B5PA ... 100 W / KFC4X-161B5P ... 160 W	
Source		220 - 230 - 240 V / 1 phase / 50 Hz	
No. of pole...r.p.m. (230 V, High)	rpm.	4 ... 1,191 / 4 ... 1,191	
Coil resistance (Ambient temperature 20°C)	Ω	BRN – WHT : 75.8 BRN – WHT : 44.4 WHT – VLT : 18.6 WHT – VLT : 9.6 VLT – ORG : 21.2 VLT – ORG : 33.1 ORG – YEL : 44.3 ORG – YEL : 32.0 YEL – BLK : 310.5 YEL – BLK : 74.0 ORG – PNK : 42.1 ORG – PNK : 35.7	
Safety device			
Operating temperature	Open °C	130 ± 5	
	Close °C	(115 ± 5)	
Run capacitor	VAC, μF	440 V, 3.5 μF / 440 V, 6 μF	
Electronic expansion valve			
Coil		EKV-MOZS559E0	
Coil resistance (at 20°C)	Ω	ORG – GRY : 46 , YEL – GRY : 46 RED – GRY : 46 , BLK – GRY : 46	
Valve body		HKV-30D16	
Heat exchanger			
Coil		Aluminum plate fin / Copper tube	
Rows...fin pitch	mm	4 ... 1.5	
Face area	m ²	0.310	
Drain pump			
Rated	V, W	AC 230 V, 50 Hz, 14.7 W	
Total head & capacity		400 mm, 600 cc/min	



7. Concealed Duct Type

7-3. Other component specifications

MODEL NO.	Indoor Unit	SPW-UR93 ~ 483GH56	
Power Transformer		ATR-II215TB	
Rated			
Primary	V, Hz	AC 230 V, 50 Hz	
Secondary		10.2 V 1.4 A	
		14 V 0.5 A	
Coil resistance	Ω	WHT – WHT : 112 , BRN – BRN : 0.5 RED – RED : 2.3	
Thermal cut off temperature	$^{\circ}\text{C}$	150	
Thermistor (Coil sensor)		PBC-41E-S36 , PBC-41E-S25	
Resistance	K Ω	-10 $^{\circ}\text{C}$: 23.7 \pm 5 % , 20 $^{\circ}\text{C}$: 6.5 \pm 5 % -5 $^{\circ}\text{C}$: 18.8 \pm 5 % , 30 $^{\circ}\text{C}$: 4.4 \pm 5 % 0 $^{\circ}\text{C}$: 15.0 \pm 5 % , 40 $^{\circ}\text{C}$: 3.1 \pm 5 % 5 $^{\circ}\text{C}$: 12.1 \pm 5 % , 45 $^{\circ}\text{C}$: 2.6 \pm 5 % 10 $^{\circ}\text{C}$: 9.7 \pm 5 %	
Thermistor (Room or coil sensor)		KTEC-35-S6, KTEC-35-S85	
Resistance	K Ω	0 $^{\circ}\text{C}$: 16.5 \pm 5 % , 40 $^{\circ}\text{C}$: 2.7 \pm 5 % 5 $^{\circ}\text{C}$: 12.8 \pm 5 % , 45 $^{\circ}\text{C}$: 2.2 \pm 5 % 10 $^{\circ}\text{C}$: 10.0 \pm 5 % , 50 $^{\circ}\text{C}$: 1.8 \pm 5 % 20 $^{\circ}\text{C}$: 6.3 \pm 5 % , 55 $^{\circ}\text{C}$: 1.5 \pm 5 % 30 $^{\circ}\text{C}$: 4.0 \pm 5 %	
Electronic expansion valve			
Valve body		IKV-24D12 (SPW-UR93 ~ 253GH56) HKV-30D16 (SPW-UR363 · 483GH56)	
Coil		DKV-MOZS550E0 (SPW-UR93 ~ 253GH56) EKV-MOZS559E0 (SPW-UR363 · 483GH56)	
Drain pump		WP20SL-9	
Rated		AC 230 V, 14.7 W	
Float switch		FS-0218-102	
Rated (Contact rated)		DC 12 V, 25 W	

1

7. Concealed Duct Type

7-4. Dimensional data

Indoor unit : 9, 12, 18 Type

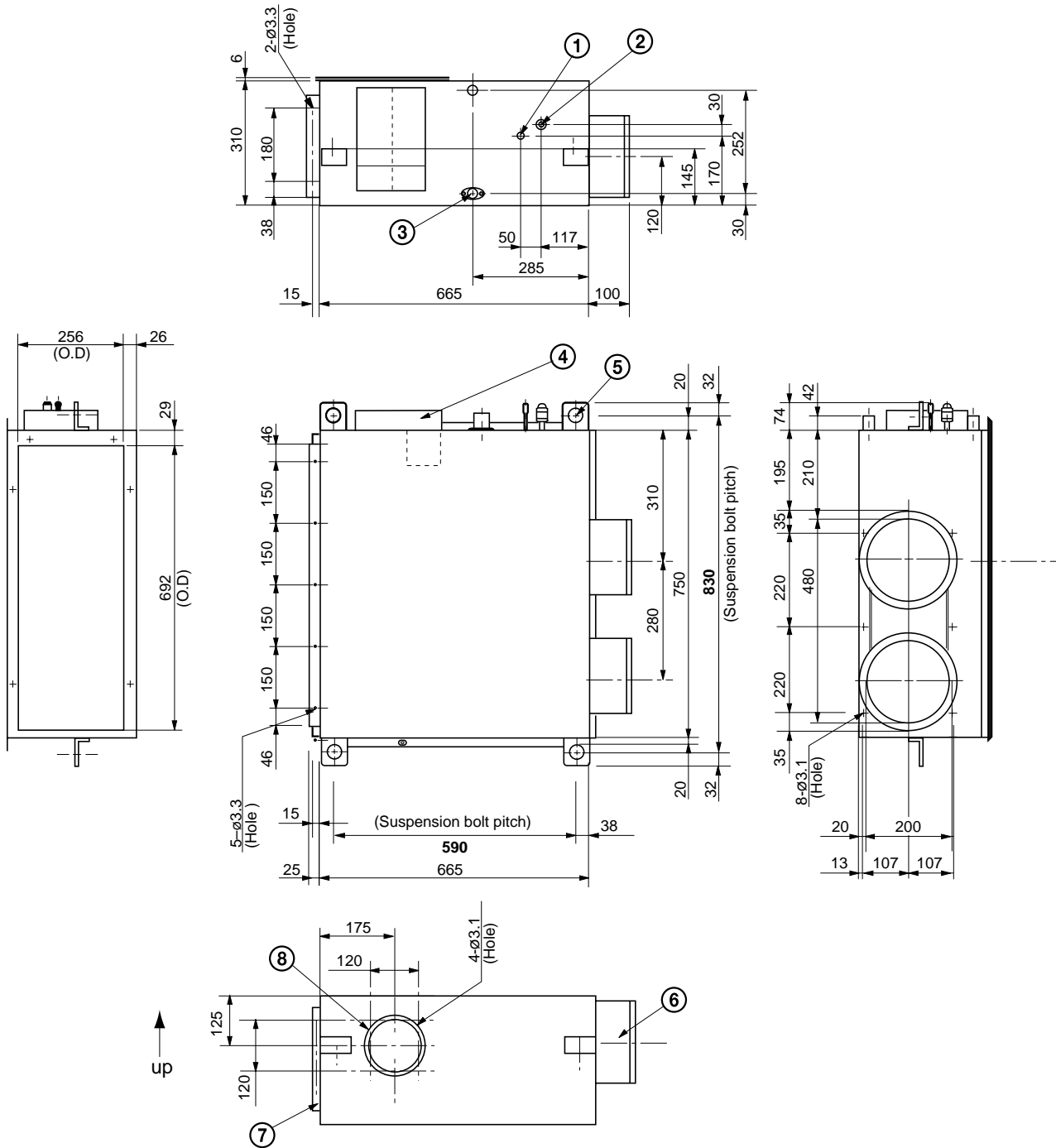

- ① Refrigerant liquid line (ø 9.52)
- ② Refrigerant gas line (9,12: ø 12.7, 18: ø 15.88)
- ③ Drain connection (25 A, O.D.32 mm)
- ④ Electrical junction box
- ⑤ Mounting for suspension
- ⑥ Duct connection for discharge (12: ø 150, 18: ø 200)
- ⑦ Duct connection for suction
- ⑧ Fresh air intake (ø 150)

0867_U_1

7. Concealed Duct Type

Indoor unit: 25 Type

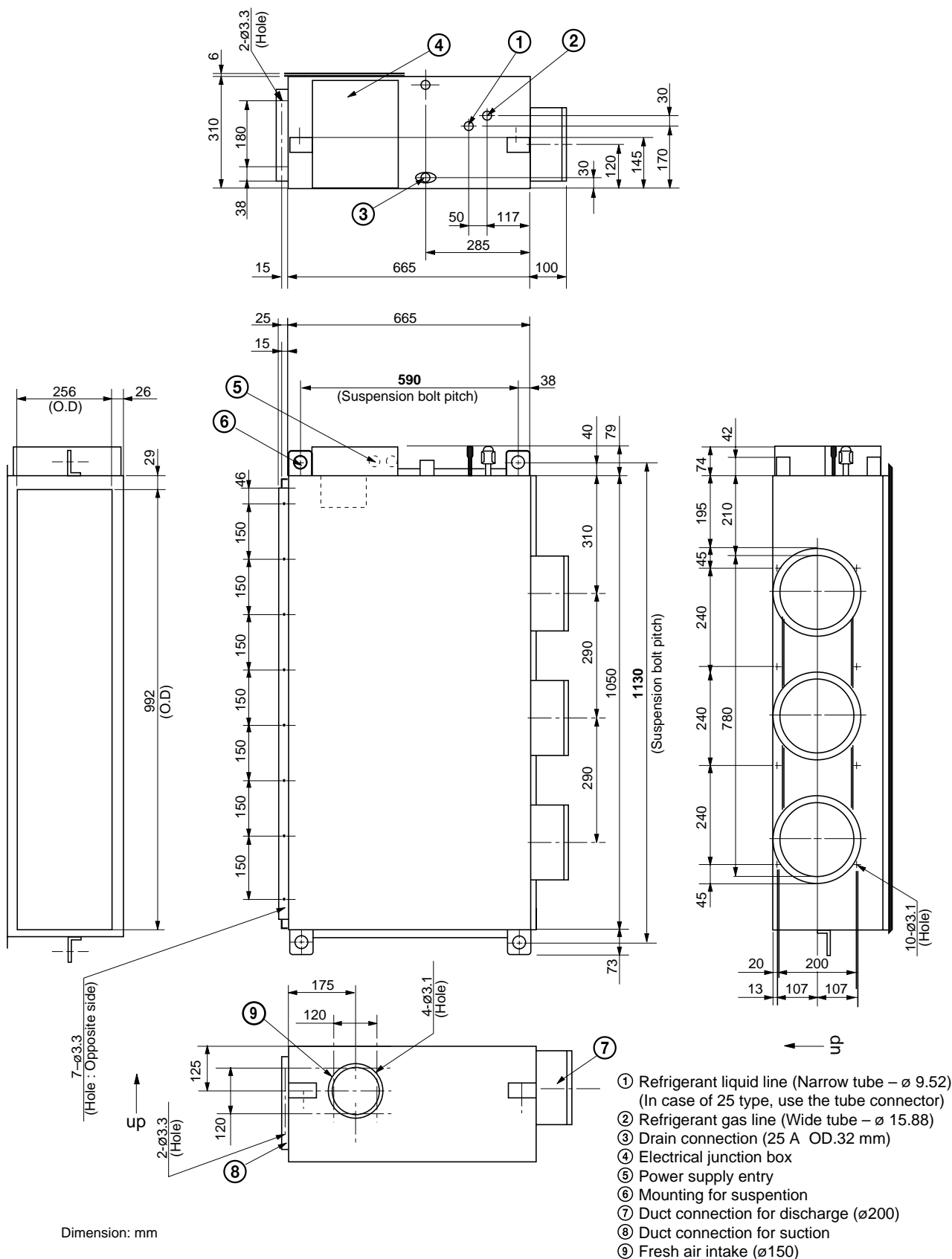

7. Concealed Duct Type

Indoor unit: 36, 48 Type

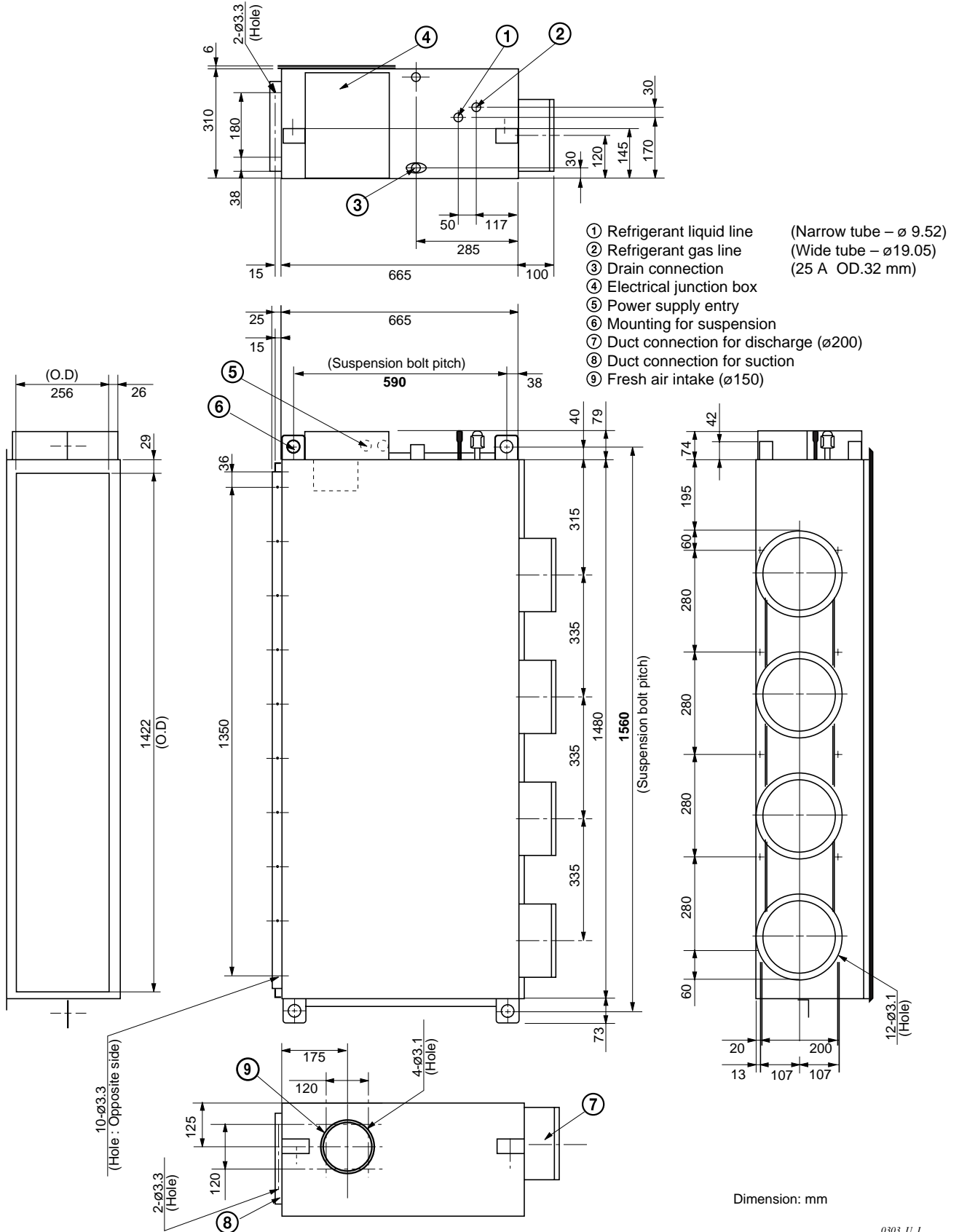

0303_U_1

SM830063

7. Concealed Duct Type

7-5. Noise criterion curves

MODEL : SPW-UR93GH56
 SOUND LEVEL : HIGH 30 dB(A), NC 23 / LOW 22 dB(A), NC 15
 (HIGH 36 dB(A), NC 30 / LOW 28 dB(A), NC 20)
 () : when Booster cable connected
 CONDITION : Under the unit 1.5 m
 SOURCE : 220 - 230 - 240 V, 1 Phase, 50 Hz

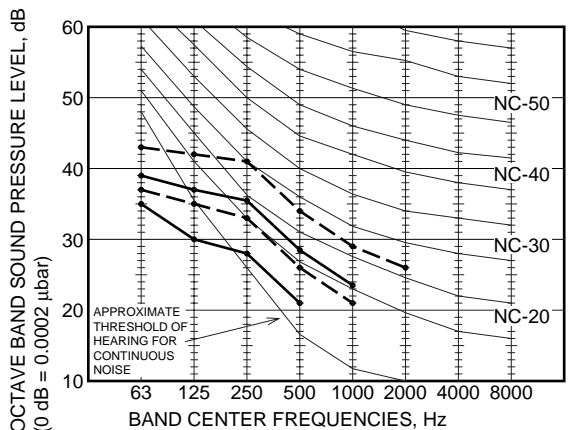

0832_U_1

MODEL : SPW-UR183GH56
 SOUND LEVEL : HIGH 34 dB(A), NC 26 / LOW 26 dB(A), NC 18
 (HIGH 39 dB(A), NC 30 / LOW 32 dB(A), NC 24)
 () : when Booster cable connected
 CONDITION : Under the unit 1.5 m
 SOURCE : 220 - 230 - 240 V, 1 Phase, 50 Hz

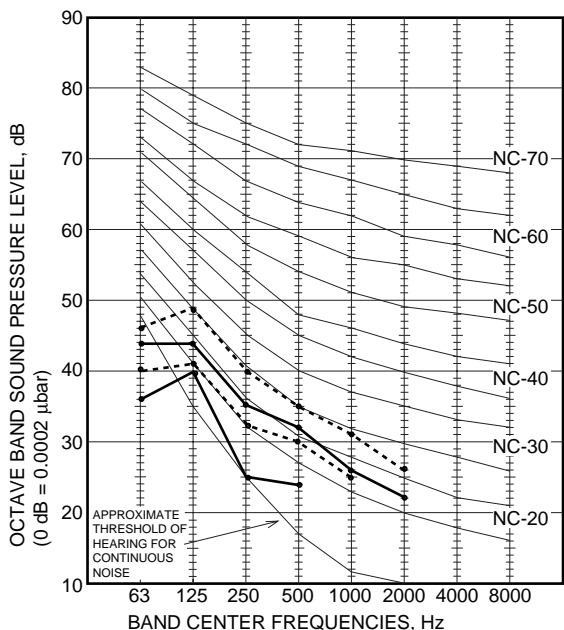

0305_U_1

MODEL : SPW-UR123GH56
 SOUND LEVEL : HIGH 32 dB(A), NC 23 / LOW 23 dB(A), NC 15
 (HIGH 37 dB(A), NC 30 / LOW 31 dB(A), NC 14)
 () : when Booster cable connected
 CONDITION : Under the unit 1.5 m
 SOURCE : 220 - 230 - 240 V, 1 Phase, 50 Hz

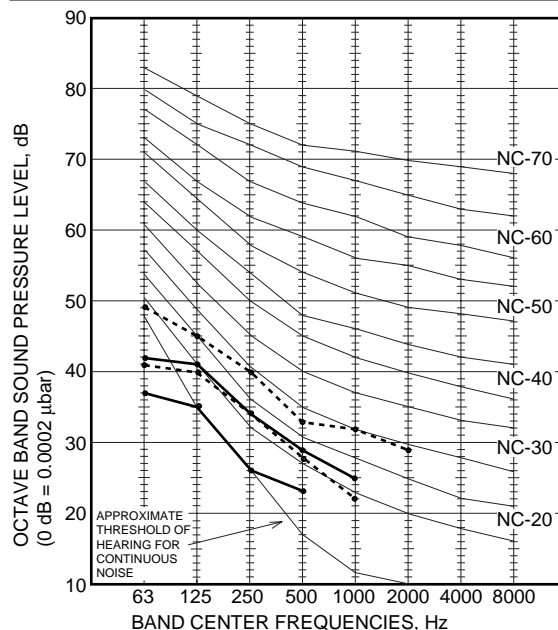

0304_U_1

MODEL : SPW-UR253GH56
 SOUND LEVEL : HIGH 36 dB(A), NC 29 / LOW 26 dB(A), NC 18
 (HIGH 41 dB(A), NC 34 / LOW 35 dB(A), NC 28)
 () : when Booster cable connected
 CONDITION : Under the unit 1.5 m
 SOURCE : 220 - 230 - 240 V, 1 Phase, 50 Hz

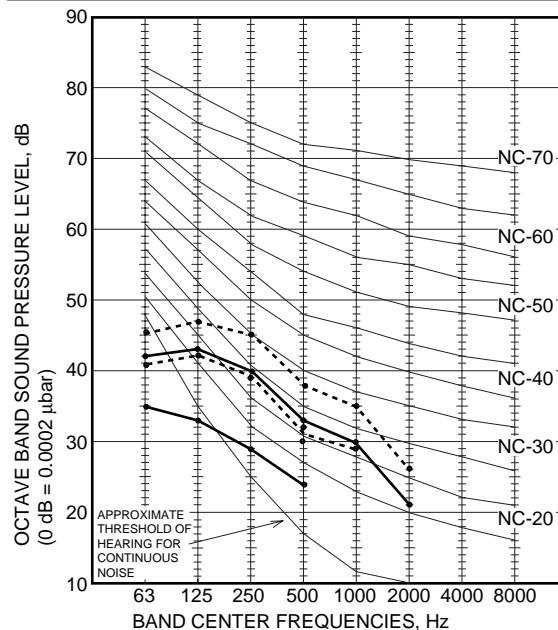

0306_U_1



7. Concealed Duct Type

MODEL : SPW-UR363GH56, UR483GH56
 SOUND LEVEL : HIGH 42 dB(A), NC 37 / LOW 30 dB(A), NC 23
 (HIGH 46 dB(A), NC 41 / LOW 38 dB(A), NC 32)
 () : when Booster cable connected
 CONDITION : Under the unit 1.5 m
 SOURCE : 220 - 230 - 240 V, 1 Phase, 50 Hz

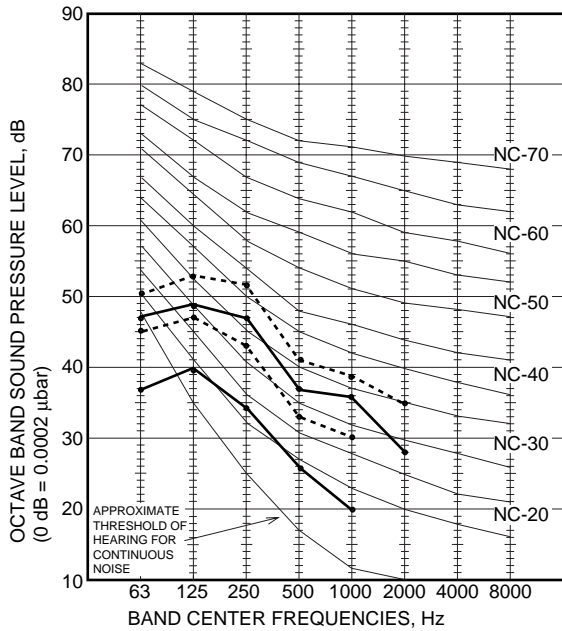

0307_U_1

- REMARKS:**
1. Value obtained in the actual place where the unit is installed may be slightly higher than the values shown in this graph because of the conditions of operation, the structure of the building, the background noise and other factors.
 2. The test results were obtained from an anechoic room.

NOTE

To evaluate "Noise level" the maximum number of the measured OCTAVE BAND SOUND PRESSURE LEVEL is used. Read the number on each BAND CENTER FREQUENCIES (horizontal axis) ranging from 63 Hz to 8000 Hz and select the maximum value (vertical axis) among them.

7. Concealed Duct Type

7-6. Increasing the Fan Speed

If external static pressure is too great (due to long extension of ducts, for example), the air flow volume may drop too low at each air outlet. This problem may be solved by increasing the fan speed using the following procedure:

- (1) Remove 4 screws on the electrical component box and remove the cover plate.
- (2) Disconnect the fan motor sockets in the box.
- (3) Take out the booster cable (sockets at both ends) clamped in the box.
- (4) Securely connect the booster cable sockets between the disconnected fan motor sockets in step 2 as shown.
- (5) Place the cable neatly in the box and reinstall the cover plate.

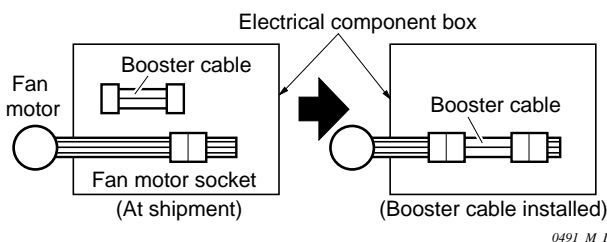

0491_M_I

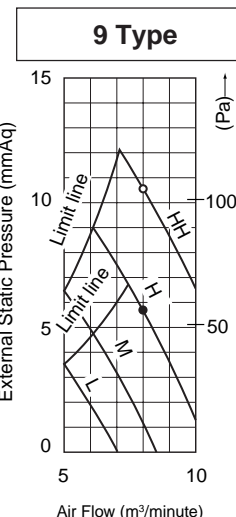

0724_U_I

Indoor Fan Performance

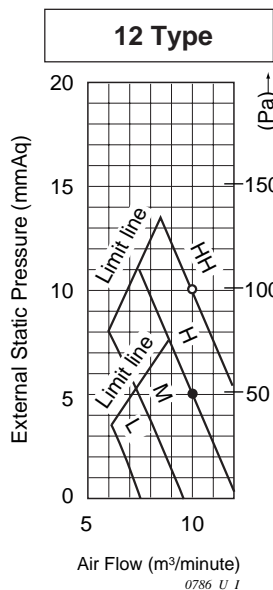

0786_U_I

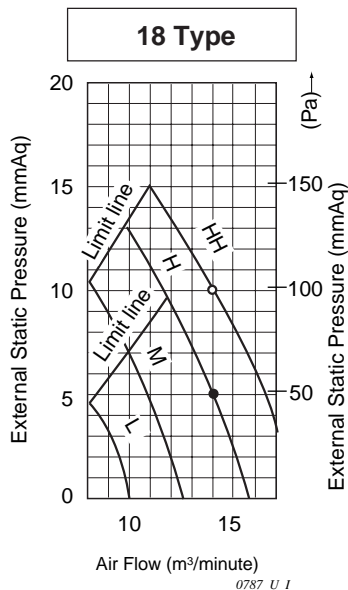

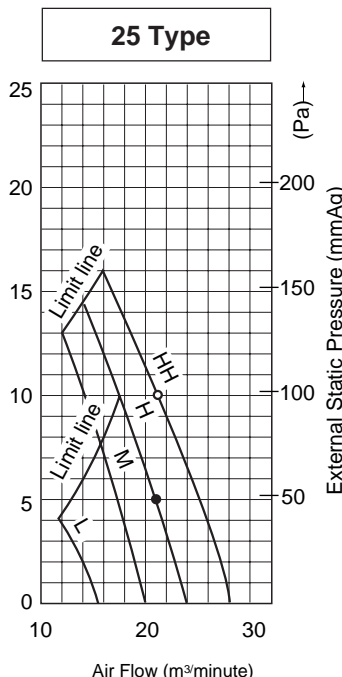

0787_U_I

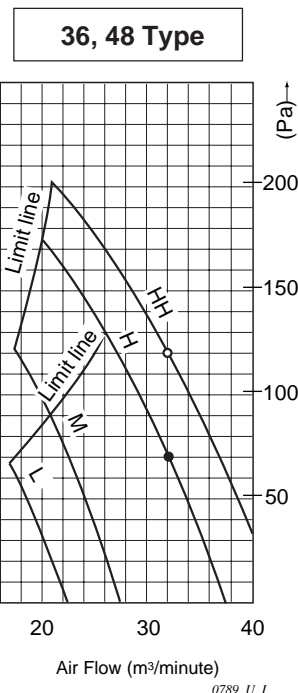

0788_U_I



0789_U_I

NOTE HH : Using the booster cable 
 H : At shipment 

How to read the diagram

The vertical axis is the external static pressure (mmAq) while the horizontal axis represents the AIR FLOW (m³/minute). The characteristic curves for "HH," "H," "Med," and "Low" fan speed control are shown.

The nameplate values are shown based on the "H" air flow. For the 25 type, the air flow is 21 m³/minute, while the external static pressure is 5 mmAq at "H" position. If external static pressure is too great (due to long extension of duct, for example), the air flow volume may drop too low at each air outlet.

This problem may be solved by increasing the fan speed as explained above.

SM830063



8. Concealed Duct High Static Pressure Type

8-1. Specification

Unit specifications (A)

MODEL No.	Indoor Unit		SPW-DR253GH56	
POWER SOURCE			220 - 230 - 240 V / 1 phase / 50Hz	
PERFORMANCE			Cooling	Heating
Capacity	kW BTU / h		7.3 25,000	8.0 27,000
Air circulation (Hi / Me / Lo)	m ³ / h		1,380 / 1,320 / 1,260	
External static pressure (High)	mmAq (Pa)		19 (186)	
Moisture removal (High)	Liters / h		3.1	—
ELECTRICAL RATINGS				
Voltage rating	V		220 - 230 - 240	
Available voltage range	V		198 - 264	
Running amperes	A		2.29 - 2.30 - 2.31	2.29 - 2.30 - 2.31
Power input	W		480 - 505 - 530	480 - 505 - 530
Power factor	%		95 - 95 - 96	95 - 95 - 96
Fan motor locked rotor amperes	A		3 - 3 - 3	
FEATURES				
Controls	Microprocessor			
Timer	ON / OFF Timer (Max. 72 hr)			
Fan speeds	3 and Automatic control			
Air filter	Field supply			
Refrigerant control	Electronic expansion valve			
Operation sound (Hi / Me / Lo)	dB-A		44 / 43 / 42	
Refrigerant tubing connections	Flare type			
Refrigerant tube diameter	Narrow tube	mm (in)	9.52 (3 / 8)*	
	Wide tube	mm (in)	15.88 (5 / 8)	
Drain connection	20 A, OD26 mm			
Remote Controller	Optional (RCS-SH80TG)			
Refrigerant tubing kit / Accessories	Optional / —			
DIMENSIONS & WEIGHT			Unit dimensions	Package dimensions
Dimensions	Height	mm (in)	420 (16 - 1 / 2)	513 (20 - 1 / 4)
	Width	mm (in)	1,065 (41 - 7 / 8)	1,148 (45 - 1 / 4)
	Depth	mm (in)	620 (24 - 3 / 8)	713 (28 - 1 / 8)
Net weight	kg (lb)		47 (104)	
Shipping weight	kg (lb)		61 (134)	
Shipping volume	m ³ (cu. ft)		0.42 (14.8)	

DATA SUBJECT TO CHANGE WITHOUT NOTICE.

Rated conditions

Cooling: Indoor air temperature 27 °C DB / 19 °C WB, Outdoor air temperature 35 °C DB

Heating: Indoor air temperature 20 °C DB , Outdoor air temperature 7 °C DB / 6 °C WB

* Use the "Tube connector" (accessory part with unit).

8. Concealed Duct High Static Pressure Type

Unit specifications (B)

MODEL No.	Indoor Unit		SPW-DR363GH56	
POWER SOURCE			220 - 230 - 240 V / 1 phase / 50Hz	
PERFORMANCE			Cooling	Heating
Capacity	kW		10.6	11.4
	BTU / h		36,000	39,000
Air circulation (Hi / Me / Lo)	m ³ / h		1,800 / 1,680 / 1,500	
External static pressure (High)	mmAq (Pa)		18 (176)	
Moisture removal (High)	Liters / h		4.4	—
ELECTRICAL RATINGS				
Voltage rating	V		220 - 230 - 240	
Available voltage range	V		198 - 264	
Running amperes	A		2.46 - 2.46 - 2.47	2.46 - 2.46 - 2.47
Power input	W		520 - 545 - 570	520 - 545 - 570
Power factor	%		96 - 96 - 96	96 - 96 - 96
Fan motor locked rotor amperes	A		4 - 4 - 4	
FEATURES				
Controls			Microprocessor	
Timer			ON / OFF Timer (Max. 72 hr)	
Fan speeds			3 and Automatic control	
Air filter			Field supply	
Refrigerant control			Electronic expansion valve	
Operation sound (Hi / Me / Lo)	dB-A		45 / 44 / 42	
Refrigerant tubing connections			Flare type	
Refrigerant tube diameter	Narrow tube	mm (in)	9.52 (3 / 8)	
	Wide tube	mm (in)	19.05 (3 / 4)	
Drain connection			20 A, OD26 mm	
Remote Controller			Optional (RCS-SH80TG)	
Refrigerant tubing kit / Accessories			Optional / —	
DIMENSIONS & WEIGHT			Unit dimensions	Package dimensions
Dimensions	Height	mm (in)	420 (16 - 1 / 2)	513 (20 - 1 / 4)
	Width	mm (in)	1,065 (41 - 7 / 8)	1,148 (45 - 1 / 4)
	Depth	mm (in)	620 (24 - 3 / 8)	713 (28 - 1 / 8)
Net weight	kg (lb)		50 (110)	
Shipping weight	kg (lb)		64 (141)	
Shipping volume	m ³ (cu. ft)		0.42 (14.8)	

DATA SUBJECT TO CHANGE WITHOUT NOTICE.

Rated conditions

Cooling: Indoor air temperature 27 °C DB / 19 °C WB, Outdoor air temperature 35 °C DB

Heating: Indoor air temperature 20 °C DB , Outdoor air temperature 7 °C DB / 6 °C WB

8. Concealed Duct High Static Pressure Type

Unit specifications (C)

MODEL No.	Indoor Unit		SPW-DR483GH56	
POWER SOURCE			220 - 230 - 240 V / 1 phase / 50Hz	
PERFORMANCE			Cooling	Heating
Capacity	kW		14.0	16.0
	BTU / h		47,800	54,600
Air circulation (Hi / Me / Lo)		m ³ / h	2,160 / 2,100 / 1,980	
External static pressure (High)		mmAq (Pa)	17 (167)	
Moisture removal (High)		Liters / h	6.6	—
ELECTRICAL RATINGS				
Voltage rating		V	220 - 230 - 240	
Available voltage range		V	198 - 264	
Running amperes		A	2.80 - 2.90 - 3.00	2.80 - 2.90 - 3.00
Power input		W	600 - 660 - 710	600 - 660 - 710
Power factor		%	99 - 99 - 99	99 - 99 - 99
Fan motor locked rotor amperes		A	4 - 4 - 4	
FEATURES				
Controls			Microprocessor	
Timer			ON / OFF Timer (Max. 72 hr)	
Fan speeds			3 and Automatic control	
Air filter			Field supply	
Refrigerant control			Electronic expansion valve	
Operation sound (Hi / Me / Lo)		dB-A	47 / 46 / 44	
Refrigerant tubing connections			Flare type	
Refrigerant tube diameter		Narrow tube mm (in)	9.52 (3 / 8)	
		Wide tube mm (in)	19.05 (3 / 4)	
Drain connection			20 A, OD26 mm	
Remote Controller			Optional (RCS-SH80TG)	
Refrigerant tubing kit / Accessories			Optional / —	
DIMENSIONS & WEIGHT				
Dimensions		Height	mm (in)	450 (17 - 3 / 4)
		Width	mm (in)	1,065 (41 - 7 / 8)
		Depth	mm (in)	620 (24 - 3 / 8)
Net weight			kg (lb)	54 (119)
Shipping weight			kg (lb)	69 (152)
Shipping volume			m ³ (cu. ft)	0.42 (14.8)

DATA SUBJECT TO CHANGE WITHOUT NOTICE.

Rated conditions

Cooling: Indoor air temperature 27 °C DB / 19 °C WB, Outdoor air temperature 35 °C DB

Heating: Indoor air temperature 20 °C DB , Outdoor air temperature 7 °C DB / 6 °C WB

8. Concealed Duct High Static Pressure Type

8-2. Major component specifications

Indoor unit (A)

MODEL No.		SPW-DR253GH56	
Source		220 - 230 - 240 V / 1 phase / 50Hz	
Controller P.C.B. Ass'y		CR-X253GH (Microprocessor)	
Fan (Number...diameter)	mm	Centrifugal (1 ... ø 220)	
Fan motor			
Model...Nominal output	W	KFC4X-201B5P ... 200 W	
Source		220 - 230 - 240 V / 1 phase / 50 Hz	
No. of pole...r.p.m. (230 V, High)	rpm.	4 ... 1,004	
Coil resistance (Ambient temperature 20°C)	Ω	BRN – WHT : 13.75 ORG – YEL : 2.21 WHT – VLT : 4.47 YEL – BLK : 10.33 VLT – ORG : 1.20 BLK – PNK : 12.90	
Safety device			
Operating temperature	Open °C	130 ± 5	
	Close °C	(79 ± 15)	
Run capacitor	VAC, μF	440 V, 5.0 μF	
Electronic expansion valve			
Coil		DKV-MOZS550E0	
Coil resistance (at 20°C)	Ω	ORG – GRY : 46 , YEL – GRY : 46 RED – GRY : 46 , BLK – GRY : 46	
Valve body		IKV-24D12	
Heat exchanger			
Coil		Aluminum plate fin / Copper tube	
Rows...fin pitch	mm	3 ... 2.0	
Face area	m ²	0.233	

1

8. Concealed Duct High Static Pressure Type

Indoor unit (B)

MODEL No.		SPW-DR363GH56	
Source		220 - 230 - 240 V / 1 phase / 50Hz	
Controller P.C.B. Ass'y		CR-X253GH (Microprocessor)	
Fan (Number...diameter)	mm	Centrifugal (1 ... ø 220)	
Fan motor			
Model...Nominal output	W	KFC4X-201B5P ... 200 W	
Source		220 - 230 - 240 V / 1 phase / 50 Hz	
No. of pole...r.p.m. (230 V, High)	rpm.	4 ... 1,134	
Coil resistance (Ambient temperature 20°C)	Ω	BRN – WHT : 13.75 ORG – YEL : 2.21 WHT – VLT : 4.47 YEL – BLK : 10.33 VLT – ORG : 1.20 BLK – PNK : 12.90	
Safety device			
Operating temperature	Open °C	130 ± 5	
	Close °C	(79 ± 15)	
Run capacitor	VAC, μF	440 V, 7.0 μF	
Electronic expansion valve			
Coil		EKV-MOZS559E0	
Coil resistance (at 20°C)	Ω	ORG – GRY : 46 , YEL – GRY : 46 RED – GRY : 46 , BLK – GRY : 46	
Valve body		HKV-30D16	
Heat exchanger			
Coil		Aluminum plate fin / Copper tube	
Rows...fin pitch	mm	4 ... 2.0	
Face area	m ²	0.273	

8. Concealed Duct High Static Pressure Type

Indoor unit (C)

MODEL No.		SPW-DR483GH56	
Source		220 - 230 - 240 V / 1 phase / 50Hz	
Controller P.C.B. Ass'y		CR-X253GH (Microprocessor)	
Fan (Number...diameter)	mm	Centrifugal (1 ... ø 250)	
Fan motor			
Model...Nominal output	W	KFC4Q-401A5P ... 400 W	
Source		220 - 230 - 240 V / 1 phase / 50 Hz	
No. of pole...r.p.m. (230 V, High)	rpm.	4 ... 1,077	
Coil resistance (Ambient temperature 20°C)	Ω	BRN – WHT : 11.05 ORG – YEL : 4.57 WHT – VLT : 1.80 YEL – PNK : 7.70 VLT – ORG : 1.00	
Safety device			
Operating temperature	Open °C	130 ± 5	
	Close °C	(79 ± 15)	
Run capacitor	VAC, μF	440 V, 7 μF x 2	
Electronic expansion valve			
Coil		EKV-MOZS559E0	
Coil resistance (at 20°C)	Ω	ORG – GRY : 46 , YEL – GRY : 46 RED – GRY : 46 , BLK – GRY : 46	
Valve body		HKV-30D16	
Heat exchanger			
Coil		Aluminum plate fin / Copper tube	
Rows...fin pitch	mm	4 ... 2.0	
Face area	m ²	0.273	

1

8. Concealed Duct High Static Pressure Type

8-3. Other component specifications

MODEL NO.	Indoor Unit	SPW-DR253 ~ 483GH56	
Power Transformer		ATR-II215TB	
Rated			
Primary	V, Hz	AC 230 V, 50 Hz	
Secondary		10.2 V 1.4 A	
		14 V 0.5 A	
Coil resistance	Ω	WHT – WHT : 112 , BRN – BRN : 0.5 RED – RED : 2.3	
Thermal cut off temperature	$^{\circ}\text{C}$	150	
Thermistor (Coil sensor)		PBC-41E-S36 , PBC-41E-S25	
Resistance	$\text{K}\Omega$	-10 $^{\circ}\text{C}$: 23.7 \pm 5 % , 20 $^{\circ}\text{C}$: 6.5 \pm 5 % -5 $^{\circ}\text{C}$: 18.8 \pm 5 % , 30 $^{\circ}\text{C}$: 4.4 \pm 5 % 0 $^{\circ}\text{C}$: 15.0 \pm 5 % , 40 $^{\circ}\text{C}$: 3.1 \pm 5 % 5 $^{\circ}\text{C}$: 12.1 \pm 5 % , 45 $^{\circ}\text{C}$: 2.6 \pm 5 % 10 $^{\circ}\text{C}$: 9.7 \pm 5 %	
Thermistor (Room or coil sensor)		KTEC-35-S85	
Resistance	$\text{K}\Omega$	0 $^{\circ}\text{C}$: 16.5 \pm 5 % , 40 $^{\circ}\text{C}$: 2.7 \pm 5 % 5 $^{\circ}\text{C}$: 12.8 \pm 5 % , 45 $^{\circ}\text{C}$: 2.2 \pm 5 % 10 $^{\circ}\text{C}$: 10.0 \pm 5 % , 50 $^{\circ}\text{C}$: 1.8 \pm 5 % 20 $^{\circ}\text{C}$: 6.3 \pm 5 % , 55 $^{\circ}\text{C}$: 1.5 \pm 5 % 30 $^{\circ}\text{C}$: 4.0 \pm 5 %	
Electronic expansion valve			
Valve body		IKV-24D12 (SPW-DR253GH56) HKV-30D16 (SPW-DR363 · 483GH56)	
Coil		DKV-MOZS550E0 (SPW-DR253GH56) EKV-MOZS559E0 (SPW-DR363 · 483GH56)	
Float switch		FS-0218-103	
Rated (Contact rated)		DC 12 V, 25 W	

8. Concealed Duct High Static Pressure Type

8-4. Dimensional data

Indoor unit : 25, 36, 48 Type

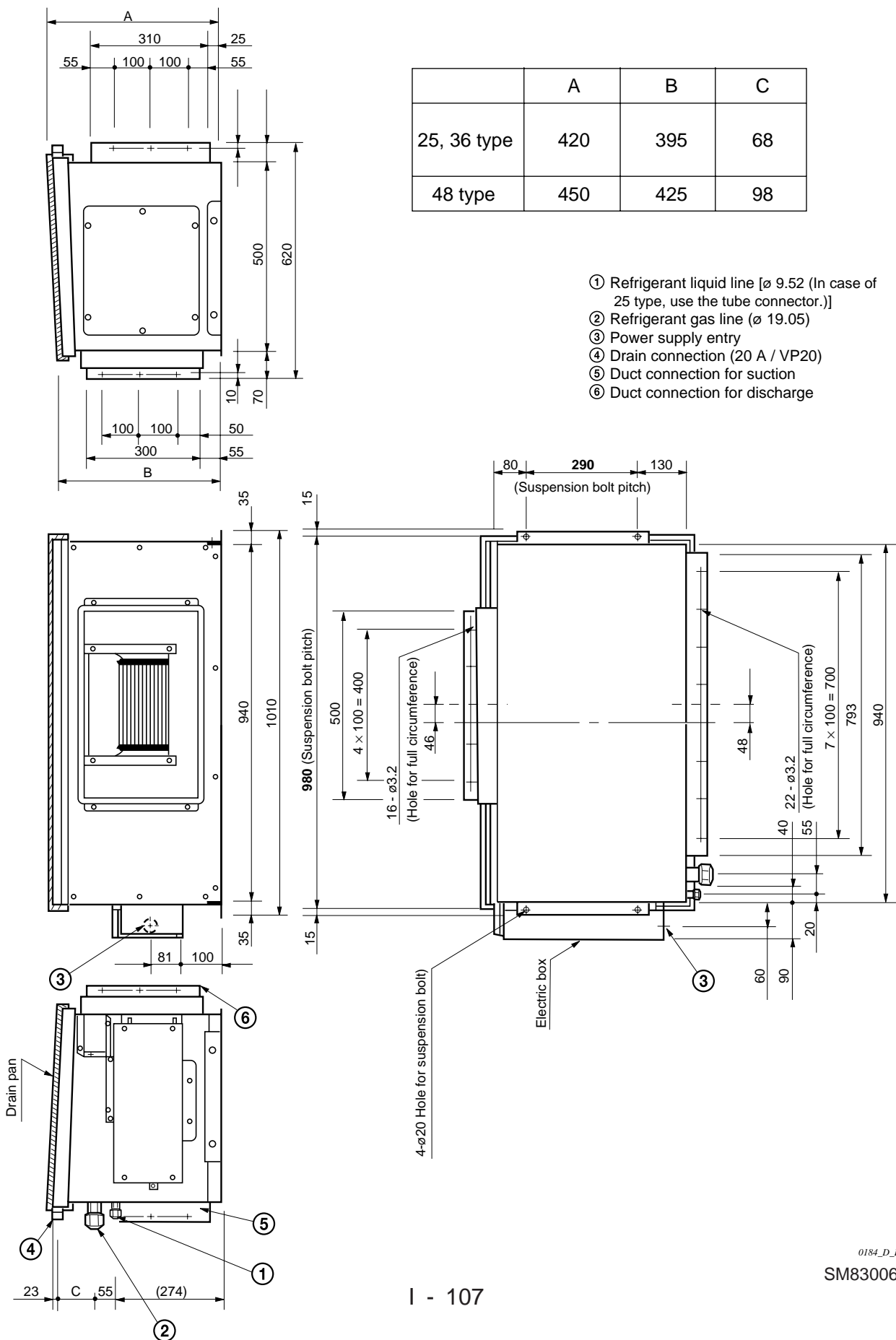

8. Concealed Duct High Static Pressure Type

8-5. Noise criterion curves

MODEL	: SPW-DR253GH56
SOUND LEVEL	: HIGH 44 dB(A), NC 38
CONDITION	: Under the unit 1.5 m
SOURCE	: 220 - 230 - 240 V, 1 Phase, 50 Hz

MODEL	: SPW-DR363GH56
SOUND LEVEL	: HIGH 45 dB(A), NC 39
CONDITION	: Under the unit 1.5 m
SOURCE	: 220 - 230 - 240 V, 1 Phase, 50 Hz

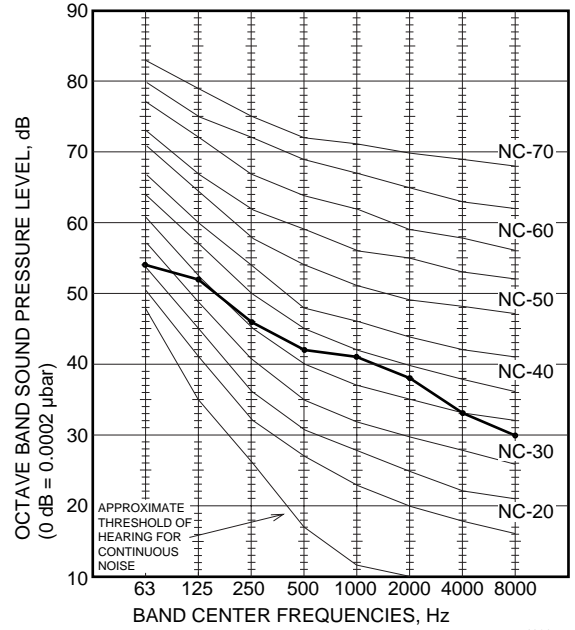
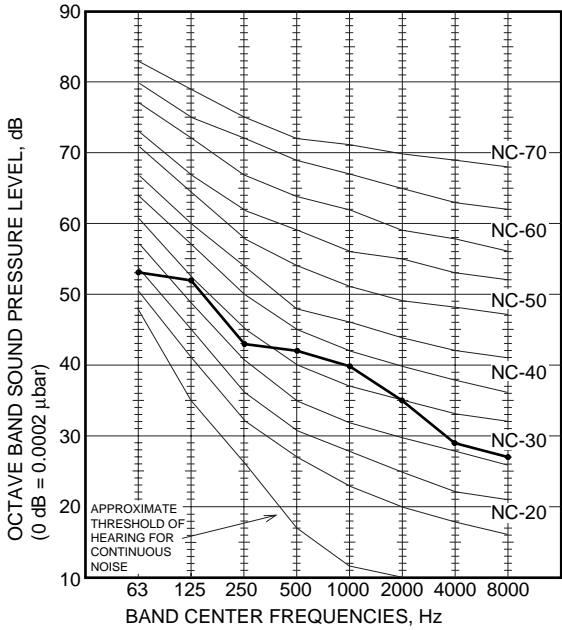

MODEL	: SPW-DR483GH56
SOUND LEVEL	: HIGH 47 dB(A), NC 42
CONDITION	: Under the unit 1.5 m
SOURCE	: 220 - 230 - 240 V, 1 Phase, 50 Hz

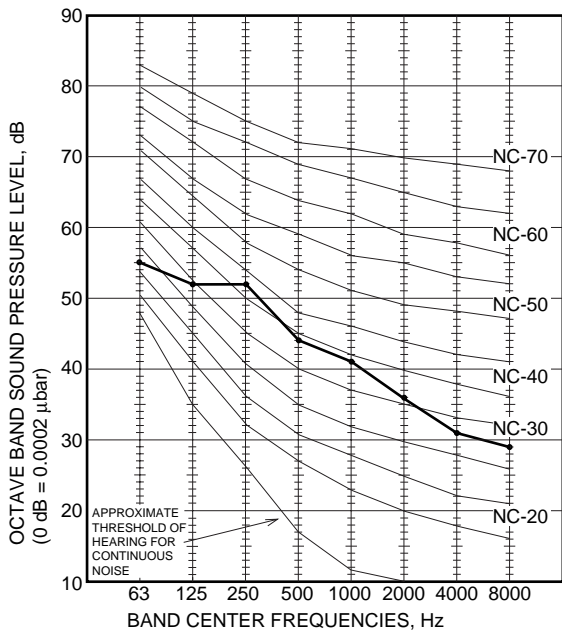

- REMARKS:**
1. Value obtained in the actual place where the unit is installed may be slightly higher than the values shown in this graph because of the conditions of operation, the structure of the building, the background noise and other factors.
 2. The test results were obtained from an anechoic room.

NOTE

To evaluate "Noise level" the maximum number of the measured OCTAVE BAND SOUND PRESSURE LEVEL is used. Read the number on each BAND CENTER FREQUENCIES (horizontal axis) ranging from 63 Hz to 8000 Hz and select the maximum value (vertical axis) among them.

8. Concealed Duct High Static Pressure Type

8-6. Indoor fan performance

How to Read the Diagram

The vertical axis is the EXTERNAL STATIC PRESSURE (mmAq) while the horizontal axis represents the AIR FLOW (m³/minute). The characteristic curve for the "H", "Med", and "Lo" fan speed control.

The name plate values are shown based on the "H" air flow. Therefore in the case of the 25 type the flow is 23 m³/minute, while the EXTERNAL STATIC PRESSURE is 19 mmAq at "H" position. If the external static pressure is too great (due to long extension of duct, for example), the air flow volume may drop too low at each air outlet.



25, 27 Type

36 Type

48 Type

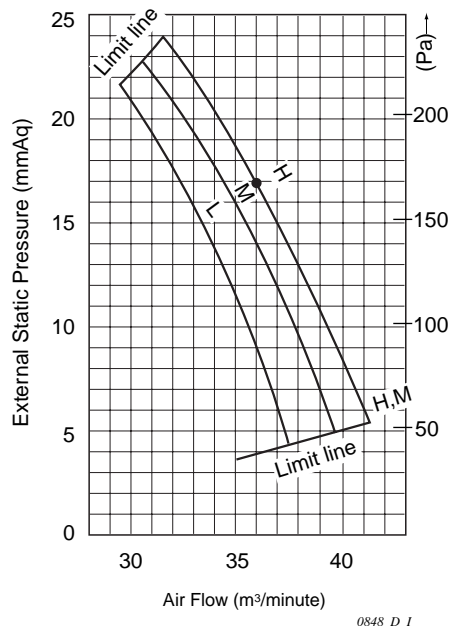
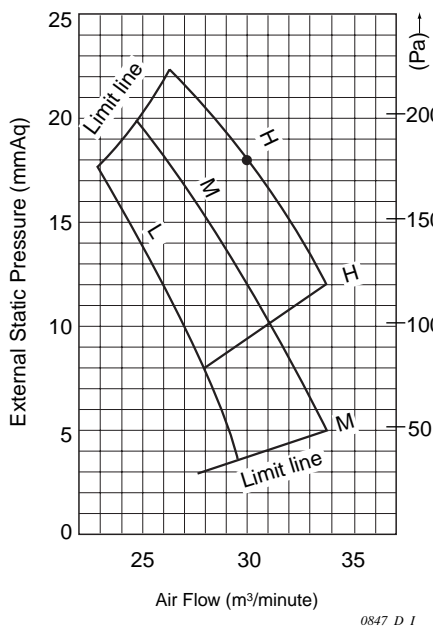
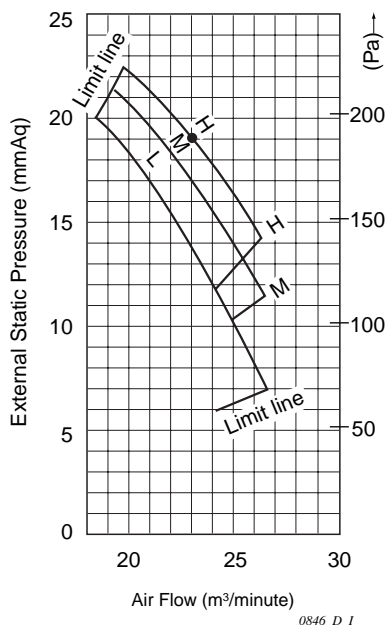

9. Floor-Standing Type (F Type)

9-1. Specifications

Unit specifications (A)

MODEL No.	Indoor Unit		SPW-FR93GH56	
POWER SOURCE			220 - 230 - 240 V / 1 phase / 50Hz	
PERFORMANCE			Cooling	Heating
Capacity	kW		2.8	3.2
	BTU / h		9,600	11,000
Air circulation (Hi / Me / Lo)		m ³ / h	420 / 360 / 300	
Moisture removal (High)		Liters / h	1.3	—
ELECTRICAL RATINGS				
Voltage rating		V	220 - 230 - 240	
Available voltage range		V	198 - 264	
Running amperes*		A	0.24 - 0.25 - 0.26	0.17 - 0.18 - 0.19
Power input		W	51 - 56 - 61	36 - 40 - 45
Power factor		%	96.6 - 97.4 - 97.8	96.3 - 96.6 - 98.7
Max. starting amperes		A	1 - 1 - 1	
FEATURES				
Controls		Microprocessor		
Timer		ON / OFF Timer (Max.72 hr)		
Fan speeds		3 and Automatic control		
Air filter		Washable, easy access		
Refrigerant control		Electronic expansion valve		
Operation sound (Hi / Me / Lo)		dB-A	33 / 30 / 28	
Refrigerant tubing connections		Flare type		
Refrigerant tube outer diameter	Narrow tube	mm (in)	9.52 (3 / 8)	
	Wide tube	mm (in)	12.7 (1 / 2)	
Drain connection		20A, OD26mm		
Drain pump		—		
Drain pump (drain connection)		Optional (RCS-SH80TG)		
Remote controller (option)		Optional / drain hose		
Color (Approximate value)		Munsell 10Y9.3 / 0.4, RAL 9010-GL		
DIMENSIONS & WEIGHT				
Dimensions	Height	mm (in)	615 (24 - 7/32)	694 (27 - 10/32)
	Width	mm (in)	1065 (41 - 30/32)	1157 (45 - 18/32)
	Depth	mm (in)	230 (9 - 2/32)	312 (12 - 9/32)
Net weight		kg (lb)	29 (64)	
Shipping weight		kg (lb)	64 (68)	
Shipping volume		m ³ (cu. ft)	0.251 (8.9)	

DATA SUBJECT TO CHANGE WITHOUT NOTICE.

Cooling :

Rating conditions(★) : Indoor air temperature 27 °C DB / 19 °C WB, Outdoor air temperature 35 °C DB

Heating :

Rating conditions(★) : Indoor air temperature 20 °C DB, Outdoor air temperature 7°C DB / 6°C DB

9. Floor-Standing Type (F Type)

Unit specifications (B)

MODEL No.	Indoor Unit		SPW-FR123GH56	
POWER SOURCE			220 - 230 - 240 V / 1 phase / 50Hz	
PERFORMANCE			Cooling	Heating
Capacity	kW		3.6	4.2
	BTU / h		12,000	14,000
Air circulation (Hi / Me / Lo)		m ³ / h	540 / 420 / 360	
Moisture removal (High)		Liters / h	1.7	—
ELECTRICAL RATINGS				
Voltage rating		V	220 - 230 - 240	
Available voltage range		V	198 - 264	
Running amperes*		A	0.37 - 0.38 - 0.39	0.3 - 0.31 - 0.32
Power input		W	79 - 85 - 91	64 - 70 - 76
Power factor		%	97.1 - 97.3 - 97.2	97 - 98.2 - 99
Max. starting amperes		A	1 - 1 - 1	
FEATURES				
Controls		Microprocessor		
Timer		ON / OFF Timer (Max.72 hr)		
Fan speeds		3 and Automatic control		
Air filter		Washable, easy access		
Refrigerant control		Electronic expansion valve		
Operation sound (Hi / Me / Lo)		dB-A	39 / 35 / 29	
Refrigerant tubing connections		Flare type		
Refrigerant tube outer diameter	Narrow tube	mm (in)	9.52 (3 / 8)	
	Wide tube	mm (in)	12.7 (1 / 2)	
Drain connection		20A, OD26mm		
Drain pump		-		
Drain pump (drain connection)		Optional (RCS-SH80TG)		
Remote controller (option)		Optional / drain hose		
Color (Approximate value)		Munsell 10Y9.3 / 0.4, RAL 9010-GL		
DIMENSIONS & WEIGHT				
Dimensions	Height	mm (in)	615 (24 - 7 / 32)	694 (27 - 10 / 32)
	Width	mm (in)	1065 (41 - 30 / 32)	1157 (45 - 18 / 32)
	Depth	mm (in)	230 (9 - 2 / 32)	312 (12 - 9 / 32)
Net weight		kg (lb)	29 (64)	
Shipping weight		kg (lb)	31 (68)	
Shipping volume		m ³ (cu. ft)	0.251 (8.9)	

DATA SUBJECT TO CHANGE WITHOUT NOTICE.

Cooling :

Rating conditions(★) : Indoor air temperature 27 °C DB / 19 °C WB, Outdoor air temperature 35 °C DB

Heating :

Rating conditions(★) : Indoor air temperature 20 °C DB, Outdoor air temperature 7°C DB / 6°C DB

9. Floor-Standing Type (F Type)

Unit specifications (C)

MODEL No.	Indoor Unit		SPW-FR183GH56	
POWER SOURCE			220 - 230 - 240 V / 1 phase / 50Hz	
PERFORMANCE			Cooling	Heating
Capacity	kW		5.6	6.3
	BTU / h		19,000	21,000
Air circulation (Hi / Me / Lo)		m ³ / h	900 / 780 / 660	
Moisture removal (High)		Liters / h	2.5	—
ELECTRICAL RATINGS				
Voltage rating		V	220 - 230 - 240	
Available voltage range		V	198 - 264	
Running amperes*		A	0.54 - 0.56 - 0.58	0.37 - 0.41 - 0.43
Power input		W	116 - 126 - 136	79 - 91 - 101
Power factor		%	97.6 - 97.8 - 97.7	97.1 - 96.5 - 97.9
Max. starting amperes		A	1 - 1 - 1	
FEATURES				
Controls		Microprocessor		
Timer		ON / OFF Timer (Max.72 hr)		
Fan speeds		3 and Automatic control		
Air filter		Washable, easy access		
Refrigerant control		Electronic expansion valve		
Operation sound (Hi / Me / Lo)		dB-A	39 / 36 / 31	
Refrigerant tubing connections		Flare type		
Refrigerant tube outer diameter	Narrow tube	mm (in)	9.52 (3 / 8)	
	Wide tube	mm (in)	15.88 (5 / 8)	
Drain connection		20A, OD26mm		
Drain pump		—		
Drain pump (drain connection)		Optional (RCS-SH80TG)		
Remote controller (option)		Optional / drain hose		
Color (Approximate value)		Munsell 10Y9.3 / 0.4, RAL 9010-GL		
DIMENSIONS & WEIGHT				
Dimensions	Height	mm (in)	615 (24 - 7 / 32)	694 (27 - 10 / 32)
	Width	mm (in)	1380 (54 - 11 / 32)	1472 (57 - 30 / 32)
	Depth	mm (in)	230 (9 - 2 / 32)	312 (12 - 9 / 32)
Net weight		kg (lb)	39 (86)	
Shipping weight		kg (lb)	41 (90)	
Shipping volume		m ³ (cu. ft)	0.319 (11.3)	

DATA SUBJECT TO CHANGE WITHOUT NOTICE.

Cooling :

Rating conditions(★) : Indoor air temperature 27 °C DB / 19 °C WB, Outdoor air temperature 35 °C DB

Heating :

Rating conditions(★) : Indoor air temperature 20 °C DB, Outdoor air temperature 7°C DB / 6°C DB

9. Floor-Standing Type (F Type)

Unit specifications (D)

MODEL No.	Indoor Unit		SPW-FR253GH56	
POWER SOURCE			220 - 230 - 240 V / 1 phase / 50Hz	
PERFORMANCE			Cooling	Heating
Capacity	kW		7.1	8
	BTU / h		24,000	27,000
Air circulation (Hi / Me / Lo)		m ³ / h	1,020 / 840 / 720	
Moisture removal (High)		Liters / h	3.5	—
ELECTRICAL RATINGS				
Voltage rating		V	220 - 230 - 240	
Available voltage range		V	198 - 264	
Running amperes*		A	0.7 - 0.72 - 0.73	0.52 - 0.54 - 0.56
Power input		W	150 - 160 - 170	110 - 120 - 130
Power factor		%	97.4 - 96.6 - 97	96.2 - 96.6 - 96.7
Max. starting amperes		A	1 - 1 - 1	
FEATURES				
Controls		Microprocessor		
Timer		ON / OFF Timer (Max.72 hr)		
Fan speeds		3 and Automatic control		
Air filter		Washable, easy access		
Refrigerant control		Electronic expansion valve		
Operation sound (Hi / Me / Lo)		dB-A	41 / 38 / 35	
Refrigerant tubing connections		Flare type		
Refrigerant tube outer diameter	Narrow tube	mm (in)	9.52 (3 / 8)	
	Wide tube	mm (in)	15.88 (5 / 8)	
Drain connection		20A, OD26mm		
Drain pump		—		
Drain pump (drain connection)		Optional (RCS-SH80TG)		
Remote controller (option)		Optional / drain hose		
Color (Approximate value)		Munsell 10Y9.3 / 0.4, RAL 9010-GL		
DIMENSIONS & WEIGHT				
Dimensions	Height	mm (in)	615 (24 - 7 / 32)	694 (27 - 10 / 32)
	Width	mm (in)	1380 (54 - 11 / 32)	1472 (57 - 30 / 32)
	Depth	mm (in)	230 (9 - 2 / 32)	312 (12 - 9 / 32)
Net weight		kg (lb)	39 (86)	
Shipping weight		kg (lb)	41 (90)	
Shipping volume		m ³ (cu. ft)	0.319 (11.3)	

DATA SUBJECT TO CHANGE WITHOUT NOTICE.

Cooling :

Rating conditions(★) : Indoor air temperature 27 °C DB / 19 °C WB, Outdoor air temperature 35 °C DB

Heating :

Rating conditions(★) : Indoor air temperature 20 °C DB, Outdoor air temperature 7°C DB / 6°C DB

9. Floor-Standing Type (F Type)

9-2. Major component specifications

Indoor unit (A)

MODEL No.		SPW-FR93GH56	
Source		220 - 230 - 240 V / 1 phase / 50Hz	
Controller P.C.B. Ass'y		CR-X253GH (Microprocessor)	
Fan (Number...diameter)	mm	Centrifugal (1 ... ø 153)	
Fan motor			
Model...Nominal output	W	KFT6Q-11A3P ... 15 W	
Source		220 - 230 - 240 V / 1 phase / 50 Hz	
No. of pole...r.p.m. (230 V, High)	rpm.	6 ... 831	
Coil resistance (Ambient temperature 20°C)	Ω	BRN – WHT : 370.2 ORG – YEL : 168.0 WHT – VLT : 105.4 YEL – PNK : 92.16 VLT – ORG : 67.05	
Safety device			
Operating temperature	Open °C	130 ± 5	
	Close °C	(115 ± 5)	
Run capacitor	VAC, μF	440 V, 1.0 μF	
Electronic expansion valve			
Coil		DKV-MOZS550E0	
Coil resistance (at 20°C)	Ω	ORG – GRY : 46 , YEL – GRY : 46 RED – GRY : 46 , BLK – GRY : 46	
Valve body		IKV-24D12	
Heat exchanger			
Coil		Aluminum plate fin / Copper tube	
Rows...fin pitch	mm	3 ... 2.0	
Face area	m ²	0.102	

9. Floor-Standing Type (F Type)

Indoor unit (B)

MODEL No.		SPW-FR123GH56	
Source		220 - 230 - 240 V / 1 phase / 50Hz	
Controller P.C.B. Ass'y		CR-X253GH (Microprocessor)	
Fan (Number...diameter)	mm	Centrifugal (1 ... ø 153)	
Fan motor			
Model...Nominal output	W	KFT4Q-21B3P ... 20 W	
Source		220 - 230 - 240 V / 1 phase / 50 Hz	
No. of pole...r.p.m. (230 V, High)	rpm.	4 ... 1,102	
Coil resistance (Ambient temperature 20°C)	Ω	BRN – WHT : 217.7 ORG – YEL : 37.88 WHT – VLT : 37.33 YEL – PNK : 21.82 VLT – ORG : 22.48	
Safety device			
Operating temperature	Open °C	130 ± 5	
	Close °C	(115 ± 5)	
Run capacitor	VAC, μF	440 V, 2.0 μF	
Electronic expansion valve			
Coil		DKV-MOZS550E0	
Coil resistance (at 20°C)	Ω	ORG – GRY : 46 , YEL – GRY : 46 RED – GRY : 46 , BLK – GRY : 46	
Valve body		IKV-24D12	
Heat exchanger			
Coil		Aluminum plate fin / Copper tube	
Rows...fin pitch	mm	3 ... 2.0	
Face area	m ²	0.102	

1

9. Floor-Standing Type (F Type)

Indoor unit (C)

MODEL No.		SPW-FR183GH56	
Source		220 - 230 - 240 V / 1 phase / 50Hz	
Controller P.C.B. Ass'y		CR-X253GH (Microprocessor)	
Fan (Number...diameter)	mm	Centrifugal (2 ... ø 153)	
Fan motor			
Model...Nominal output	W	KFG4Q-61C3P ... 60 W	
Source		220 - 230 - 240 V / 1 phase / 50 Hz	
No. of pole...r.p.m. (230 V, High)	rpm.	4 ... 1,007	
Coil resistance (Ambient temperature 20°C)	Ω	BRN – WHT : 67.62 ORG – YEL : 17.36 WHT – VLT : 18.47 YEL – PNK : 5.18 VLT – ORG : 10.10	
Safety device			
Operating temperature	Open °C	130 ± 5	
	Close °C	(115 ± 5)	
Run capacitor	VAC, μF	440 V, 2.0 μF	
Electronic expansion valve			
Coil		DKV-MOZS550E0	
Coil resistance (at 20°C)	Ω	ORG – GRY : 46 , YEL – GRY : 46 RED – GRY : 46 , BLK – GRY : 46	
Valve body		IKV-24D12	
Heat exchanger			
Coil		Aluminum plate fin / Copper tube	
Rows...fin pitch	mm	3 ... 2.0	
Face area	m ²	0.165	

9. Floor-Standing Type (F Type)

Indoor unit (D)

MODEL No.		SPW-FR253GH56	
Source		220 - 230 - 240 V / 1 phase / 50Hz	
Controller P.C.B. Ass'y		CR-X253GH (Microprocessor)	
Fan (Number...diameter)	mm	Centrifugal (2 ... ø 153)	
Fan motor			
Model...Nominal output	W	KFG4Q-61C3P ... 60 W	
Source		220 - 230 - 240 V / 1 phase / 50 Hz	
No. of pole...r.p.m. (230 V, High)	rpm.	4 ... 1,122	
Coil resistance (Ambient temperature 20°C)	Ω	BRN – WHT : 67.62 ORG – YEL : 17.36 WHT – VLT : 18.47 YEL – PNK : 5.18 VLT – ORG : 10.10	
Safety device			
Operating temperature	Open °C	130 ± 5	
	Close °C	(115 ± 5)	
Run capacitor	VAC, μF	440 V, 3.5 μF	
Electronic expansion valve			
Coil		DKV-MOZS550E0	
Coil resistance (at 20°C)	Ω	ORG – GRY : 46 , YEL – GRY : 46 RED – GRY : 46 , BLK – GRY : 46	
Valve body		IKV-24D12	
Heat exchanger			
Coil		Aluminum plate fin / Copper tube	
Rows...fin pitch	mm	3 ... 2.0	
Face area	m ²	0.165	

1

9. Floor-Standing Type (F Type)

9-3. Other component specifications

MODEL NO.	Indoor Unit	SPW-FR93 ~ 253GH56	
Power Transformer		ATR-II215TB	
Rated			
Primary	V, Hz	AC 230 V, 50 Hz	
Secondary		10.2 V 1.4 A	
		14 V 0.5 A	
Coil resistance	Ω	WHT – WHT : 112 , BRN – BRN : 0.5 RED – RED : 2.3	
Thermal cut off temperature	$^{\circ}\text{C}$	150	
Thermistor (Coil sensor)		PBC-41E-S25 , PBC-41E-S35	
Resistance	K Ω	-10 $^{\circ}\text{C}$: 23.7 \pm 5 % , 20 $^{\circ}\text{C}$: 6.5 \pm 5 % -5 $^{\circ}\text{C}$: 18.8 \pm 5 % , 30 $^{\circ}\text{C}$: 4.4 \pm 5 % 0 $^{\circ}\text{C}$: 15.0 \pm 5 % , 40 $^{\circ}\text{C}$: 3.1 \pm 5 % 5 $^{\circ}\text{C}$: 12.1 \pm 5 % , 45 $^{\circ}\text{C}$: 2.6 \pm 5 % 10 $^{\circ}\text{C}$: 9.7 \pm 5 %	
Thermistor (Room or coil sensor)		KTEC-35-S6	
Resistance	K Ω	0 $^{\circ}\text{C}$: 16.5 \pm 5 % , 40 $^{\circ}\text{C}$: 2.7 \pm 5 % 5 $^{\circ}\text{C}$: 12.8 \pm 5 % , 45 $^{\circ}\text{C}$: 2.2 \pm 5 % 10 $^{\circ}\text{C}$: 10.0 \pm 5 % , 50 $^{\circ}\text{C}$: 1.8 \pm 5 % 20 $^{\circ}\text{C}$: 6.3 \pm 5 % , 55 $^{\circ}\text{C}$: 1.5 \pm 5 % 30 $^{\circ}\text{C}$: 4.0 \pm 5 %	
Electronic expansion valve			
Valve body		IKV-24D12 (SPW-FR93 ~ 253GH56)	
Coil		DKV-MOZS550E0 (SPW-FR93 ~ 253GH56)	

9. Floor-Standing Type (F Type)

9-4. Dimensional data

Indoor unit : 9, 12, 18, 25 Type

Type \ Size	A	B	C	Narrow tube	Wide tube
9, 12	1065	665	632	9.52	12.7
18,25	1380	980	947	9.52	15.88

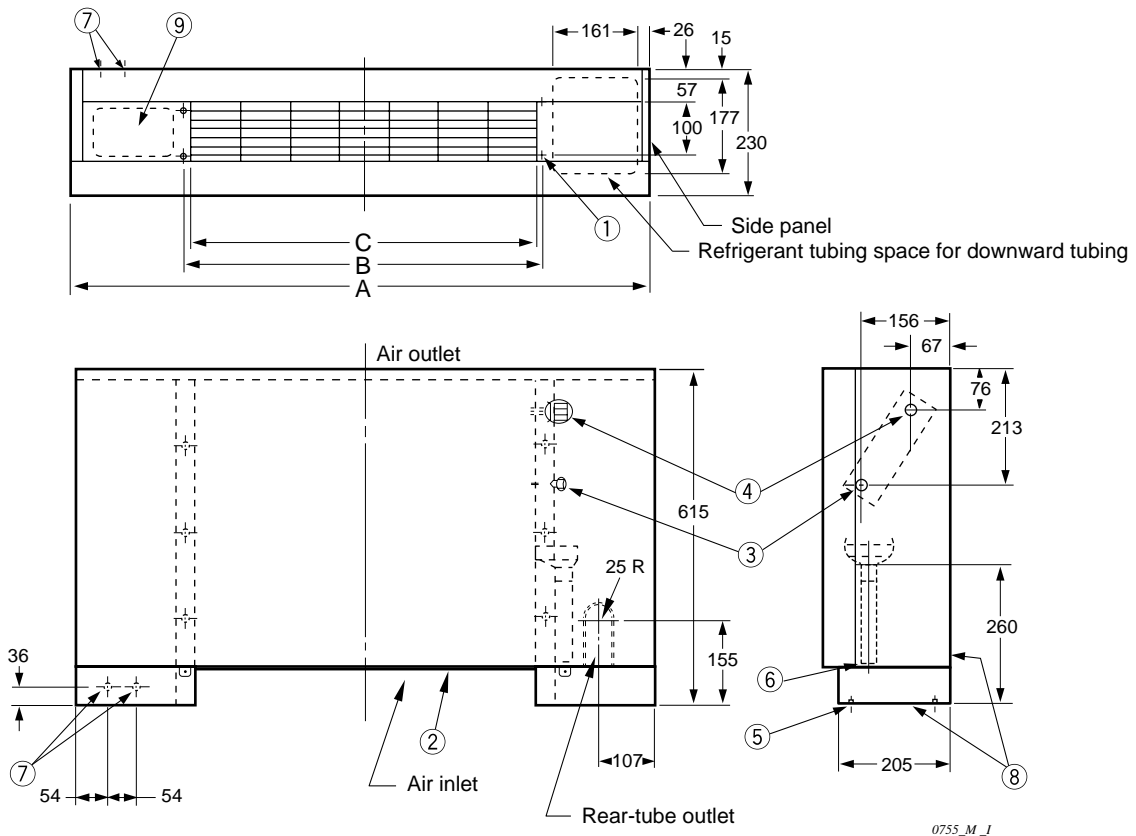

- ① 4-Ø12 hole (For fastening the indoor unit to the floor by screws.)
- ② Air filter
- ③ Refrigerant connection outlet (narrow tube)
- ④ Refrigerant connection outlet (wide tube)
- ⑤ Level adjusting bolt
- ⑥ Drain outlet (20 A)
- ⑦ Power cord outlet (downward, rear)
- ⑧ Refrigerant tubing outlet (downward, rear)
- ⑨ Location for mounting the remote controller (remote controller is attachable in the room)



0755_M_I

9. Floor-Standing Type (F Type)

9-5. Noise criterion curves

MODEL	: SPW-FR93GH56
SOUND LEVEL	: HIGH 33 dB(A), NC 27
	: LOW 28 dB(A), NC 23
CONDITION	: In front of the unit 1 m, HEIGHT 1 m
SOURCE	: 220 - 230 - 240 V, 1 Phase, 50 Hz

MODEL	: SPW-FR123GH56
SOUND LEVEL	: HIGH 39 dB(A), NC 33
	: LOW 29 dB(A), NC 23
CONDITION	: In front of the unit 1 m, HEIGHT 1 m
SOURCE	: 220 - 230 - 240 V, 1 Phase, 50 Hz

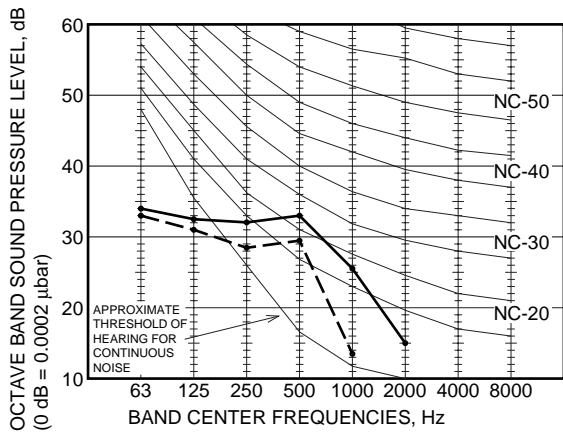

0834_V_I

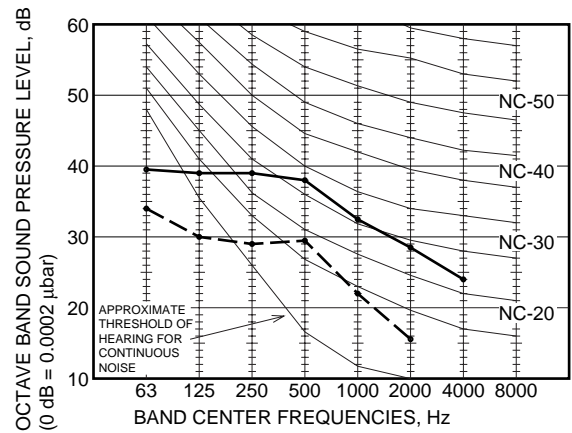

0835_V_I

MODEL	: SPW-FR183GH56
SOUND LEVEL	: HIGH 39 dB(A), NC 34
	: LOW 31 dB(A), NC 26
CONDITION	: In front of the unit 1 m, HEIGHT 1 m
SOURCE	: 220 - 230 - 240 V, 1 Phase, 50 Hz

MODEL	: SPW-FR253GH56
SOUND LEVEL	: HIGH 41 dB(A), NC 37
	: LOW 35 dB(A), NC 30
CONDITION	: In front of the unit 1 m, HEIGHT 1 m
SOURCE	: 220 - 230 - 240 V, 1 Phase, 50 Hz

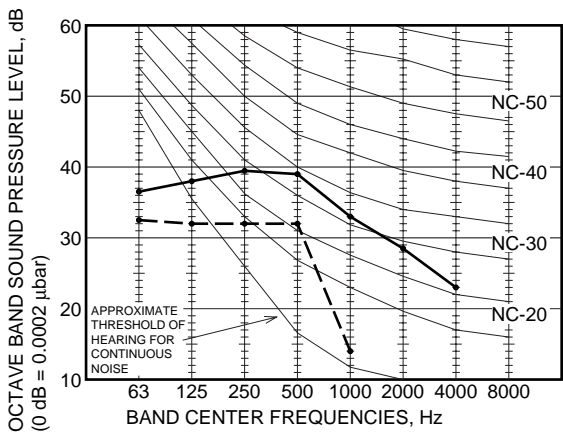

0836_V_I

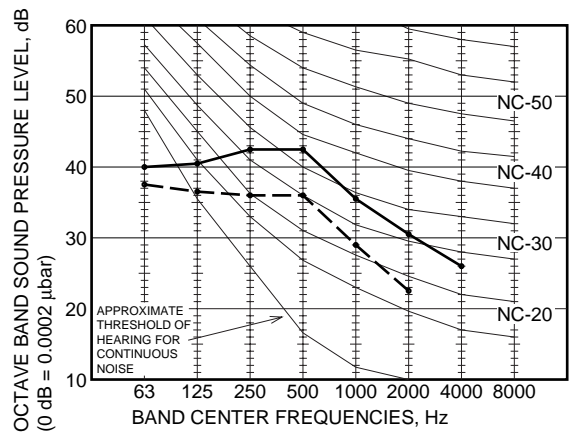

0837_V_I

9. Floor-Standing Type (F Type)

9-6. Air throw distance chart



Model: 9 Type

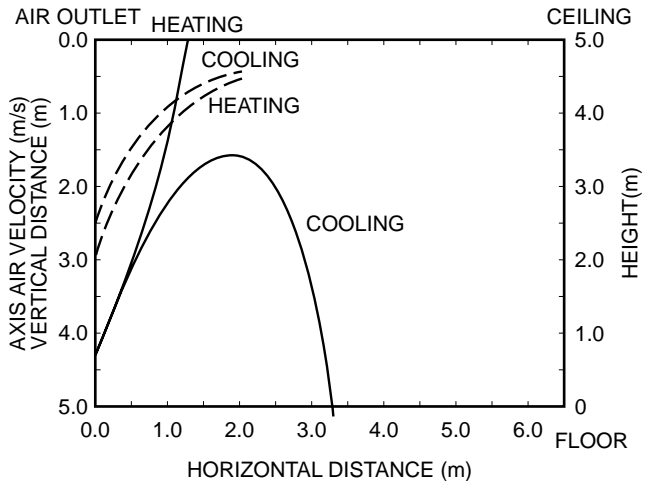

0838_V_J

Model: 12 Type

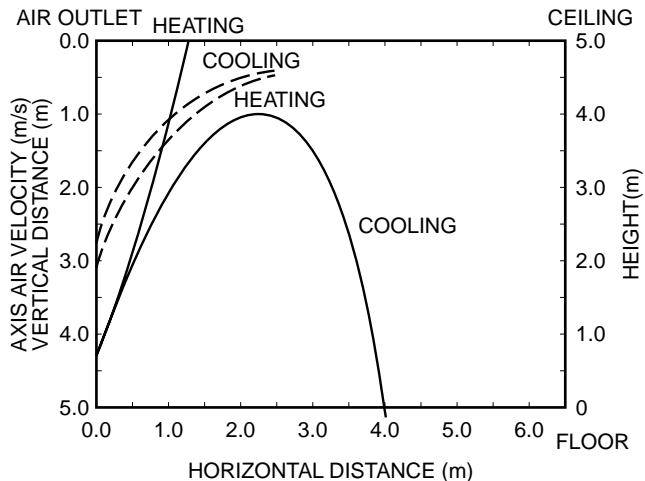

0839_V_J

Model: 18 Type

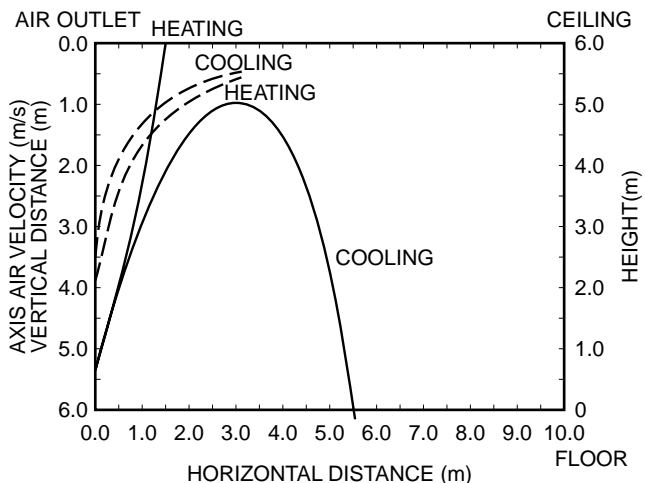

0840_V_J

Model: 25 Type

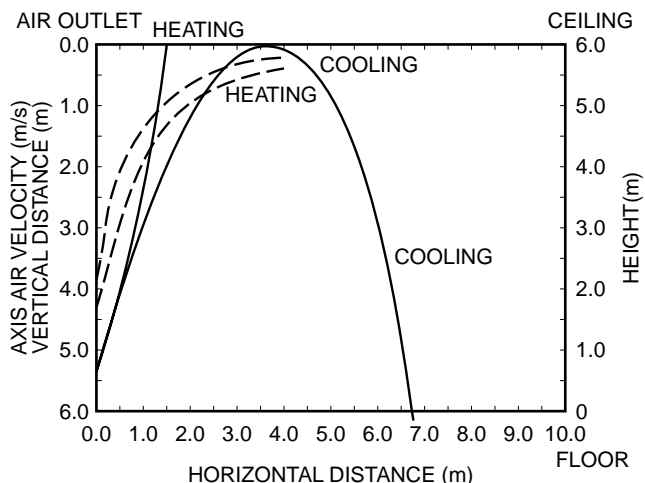

0841_V_J

Condition Fan Speed : Hi
 Room air temp. : 27 °C DB in cooling mode
 20 °C DB in heating mode

10. Conceal Floor-Standing Type (FM Type)

10-1. Specifications

Unit specifications (A)

MODEL No.	Indoor Unit		SPW-FMR93GH56	
POWER SOURCE			220 - 230 - 240 V / 1 phase / 50Hz	
PERFORMANCE			Cooling	Heating
Capacity	kW		2.8	3.2
	BTU / h		9,600	11,000
Air circulation (Hi / Me / Lo)		m ³ / h	420 / 360 / 300	
Moisture removal (High)		Liters / h	1.3	—
ELECTRICAL RATINGS				
Voltage rating		V	220 - 230 - 240	
Available voltage range		V	198 – 264	
Running amperes*		A	0.24 - 0.25 - 0.26	0.17 - 0.18 - 0.19
Power input		W	51 - 56 - 61	36 - 40 - 45
Power factor		%	96.6 - 97.4 - 97.8	96.3 - 96.6 - 98.7
Max. starting amperes		A	1 - 1 - 1	
FEATURES				
Controls		Microprocessor		
Timer		ON / OFF Timer (Max.72 hr)		
Fan speeds		3 and Automatic control		
Air filter		Washable, easy access		
Refrigerant control		Electronic expansion valve		
Operation sound (Hi / Me / Lo)		dB-A	33 / 30 / 28	
Refrigerant tubing connections		Flare type		
Refrigerant tube outer diameter	Narrow tube	mm (in)	9.52 (3 / 8)	
	Wide tube	mm (in)	12.7 (1 / 2)	
Drain connection		20A, OD26mm		
Drain pump		—		
Drain pump (drain connection)		Optional (RCS-SH80TG)		
Remote controller (option)		Optional / drain hose		
DIMENSIONS & WEIGHT				
Dimensions	Height	mm (in)	616 (24 - 8 / 32)	679 (26 - 23 / 32)
	Width	mm (in)	904 (35 - 19 / 32)	976 (38 - 14 / 32)
	Depth	mm (in)	229 (9 - 1 / 32)	312 (12 - 9 / 32)
Net weight		kg (lb)	21 (46)	
Shipping weight		kg (lb)	23 (51)	
Shipping volume		m ³ (cu. ft)	0.207 (7.3)	

DATA SUBJECT TO CHANGE WITHOUT NOTICE.

Cooling :

Rating conditions(★) : Indoor air temperature 27 °C DB / 19 °C WB, Outdoor air temperature 35 °C DB

Heating :

Rating conditions(★) : Indoor air temperature 20 °C DB, Outdoor air temperature 7°C DB / 6°C DB

10. Concealed Floor-Standing Type (FM Type)

Unit specifications (B)

MODEL No.	Indoor Unit		SPW-FMR123GH56	
POWER SOURCE			220 - 230 - 240 V / 1 phase / 50Hz	
PERFORMANCE			Cooling	Heating
Capacity	kW		3.6	4.2
	BTU / h		12,000	14,000
Air circulation (Hi / Me / Lo)		m ³ / h	540 / 420 / 360	
Moisture removal (High)		Liters / h	1.7	—
ELECTRICAL RATINGS				
Voltage rating		V	220 - 230 - 240	
Available voltage range		V	198 - 264	
Running amperes*		A	0.37 - 0.38 - 0.39	0.3 - 0.31 - 0.32
Power input		W	79 - 85 - 91	64 - 70 - 76
Power factor		%	97.1 - 97.3 - 97.2	97 - 98.2 - 99
Max. starting amperes		A	1 - 1 - 1	
FEATURES				
Controls		Microprocessor		
Timer		ON / OFF Timer (Max.72 hr)		
Fan speeds		3 and Automatic control		
Air filter		Washable, easy access		
Refrigerant control		Electronic expansion valve		
Operation sound (Hi / Me / Lo)		dB-A	39 / 35 / 29	
Refrigerant tubing connections		Flare type		
Refrigerant tube outer diameter	Narrow tube	mm (in)	9.52 (3 / 8)	
	Wide tube	mm (in)	12.7 (1 / 2)	
Drain connection		20A, OD26mm		
Drain pump		-		
Drain pump (drain connection)		Optional (RCS-SH80TG)		
Remote controller (option)		Optional / drain hose		
DIMENSIONS & WEIGHT				
Dimensions	Height	mm (in)	616 (24 - 8 / 32)	679 (26 - 23 / 32)
	Width	mm (in)	904 (35 - 19 / 32)	976 (38 - 14 / 32)
	Depth	mm (in)	229 (9 - 1 / 32)	312 (12 - 9 / 32)
Net weight		kg (lb)	21 (64)	
Shipping weight		kg (lb)	23 (51)	
Shipping volume		m ³ (cu. ft)	0.207 (7.3)	

DATA SUBJECT TO CHANGE WITHOUT NOTICE.

Cooling :

Rating conditions(★) : Indoor air temperature 27 °C DB / 19 °C WB, Outdoor air temperature 35 °C DB

Heating :

Rating conditions(★) : Indoor air temperature 20 °C DB, Outdoor air temperature 7°C DB / 6°C DB

1

10. Concealed Floor-Standing Type (FM Type)

Unit specifications (C)

MODEL No.	Indoor Unit		SPW-FMR183GH56	
POWER SOURCE			220 - 230 - 240 V / 1 phase / 50Hz	
PERFORMANCE			Cooling	Heating
Capacity	kW		5.6	6.3
	BTU / h		19,000	21,000
Air circulation (Hi / Me / Lo)		m ³ / h	900 / 780 / 660	
Moisture removal (High)		Liters / h	2.5	—
ELECTRICAL RATINGS				
Voltage rating		V	220 - 230 - 240	
Available voltage range		V	198 - 264	
Running amperes*		A	0.54 - 0.56 - 0.58	0.37 - 0.41 - 0.43
Power input		W	116 - 126 - 136	79 - 91 - 101
Power factor		%	97.6 - 97.8 - 97.7	97.1 - 96.5 - 97.9
Max. starting amperes		A	1 - 1 - 1	
FEATURES				
Controls		Microprocessor		
Timer		ON / OFF Timer (Max.72 hr)		
Fan speeds		3 and Automatic control		
Air filter		Washable, easy access		
Refrigerant control		Electronic expansion valve		
Operation sound (Hi / Me / Lo)		dB-A	39 / 36 / 31	
Refrigerant tubing connections		Flare type		
Refrigerant tube outer diameter	Narrow tube	mm (in)	9.52 (3 / 8)	
	Wide tube	mm (in)	15.88 (5 / 8)	
Drain connection		20A, OD26mm		
Drain pump		—		
Drain pump (drain connection)		Optional (RCS-SH80TG)		
Remote controller (option)		Optional / drain hose		
DIMENSIONS & WEIGHT				
Dimensions	Height	mm (in)	616 (24 - 8 / 32)	679 (26 - 23 / 32)
	Width	mm (in)	1219 (47 - 32 / 32)	1291 (50 - 26 / 32)
	Depth	mm (in)	229 (9 - 1 / 32)	312 (12 - 9 / 32)
Net weight		kg (lb)	28 (62)	
Shipping weight		kg (lb)	31 (68)	
Shipping volume		m ³ (cu. ft)	0.273 (9.6)	

DATA SUBJECT TO CHANGE WITHOUT NOTICE.

Cooling :

Rating conditions(★) : Indoor air temperature 27 °C DB / 19 °C WB, Outdoor air temperature 35 °C DB

Heating :

Rating conditions(★) : Indoor air temperature 20 °C DB, Outdoor air temperature 7°C DB / 6°C DB

10. Concealed Floor-Standing Type (FM Type)

Unit specifications (D)

MODEL No.	Indoor Unit		SPW-FMR253GH56	
POWER SOURCE			220 - 230 - 240 V / 1 phase / 50Hz	
PERFORMANCE			Cooling	Heating
Capacity	kW		7.1	8
	BTU / h		24,000	27,000
Air circulation (Hi / Me / Lo)		m ³ / h	1,020 / 840 / 720	
Moisture removal (High)		Liters / h	3.5	—
ELECTRICAL RATINGS				
Voltage rating		V	220 - 230 - 240	
Available voltage range		V	198 - 264	
Running amperes*		A	0.7 - 0.72 - 0.73	0.52 - 0.54 - 0.56
Power input		W	150 - 160 - 170	110 - 120 - 130
Power factor		%	97.4 - 96.6 - 97	96.2 - 96.6 - 96.7
Max. starting amperes		A	1 - 1 - 1	
FEATURES				
Controls		Microprocessor		
Timer		ON / OFF Timer (Max.72 hr)		
Fan speeds		3 and Automatic control		
Air filter		Washable, easy access		
Refrigerant control		Electronic expansion valve		
Operation sound (Hi / Me / Lo)		dB-A	41 / 38 / 35	
Refrigerant tubing connections		Flare type		
Refrigerant tube outer diameter	Narrow tube	mm (in)	9.52 (3 / 8)	
	Wide tube	mm (in)	15.88 (5 / 8)	
Drain connection		20A, OD26mm		
Drain pump		—		
Drain pump (drain connection)		Optional (RCS-SH80TG)		
Remote controller (option)		Optional / drain hose		
DIMENSIONS & WEIGHT				
Dimensions	Height	mm (in)	616 (24 - 8 / 32)	679 (26 - 23 / 32)
	Width	mm (in)	1219 (47 - 32 / 32)	1291 (50 - 26 / 32)
	Depth	mm (in)	229 (9 - 1 / 32)	312 (12 - 9 / 32)
Net weight		kg (lb)	28 (62)	
Shipping weight		kg (lb)	31 (68)	
Shipping volume		m ³ (cu. ft)	0.273 (9.6)	

DATA SUBJECT TO CHANGE WITHOUT NOTICE.

Cooling :

Rating conditions(★) : Indoor air temperature 27 °C DB / 19 °C WB, Outdoor air temperature 35 °C DB

Heating :

Rating conditions(★) : Indoor air temperature 20 °C DB, Outdoor air temperature 7°C DB / 6°C DB

1

10. Concealed Floor-Standing Type (FM Type)

10-2. Major component specifications

Indoor unit (A)

MODEL No.		SPW-FMR93GH56	
Source		220 - 230 - 240 V / 1 phase / 50Hz	
Controller P.C.B. Ass'y		CR-X253GH (Microprocessor)	
Fan (Number...diameter)	mm	Centrifugal (1 ... ø 153)	
Fan motor			
Model...Nominal output	W	KFT6Q-11A3P ... 15 W	
Source		220 - 230 - 240 V / 1 phase / 50 Hz	
No. of pole...r.p.m. (230 V, High)	rpm.	6 ... 831	
Coil resistance (Ambient temperature 20°C)	Ω	BRN – WHT : 370.2 ORG – YEL : 168.0 WHT – VLT : 105.4 YEL – PNK : 92.16 VLT – ORG : 67.05	
Safety device			
Operating temperature	Open °C	130 ± 5	
	Close °C	(115 ± 5)	
Run capacitor	VAC, μF	440 V, 1.0 μF	
Electronic expansion valve			
Coil		DKV-MOZS550E0	
Coil resistance (at 20°C)	Ω	ORG – GRY : 46 , YEL – GRY : 46 RED – GRY : 46 , BLK – GRY : 46	
Valve body		IKV-24D12	
Heat exchanger			
Coil		Aluminum plate fin / Copper tube	
Rows...fin pitch	mm	3 ... 2.0	
Face area	m ²	0.102	

10. Concealed Floor-Standing Type (FM Type)

Indoor unit (B)

MODEL No.		SPW-FMR123GH56	
Source		220 - 230 - 240 V / 1 phase / 50Hz	
Controller P.C.B. Ass'y		CR-X253GH (Microprocessor)	
Fan (Number...diameter)	mm	Centrifugal (1 ... ø 153)	
Fan motor			
Model...Nominal output	W	KFT4Q-21B3P ... 30 W	
Source		220 - 230 - 240 V / 1 phase / 50 Hz	
No. of pole...r.p.m. (230 V, High)	rpm.	4 ... 1,102	
Coil resistance (Ambient temperature 20°C)	Ω	BRN – WHT : 217.7 ORG – YEL : 37.88 WHT – VLT : 37.33 YEL – PNK : 21.82 VLT – ORG : 22.48	
Safety device			
Operating temperature	Open °C	130 ± 5	
	Close °C	(115 ± 5)	
Run capacitor	VAC, μF	440 V, 2.0 μF	
Electronic expansion valve			
Coil		DKV-MOZS550E0	
Coil resistance (at 20°C)	Ω	ORG – GRY : 46 , YEL – GRY : 46 RED – GRY : 46 , BLK – GRY : 46	
Valve body		IKV-24D12	
Heat exchanger			
Coil		Aluminum plate fin / Copper tube	
Rows...fin pitch	mm	3 ... 2.0	
Face area	m ²	0.102	

1

10. Concealed Floor-Standing Type (FM Type)

Indoor unit (C)

MODEL No.		SPW-FMR183GH56	
Source		220 - 230 - 240 V / 1 phase / 50Hz	
Controller P.C.B. Ass'y		CR-X253GH (Microprocessor)	
Fan (Number...diameter)	mm	Centrifugal (2 ... ø 153)	
Fan motor			
Model...Nominal output	W	KFG4Q-61C3P ... 60 W	
Source		220 - 230 - 240 V / 1 phase / 50 Hz	
No. of pole...r.p.m. (230 V, High)	rpm.	4 ... 1,007	
Coil resistance (Ambient temperature 20°C)	Ω	BRN – WHT : 67.62 ORG – YEL : 17.36 WHT – VLT : 18.47 YEL – PNK : 5.18 VLT – ORG : 10.10	
Safety device			
Operating temperature	Open °C	130 ± 5	
	Close °C	(115 ± 5)	
Run capacitor	VAC, μF	440 V, 2.0 μF	
Electronic expansion valve			
Coil		DKV-MOZS550E0	
Coil resistance (at 20°C)	Ω	ORG – GRY : 46 , YEL – GRY : 46 RED – GRY : 46 , BLK – GRY : 46	
Valve body		IKV-24D12	
Heat exchanger			
Coil		Aluminum plate fin / Copper tube	
Rows...fin pitch	mm	3 ... 2.0	
Face area	m ²	0.165	

10. Concealed Floor-Standing Type (FM Type)

Indoor unit (D)

MODEL No.		SPW-FMR253GH56	
Source		220 - 230 - 240 V / 1 phase / 50Hz	
Controller P.C.B. Ass'y		CR-X253GH (Microprocessor)	
Fan (Number...diameter)	mm	Centrifugal (2 ... ø 153)	
Fan motor			
Model...Nominal output	W	KFG4Q-61C3P ... 60 W	
Source		220 - 230 - 240 V / 1 phase / 50 Hz	
No. of pole...r.p.m. (230 V, High)	rpm.	4 ... 1,122	
Coil resistance (Ambient temperature 20°C)	Ω	BRN – WHT : 67.62 ORG – YEL : 17.36 WHT – VLT : 18.47 YEL – PNK : 5.18 VLT – ORG : 10.10	
Safety device			
Operating temperature	Open °C	130 ± 5	
	Close °C	(115 ± 5)	
Run capacitor	VAC, μF	440 V, 3.5 μF	
Electronic expansion valve			
Coil		DKV-MOZS550E0	
Coil resistance (at 20°C)	Ω	ORG – GRY : 46 , YEL – GRY : 46 RED – GRY : 46 , BLK – GRY : 46	
Valve body		IKV-24D12	
Heat exchanger			
Coil		Aluminum plate fin / Copper tube	
Rows...fin pitch	mm	3 ... 2.0	
Face area	m ²	0.165	

1

10. Concealed Floor-Standing Type (FM Type)

10-3. Other component specifications

MODEL NO.	Indoor Unit	SPW-FMR93 ~ 253GH56	
Power Transformer		ATR-II215TB	
Rated			
Primary	V, Hz	AC 230 V, 50 Hz	
Secondary		10.2 V 1.4 A	
		14 V 0.5 A	
Coil resistance	Ω	WHT – WHT : 112 , BRN – BRN : 0.5 RED – RED : 2.3	
Thermal cut off temperature	$^{\circ}\text{C}$	150	
Thermistor (Coil sensor)		PBC-41E-S25 , PBC-41E-S35	
Resistance	$\text{K}\Omega$	-10 $^{\circ}\text{C}$: 23.7 \pm 5 % , 20 $^{\circ}\text{C}$: 6.5 \pm 5 % -5 $^{\circ}\text{C}$: 18.8 \pm 5 % , 30 $^{\circ}\text{C}$: 4.4 \pm 5 % 0 $^{\circ}\text{C}$: 15.0 \pm 5 % , 40 $^{\circ}\text{C}$: 3.1 \pm 5 % 5 $^{\circ}\text{C}$: 12.1 \pm 5 % , 45 $^{\circ}\text{C}$: 2.6 \pm 5 % 10 $^{\circ}\text{C}$: 9.7 \pm 5 %	
Thermistor (Room or coil sensor)		KTEC-35-S6	
Resistance	$\text{K}\Omega$	0 $^{\circ}\text{C}$: 16.5 \pm 5 % , 40 $^{\circ}\text{C}$: 2.7 \pm 5 % 5 $^{\circ}\text{C}$: 12.8 \pm 5 % , 45 $^{\circ}\text{C}$: 2.2 \pm 5 % 10 $^{\circ}\text{C}$: 10.0 \pm 5 % , 50 $^{\circ}\text{C}$: 1.8 \pm 5 % 20 $^{\circ}\text{C}$: 6.3 \pm 5 % , 55 $^{\circ}\text{C}$: 1.5 \pm 5 % 30 $^{\circ}\text{C}$: 4.0 \pm 5 %	
Electronic expansion valve			
Valve body		IKV-24D12 (SPW-FMR93 ~ 253GH56)	
Coil		DKV-MOZS550E0 (SPW-FMR93 ~ 253GH56)	

10. Concealed Floor-Standing Type (FM Type)

10-4. Dimensional data

Indoor unit : 9, 12, 18, 25 Type

Type \ Size	A	B	C	D	Narrow tube	Wide tube
9, 12	858	692	672	665	9.52	12.7
18,25	1173	1007	1002	980	9.52	15.88

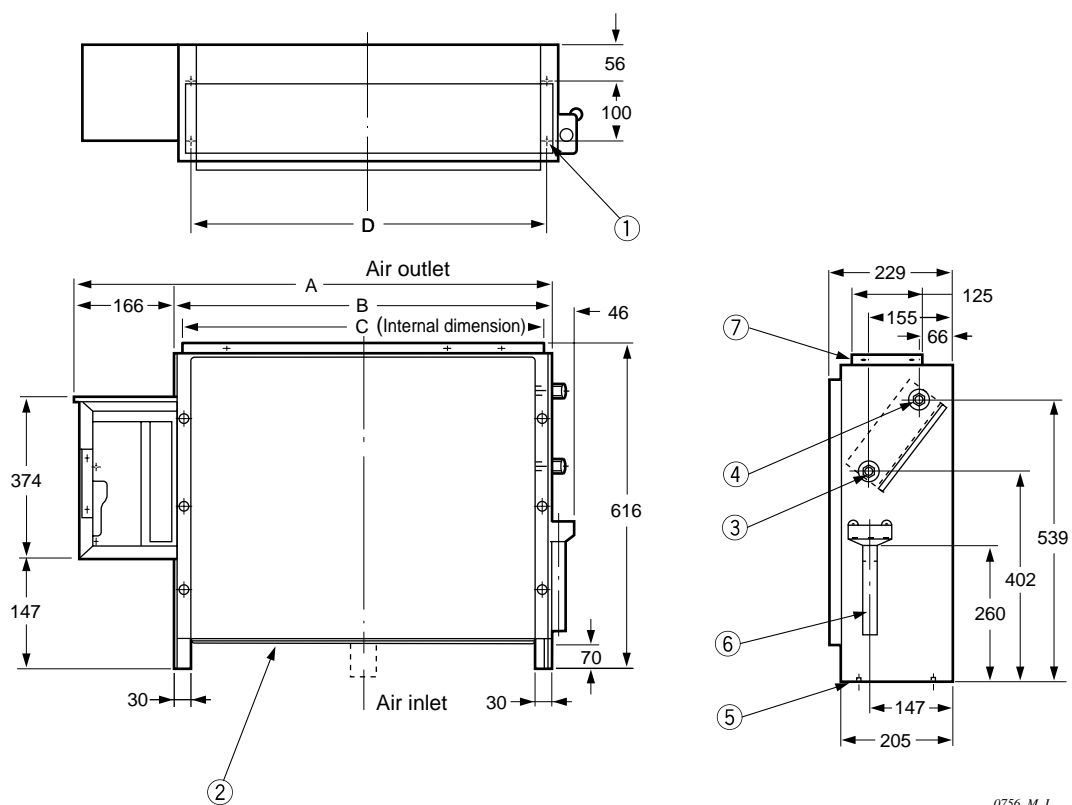

0756_M_1

- ① 4-Ø12 hole (For fastening the indoor unit to the floor by screws.)
- ② Air filter
- ③ Refrigerant connection outlet (narrow tube)
- ④ Refrigerant connection outlet (wide tube)
- ⑤ Level adjusting bolt
- ⑥ Drain outlet (20 A)
- ⑦ Flange for the air-outlet duct



10. Concealed Floor-Standing Type (FM Type)

10-5. Noise criterion curves

MODEL	: SPW-FMR93GH56
SOUND LEVEL	: HIGH 33 dB(A), NC 27
	: LOW 28 dB(A), NC 23
CONDITION	: In front of the unit 1 m, HEIGHT 1 m
SOURCE	: 220 - 230 - 240 V, 1 Phase, 50 Hz

MODEL	: SPW-FMR123GH56
SOUND LEVEL	: HIGH 39 dB(A), NC 33
	: LOW 29 dB(A), NC 23
CONDITION	: In front of the unit 1 m, HEIGHT 1 m
SOURCE	: 220 - 230 - 240 V, 1 Phase, 50 Hz

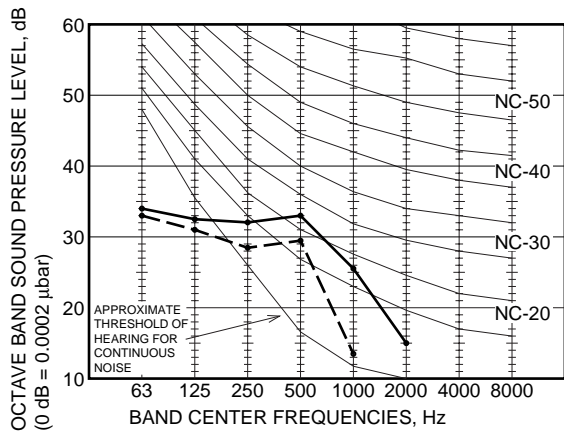

0834_V_I

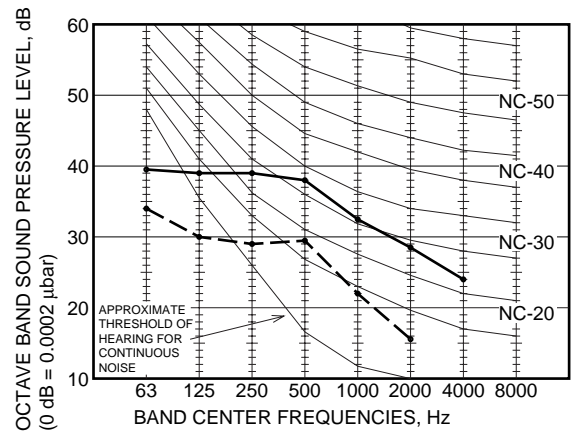

0835_V_I

MODEL	: SPW-FMR183GH56
SOUND LEVEL	: HIGH 39 dB(A), NC 34
	: LOW 31 dB(A), NC 26
CONDITION	: In front of the unit 1 m, HEIGHT 1 m
SOURCE	: 220 - 230 - 240 V, 1 Phase, 50 Hz

MODEL	: SPW-FMR253GH56
SOUND LEVEL	: HIGH 41 dB(A), NC 37
	: LOW 35 dB(A), NC 30
CONDITION	: In front of the unit 1 m, HEIGHT 1 m
SOURCE	: 220 - 230 - 240 V, 1 Phase, 50 Hz

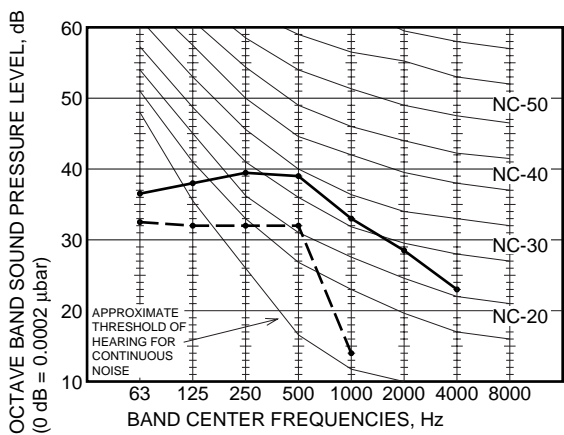

0836_V_I

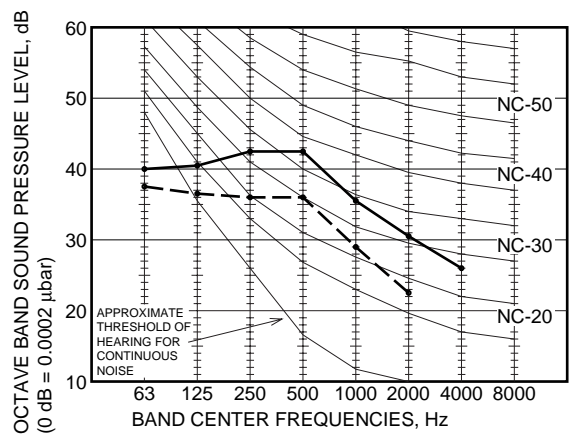

0837_V_I

10. Concealed Floor-Standing Type (FM Type)

10-6. Air throw distance chart



Model: 9 Type

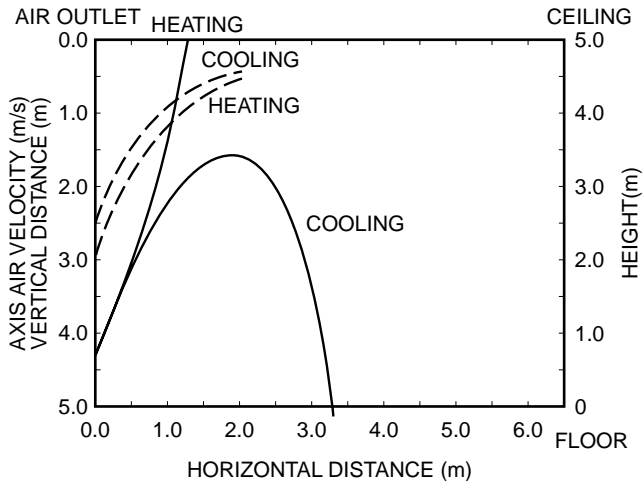

0838_V_J

Model: 12 Type

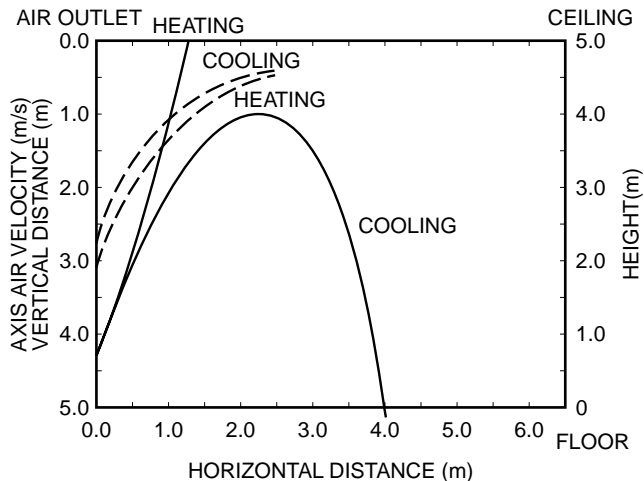

0839_V_J

Model: 18 Type

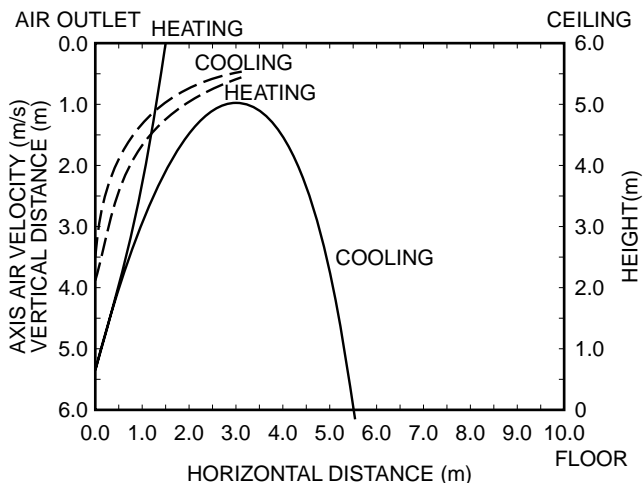

0840_V_J

Model: 25 Type

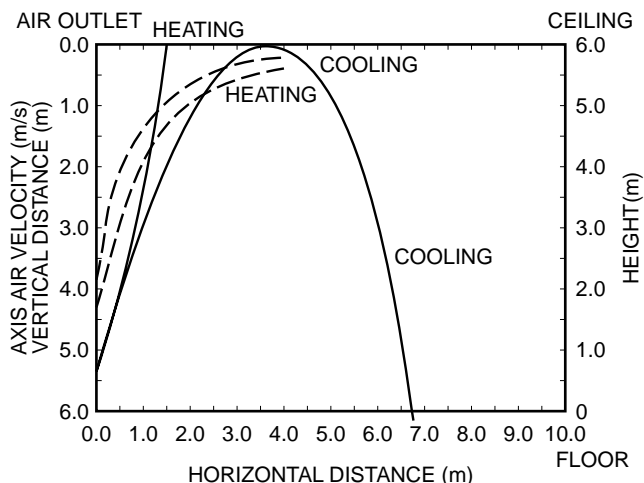

0841_V_J

Condition Fan Speed : Hi
 Room air temp. : 27 °C DB in cooling mode
 20 °C DB in heating mode

10. Concealed Floor-Standing Type (FM Type)

10-7. Indoor fan performance

How to Read the Diagram

The vertical axis is the EXTERNAL STATIC PRESSURE (mmAq) while the horizontal axis represents the AIR FLOW (m³/minute). The characteristic curve for the "H", "Med", and "Lo" fan speed control.

The name plate values are shown based on the "H" air flow. Therefore in the case of the 25 type the flow is 17 m³/minute, while the EXTERNAL STATIC PRESSURE is 1.5 mmAq at "H" position. If the external static pressure is too great (due to long extension of duct, for example), the air flow volume may drop too low at each air outlet.

9 Type

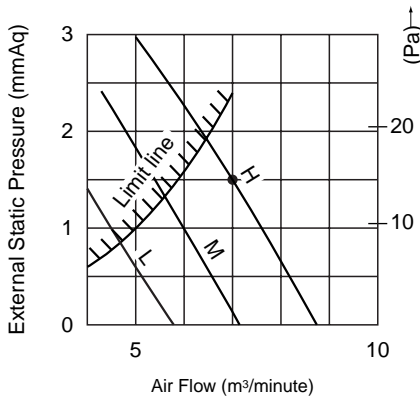

12 Type

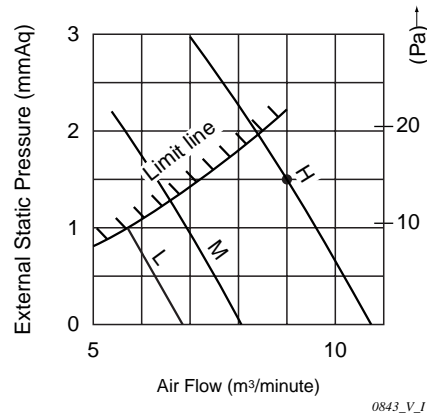

18 Type

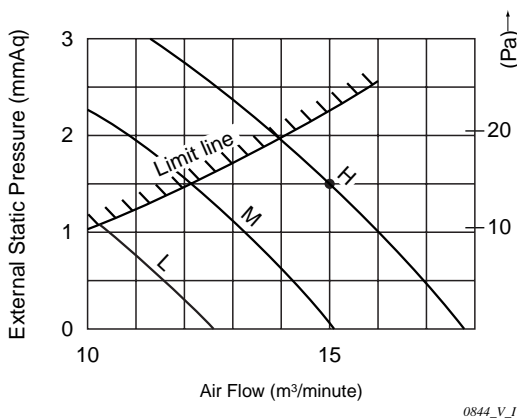

25 Type

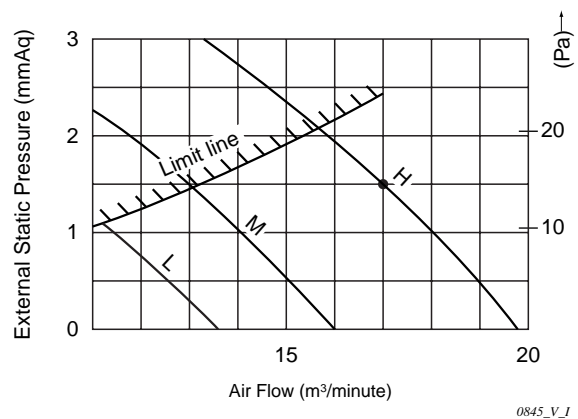

11. 1-Way Air Discharge Semi-concealed-Slim Type (SL Type)

11-1. Specifications

Unit specifications (A)

MODEL No.	Indoor Unit		SPW-SLR93GH56					
POWER SOURCE			220 - 230 - 240 V / 1 phase / 50Hz					
PERFORMANCE			Cooling			Heating		
Capacity	kW		2.8			3.2		
	BTU / h		9,600			11,000		
Air circulation (Hi / Me / Lo)	m ³ /h		840 (750)* / 630 / 540					
Moisture removal (High)	Liters/h		0.6			—		
ELECTRICAL RATINGS								
Voltage rating	V		220	230	240	220	230	240
Available voltage range	V		198 – 264					
Running amperes	A		0.50	0.50	0.51	0.36	0.37	0.38
Power input	W		105	110	115	75	80	85
Power factor	%		95	96	94	95	94	93
Fan motor locked rotor amperes	A		1	1	1	1	1	1
FEATURES								
Controls			Microprocessor					
Timer			ON / OFF Timer (Max. 72 hr)					
Fan speeds			3 and Automatic control					
Air filter			Washable, easy access, long life (2,500 hr)					
Refrigerant control			Electronic expansion valve					
Operation sound (Hi / Me / Lo)	dB-A		43 (41)* / 36 / 33					
Refrigerant tubing connections			Flare type					
Refrigerant tube diameter	Narrow tube mm (in.)		9.52 (3 / 8)					
	Wide tube mm (in.)		12.7 (1 / 2)					
Drain connection			25 A, OD32 mm					
Drain pump			Max. head 25 cm above drain connection					
Remote Controller			Optional (RCS-SH80TG)					
Refrigerant tubing kit / Accessories			Optional / —					
Color (Approximate value)			Munsell 10Y9.3 / 0.4, RAL 9010-GL					
DIMENSIONS & WEIGHT			Indoor Unit (include panel)		Package			
					Body		Panel	
Dimensions	Height	mm (in.)	213 (8-12/32)		365 (14-12/32)		164 (6-15/32)	
	Width	mm (in.)	1,233 (48-17/32)		1,268 (49-29/32)		1,393 (54-27/32)	
	Depth	mm (in.)	730 (28-24/32)		714 (28- 4/32)		860 (33-27/32)	
Net weight	kg (lbs.)		34 (75)		—		—	
Shipping weight	kg (lbs.)		—		32 (71)		13 (29)	
Shipping volume	m ³ (cu. ft)		—		0.33 (11.7)		0.196 (6.9)	

DATA SUBJECT TO CHANGE WITHOUT NOTICE.

*: When using accessory cable

Rated conditions

Cooling: Indoor air temperature 27 °C DB / 19 °C WB, Outdoor air temperature 35 °C DB

Heating: Indoor air temperature 20 °C DB , Outdoor air temperature 7 °C DB / 6 °C WB

11. 1-Way Air Discharge Semi-concealed-Slim Type (SL Type)

Unit specifications (B)

MODEL No.	Indoor Unit		SPW-SLR123GH56					
POWER SOURCE			220 - 230 - 240 V / 1 phase / 50Hz					
PERFORMANCE			Cooling			Heating		
Capacity	kW BTU / h		3.6 12,000			4.2 14,000		
Air circulation (Hi / Me / Lo)		m ³ /h	870 (780)* / 660 / 570					
Moisture removal (High)		Liters/h	1.3			—		
ELECTRICAL RATINGS								
Voltage rating	V		220	230	240	220	230	240
Available voltage range	V		198 – 264					
Running amperes	A		0.50	0.50	0.51	0.36	0.37	0.38
Power input	W		105	110	115	75	80	85
Power factor	%		95	96	94	95	94	93
Fan motor locked rotor amperes	A		1	1	1	1	1	1
FEATURES								
Controls			Microprocessor					
Timer			ON / OFF Timer (Max. 72 hr)					
Fan speeds			3 and Automatic control					
Air filter			Washable, easy access, long life (2,500 hr)					
Refrigerant control			Electronic expansion valve					
Operation sound (Hi / Me / Lo)		dB-A	43 (41)* / 36 / 33					
Refrigerant tubing connections			Flare type					
Refrigerant tube diameter	Narrow tube mm (in.)		9.52 (3 / 8)					
	Wide tube mm (in.)		12.7 (1 / 2)					
Drain connection			25 A, OD32 mm					
Drain pump			Max. head 25 cm above drain connection					
Remote Controller			Optional (RCS-SH80TG)					
Refrigerant tubing kit / Accessories			Optional / —					
Color (Approximate value)			Munsell 10Y9.3 / 0.4, RAL 9010-GL					
DIMENSIONS & WEIGHT			Indoor Unit (include panel)		Package			
Dimensions	Height	mm (in.)	213 (8-12/32)		365 (14-12/32)		164 (6-15/32)	
	Width	mm (in.)	1,233 (48-17/32)		1,268 (49-29/32)		1,393 (54-27/32)	
	Depth	mm (in.)	730 (28-24/32)		714 (28- 4/32)		860 (33-27/32)	
Net weight		kg (lbs.)	34 (75)		—		—	
Shipping weight		kg (lbs.)	—		32 (71)		13 (29)	
Shipping volume		m ³ (cu. ft)	—		0.33 (11.7)		0.196 (6.9)	

DATA SUBJECT TO CHANGE WITHOUT NOTICE.

*: When using accessory cable

Rated conditions

Cooling: Indoor air temperature 27 °C DB / 19 °C WB, Outdoor air temperature 35 °C DB

Heating: Indoor air temperature 20 °C DB , Outdoor air temperature 7 °C DB / 6 °C WB

11. 1-Way Air Discharge Semi-concealed-Slim Type (SL Type)

Unit specifications (C)

MODEL No.	Indoor Unit		SPW-SLR183GH56					
POWER SOURCE			220 - 230 - 240 V / 1 phase / 50Hz					
PERFORMANCE			Cooling			Heating		
Capacity	kW		5.6			6.3		
	BTU / h		19,000			21,000		
Air circulation (Hi / Me / Lo)	m ³ /h		900 (810)* / 690 / 600					
Moisture removal (High)	Liters/h		2.5			—		
ELECTRICAL RATINGS								
Voltage rating	V		220	230	240	220	230	240
Available voltage range	V		198 – 264					
Running amperes	A		0.53	0.53	0.54	0.38	0.39	0.40
Power input	W		110	115	120	80	85	90
Power factor	%		94	94	93	96	95	94
Fan motor locked rotor amperes	A		1	1	1	1	1	1
FEATURES								
Controls			Microprocessor					
Timer			ON / OFF Timer (Max. 72 hr)					
Fan speeds			3 and Automatic control					
Air filter			Washable, easy access, long life (2,500 hr)					
Refrigerant control			Electronic expansion valve					
Operation sound (Hi / Me / Lo)	dB-A		44 (42)* / 38 / 33					
Refrigerant tubing connections			Flare type					
Refrigerant tube diameter	Narrow tube mm (in.)		9.52 (3 / 8)					
	Wide tube mm (in.)		15.88 (5 / 8)					
Drain connection			25 A, OD32 mm					
Drain pump			Max. head 25 cm above drain connection					
Remote Controller			Optional (RCS-SH80TG)					
Refrigerant tubing kit / Accessories			Optional / —					
Color (Approximate value)			Munsell 10Y9.3 / 0.4, RAL 9010-GL					
DIMENSIONS & WEIGHT			Indoor Unit (include panel)		Package			
					Body		Panel	
Dimensions	Height	mm (in.)	213 (8-12/32)		365 (14-12/32)		164 (6-15/32)	
	Width	mm (in.)	1,233 (48-17/32)		1,268 (49-29/32)		1,393 (54-27/32)	
	Depth	mm (in.)	730 (28-24/32)		714 (28- 4/32)		860 (33-27/32)	
Net weight	kg (lbs.)		35 (77)		—		—	
Shipping weight	kg (lbs.)		—		33 (73)		13 (29)	
Shipping volume	m ³ (cu. ft)		—		0.33 (11.7)		0.196 (6.9)	

DATA SUBJECT TO CHANGE WITHOUT NOTICE.

*: When using accessory cable

Rated conditions

Cooling: Indoor air temperature 27 °C DB / 19 °C WB, Outdoor air temperature 35 °C DB

Heating: Indoor air temperature 20 °C DB , Outdoor air temperature 7 °C DB / 6 °C WB

11. 1-Way Air Discharge Semi-concealed-Slim Type (SL Type)

Unit specifications (D)

MODEL No.		Indoor Unit		SPW-SLR253GH56			
POWER SOURCE		220 - 230 - 240 V / 1 phase / 50Hz					
PERFORMANCE		Cooling			Heating		
Capacity	kW BTU / h	7.3 25,000			8.0 27,000		
Air circulation (Hi / Me / Lo)		m ³ /h 1200 (1110)* / 990 / 780					
Moisture removal (High)		Liters/h 3.3			—		
ELECTRICAL RATINGS							
Voltage rating	V	220	230	240	220	230	240
Available voltage range	V	198 – 264					
Running amperes	A	0.55	0.55	0.56	0.40	0.41	0.42
Power input	W	115	120	125	85	90	95
Power factor	%	95	95	93	97	95	94
Fan motor locked rotor amperes	A	1	1	1	1	1	1
FEATURES							
Controls		Microprocessor					
Timer		ON / OFF Timer (Max. 72 hr)					
Fan speeds		3 and Automatic control					
Air filter		Washable, easy access, long life (2,500 hr)					
Refrigerant control		Electronic expansion valve					
Operation sound (Hi / Me / Lo)		dB-A 48 (46)* / 44 / 37					
Refrigerant tubing connections		Flare type					
Refrigerant tube diameter	Narrow tube mm (in.)	9.52 (3 / 8)*					
	Wide tube mm (in.)	15.88 (5 / 8)					
Drain connection		25 A, OD32 mm					
Drain pump		Max. head 25 cm above drain connection					
Remote Controller		Optional (RCS-SH80TG)					
Refrigerant tubing kit / Accessories		Optional / —					
Color (Approximate value)		Munsell 10Y9.3 / 0.4, RAL 9010-GL					
DIMENSIONS & WEIGHT		Indoor Unit (include panel)		Package			
Dimensions	Height	mm (in.)	213 (8-12/32)	Body		Panel	
	Width	mm (in.)	1,430 (56-10/32)	1,465 (57-22/32)		1,590 (62-19/32)	
	Depth	mm (in.)	730 (28-24/32)	714 (28- 4/32)		860 (33-27/32)	
Net weight		kg (lbs.)	39 (86)		—		—
Shipping weight		kg (lbs.)	—		35 (77)		15 (33)
Shipping volume		m ³ (cu. ft)	—		0.382 (13.5)		0.224 (7.9)

DATA SUBJECT TO CHANGE WITHOUT NOTICE.

Rated conditions

Cooling: Indoor air temperature 27 °C DB / 19 °C WB, Outdoor air temperature 35 °C DB

Heating: Indoor air temperature 20 °C DB , Outdoor air temperature 7 °C DB / 6 °C WB

* Use the "Tube connector" (accessory part with unit).

11. 1-Way Air Discharge Semi-concealed-Slim Type (SL Type)

11-2. Major component specifications

Indoor unit (A)

MODEL No.		SPW-SLR93GH56	
Source		220 - 230 - 240 V / 1 phase / 50Hz	
Controller P.C.B. Ass'y		CR-X253GH (Microprocessor)	
Fan (Number...diameter)	mm	Centrifugal (3)	
Fan motor			
Model...Nominal output	W	SR4X - 31A3P... 30 W	
Source		220 - 230 - 240 V / 1 phase / 50 Hz	
No. of pole...r.p.m. (230 V, High)	rpm.	4... 1.010	
Coil resistance (Ambient temperature 20 °C)	Ω	WHT - BRN : 191.0 WHT - VLT : 47.1 VLT - ORG : 40.0	ORG - YEL : 40.0 YEL - BLK : 96.5 BLK - PNK : 44.7
Safety device			
Operating temperature	Open °C	130 ± 8	
	Close °C	79 ± 15	
Run capacitor	VAC, μF	440 V, 1.2 μF	
Electronic expansion valve			
Solenoid control model		DKV-MOZS550E0	
Coil resistance (at 20 °C)	Ω	ORG - GRY : 46 , RED - GRY : 46,	YEL - GRY : 46 BLK - GRY : 46
Solenoid control valve model		IKV-24D12	
Heat exchanger			
Coil		Aluminum plate fin / Copper tube	
Rows...fin pitch	mm	2...1.5	
Face area	m ²	0.145	
Panel			
Model No.		PNR-SL183GHA	
Auto louver motor		MT8-3C	
Auto louver motor...Rated	V, W, rpm.	220 - 240 VAC, 3 W, 2.5 rpm	
Coil resistance (at 25 °C)	Ω	16.430 Ω ± 8 %	
Drain Pump		WP20SL-23	
Rated	V, W	AC230 V, 50 Hz, 14.7 W	
Total head & capacity		400 mm, 600 cc/min	

1

11. 1-Way Air Discharge Semi-concealed-Slim Type (SL Type)

Indoor unit (B)

MODEL No.		SPW-SLR123GH56	
Source		220 - 230 - 240 V / 1 phase / 50Hz	
Controller P.C.B. Ass'y		CR-X253GH (Microprocessor)	
Fan (Number...diameter)	mm	Centrifugal (3)	
Fan motor			
Model...Nominal output	W	SR4X - 31A3P... 30 W	
Source		220 - 230 - 240 V / 1 phase / 50 Hz	
No. of pole...r.p.m. (230 V, High)	rpm.	4... 1.080	
Coil resistance (Ambient temperature 20 °C)	Ω	WHT - BRN : 191.0	ORG - YEL : 40.0
		WHT - VLT : 47.1	YEL - BLK : 96.5
		VLT - ORG : 40.0	BLK - PNK : 44.7
Safety device			
Operating temperature	Open °C	130 ± 8	
	Close °C	79 ± 15	
Run capacitor	VAC, μF	440 V, 1.5 μF	
Electronic expansion valve			
Solenoid control model		DKV-MOZS550E0	
Coil resistance (at 20 °C)	Ω	ORG - GRY : 46	YEL - GRY : 46
		RED - GRY : 46	BLK - GRY : 46
Solenoid control valve model		IKV-24D12	
Heat exchanger			
Coil		Aluminum plate fin / Copper tube	
Rows...fin pitch	mm	2 ... 1.5	
Face area	m ²	0.145	
Panel			
Model No.		PNR-SL183GHA	
Auto louver motor		MT8-3C	
Auto louver motor...Rated	V, W, rpm.	220 - 240 VAC, 3 W, 2.5 rpm	
Coil resistance (at 25 °C)	Ω	16.430 Ω ± 8 %	
Drain Pump			
Rated		WP20SL-23	
Rated	V, W	AC230 V, 50 Hz, 14.7 W	
Total head & capacity		400 mm, 600 cc/min	

11. 1-Way Air Discharge Semi-concealed-Slim Type (SL Type)

Indoor unit (C)

MODEL No.		SPW-SLR183GH56	
Source		220 - 230 - 240 V / 1 phase / 50Hz	
Controller P.C.B. Ass'y		CR-X253GH (Microprocessor)	
Fan (Number...diameter)	mm	Centrifugal (3)	
Fan motor			
Model...Nominal output	W	SR4X - 31A3P... 30 W	
Source		220 - 230 - 240 V / 1 phase / 50 Hz	
No. of pole...r.p.m. (230 V, High)	rpm.	4... 1,080	
Coil resistance (Ambient temperature 20 °C)	Ω	WHT - BRN : 191.0	ORG - YEL : 40.0
		WHT - VLT : 47.1	YEL - BLK : 96.5
		VLT - ORG : 40.0	BLK - PNK : 44.7
Safety device			
Operating temperature	Open °C	130 ± 8	
	Close °C	79 ± 15	
Run capacitor	VAC, μF	440 V, 1.5 μF	
Electronic expansion valve			
Solenoid control model		DKV-MOZS550E0	
Coil resistance (at 20 °C)	Ω	ORG - GRY : 46 ,	YEL - GRY : 46
		RED - GRY : 46 ,	BLK - GRY : 46
Solenoid control valve model		IKV-24D12	
Heat exchanger			
Coil		Aluminum plate fin / Copper tube	
Rows...fin pitch	mm	3...1.5	
Face area	m ²	0.145	
Panel			
Model No.		PNR-SL183GHA	
Auto louver motor		MT8-3C	
Auto louver motor...Rated	V, W, rpm.	220 - 240 VAC, 3 W, 2.5 rpm	
Coil resistance (at 25 °C)	Ω	16.430 Ω ± 8 %	
Drain Pump		WP20SL-23	
Rated	V, W	AC230 V, 50 Hz, 14.7 W	
Total head & capacity		400 mm, 600 cc/min	

1

11. 1-Way Air Discharge Semi-concealed-Slim Type (SL Type)

Indoor unit (D)

MODEL No.		SPW-SLR253GH56	
Source		220 - 230 - 240 V / 1 phase / 50Hz	
Controller P.C.B. Ass'y		CR-X253GH (Microprocessor)	
Fan (Number...diameter)	mm	Centrifugal (4)	
Fan motor			
Model...Nominal output	W	SFG4X - 51B5P... 30 W	
Source		220 - 230 - 240 V / 1 phase / 50 Hz	
No. of pole...r.p.m. (230 V, High)	rpm.	4... 1,210	
Coil resistance (Ambient temperature 20 °C)	Ω	WHT - BRN : 149.8	ORG - YEL : 35.66
		WHT - VLT : 29.44	YEL - BLK : 40.72
		VLT - ORG : 23.39	BLK - PNK : 3.780
Safety device			
Operating temperature	Open °C	130 ± 8	
	Close °C	79 ± 15	
Run capacitor	VAC, μF	440 V, 2.0 μF	
Electronic expansion valve			
Solenoid control model		DKV-MOZS550E0	
Coil resistance (at 20 °C)	Ω	ORG - GRY : 46 ,	YEL - GRY : 46
		RED - GRY : 46 ,	BLK - GRY : 46
Solenoid control valve model		IKV-24D12	
Heat exchanger			
Coil		Aluminum plate fin / Copper tube	
Rows...fin pitch	mm	3 ... 1.5	
Face area	m ²	0.170	
Panel			
Model No.		PNR-SL253GHA	
Auto louver motor		MT8-3C	
Auto louver motor...Rated	V, W, rpm.	220 - 240 VAC, 3 W, 2.5 rpm	
Coil resistance (at 25 °C)	Ω	16.430 Ω ± 8 %	
Drain Pump			
Rated		AC230 V, 50 Hz, 14.7 W	
Total head & capacity		400 mm, 600 cc/min	

11. 1-Way Air Discharge Semi-concealed-Slim Type (SL Type)

11-3. Other component specifications

MODEL NO.	Indoor Unit	SPW-SLR93 ~ 253GH56	
Power Transformer		ATR-II215TB	
Rated			
Primary	V, Hz	AC 230 V, 50 Hz	
Secondary		10.2 V, 1.4 A	
		14 V, 0.5 A	
Coil resistance	Ω	WHT - WHT : 112 RED - RED : 2.3	BRN - BRN : 0.5
Thermal cut off temperature	$^{\circ}\text{C}$	150	
Thermistor (Coil sensor)		PB3M-41E-S4 , PBC-41E-S25 , PBC-41E-S36	
Resistance	K Ω	-10 $^{\circ}\text{C}$: 23.7 \pm 5 % , 20 $^{\circ}\text{C}$: 6.5 \pm 5 % -5 $^{\circ}\text{C}$: 18.8 \pm 5 % , 30 $^{\circ}\text{C}$: 4.4 \pm 5 % 0 $^{\circ}\text{C}$: 15.0 \pm 5 % , 40 $^{\circ}\text{C}$: 3.1 \pm 5 % 5 $^{\circ}\text{C}$: 12.1 \pm 5 % , 45 $^{\circ}\text{C}$: 2.6 \pm 5 % 10 $^{\circ}\text{C}$: 9.7 \pm 5 %	
Thermistor (Room or coil sensor)		KTEC-35-S6	
Resistance	K Ω	0 $^{\circ}\text{C}$: 16.5 \pm 5 % , 40 $^{\circ}\text{C}$: 2.7 \pm 5 % 5 $^{\circ}\text{C}$: 12.8 \pm 5 % , 45 $^{\circ}\text{C}$: 2.2 \pm 5 % 10 $^{\circ}\text{C}$: 10.0 \pm 5 % , 50 $^{\circ}\text{C}$: 1.8 \pm 5 % 20 $^{\circ}\text{C}$: 6.3 \pm 5 % , 55 $^{\circ}\text{C}$: 1.5 \pm 5 % 30 $^{\circ}\text{C}$: 4.0 \pm 5 %	
Electronic expansion valve			
Valve body		IKV-24D12	
Coil		DKV-MOZS550E0	
Drain pump		WP20SL-19	
Rated		AC 230 V, 14.7 W	
Float switch		FS-0218-103	
Rated (Contact rated)		DC 12 V, 25 W	

1

11. 1-Way Air Discharge Semi-concealed-Slim Type (SL Type)

11-4. Dimensional data

Indoor unit : 9, 12, 18, 25 Type

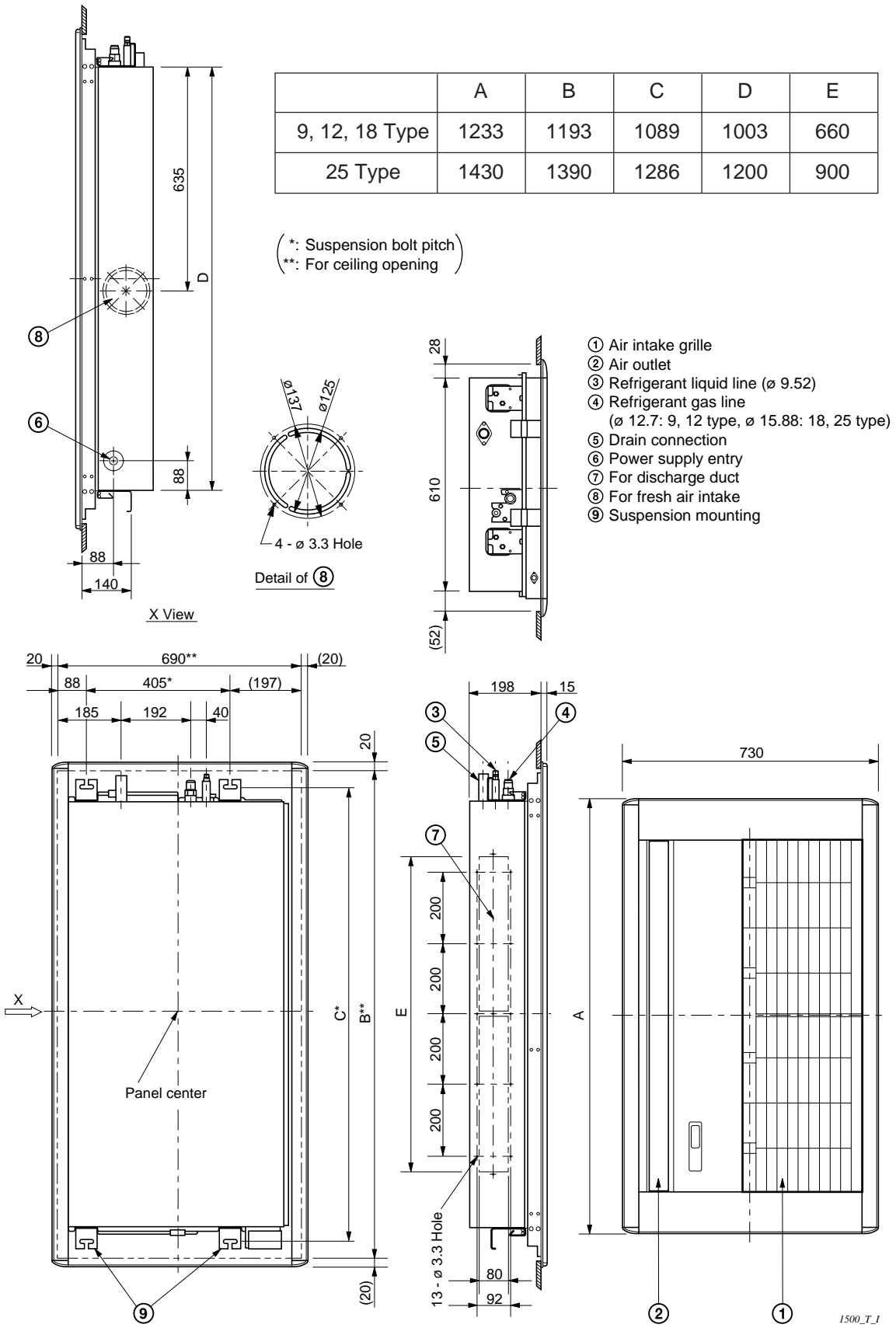

11. 1-Way Air Discharge Semi-concealed-Slim Type (SL Type)

11-5. Noise criterion curves

MODEL : SPW-SLR93GH56, SLR123GH56
 SOUND LEVEL : HIGH 43 dB(A), NC 41 / LOW 33 dB(A), NC 27
 (HIGH 41 dB(A), NC 37 / LOW 33 dB(A), NC 27)
 () : when Booster cable connected
 CONDITION : Under the unit 1.5 m
 SOURCE : 220 - 230 - 240 V, 1 Phase, 50 Hz

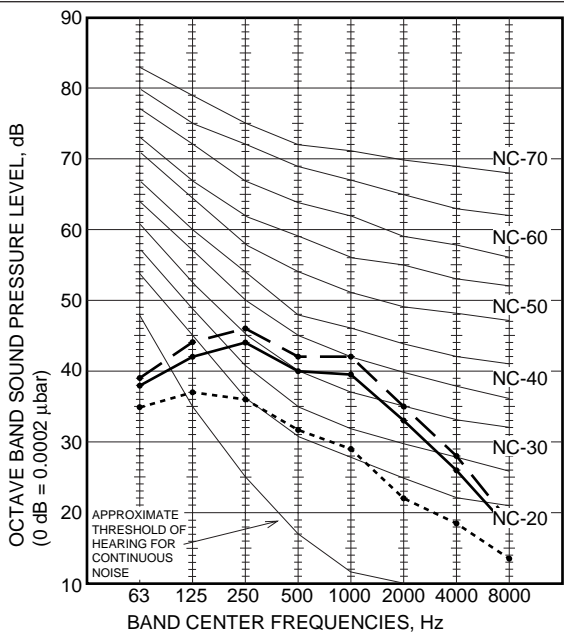

MODEL : SPW-SLR183GH56
 SOUND LEVEL : HIGH 44 dB(A), NC 41 / LOW 35 dB(A), NC 29
 (HIGH 42 dB(A), NC 38 / LOW 35 dB(A), NC 29)
 () : when Booster cable connected
 CONDITION : Under the unit 1.5 m
 SOURCE : 220 - 230 - 240 V, 1 Phase, 50 Hz

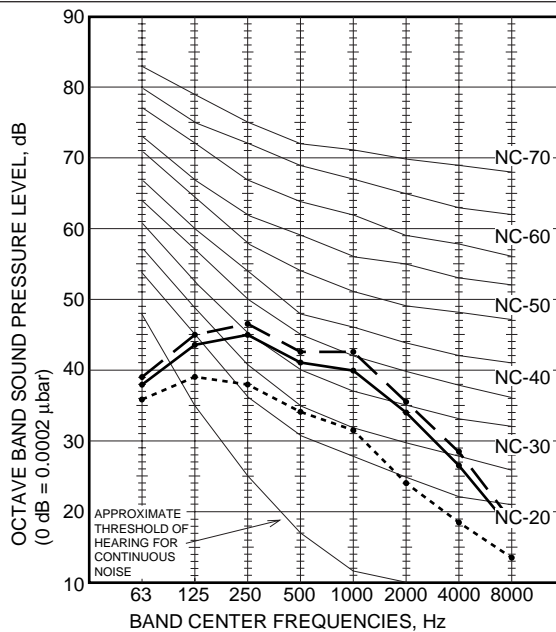

MODEL : SPW-SLR253GH56
 SOUND LEVEL : HIGH 48 dB(A), NC 41 / LOW 37 dB(A), NC 30
 (HIGH 46 dB(A), NC 38 / LOW 37 dB(A), NC 30)
 () : when Booster cable connected
 CONDITION : Under the unit 1.5 m
 SOURCE : 220 - 230 - 240 V, 1 Phase, 50 Hz

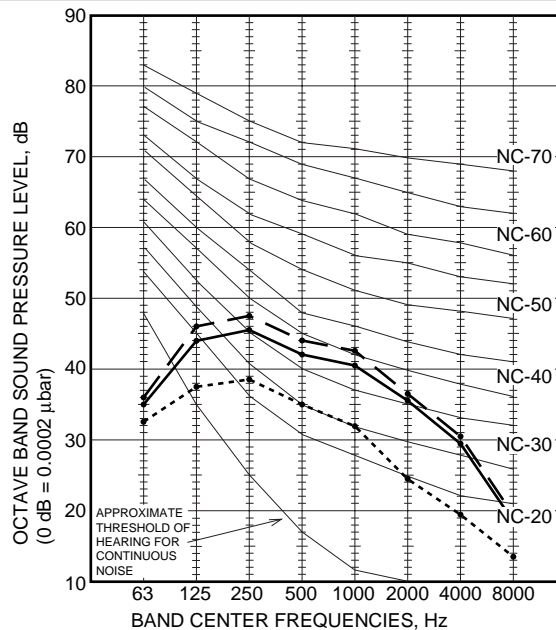

11. 1-Way Air Discharge Semi-concealed-Slim Type (SL Type)

11-6. Air throw distance chart

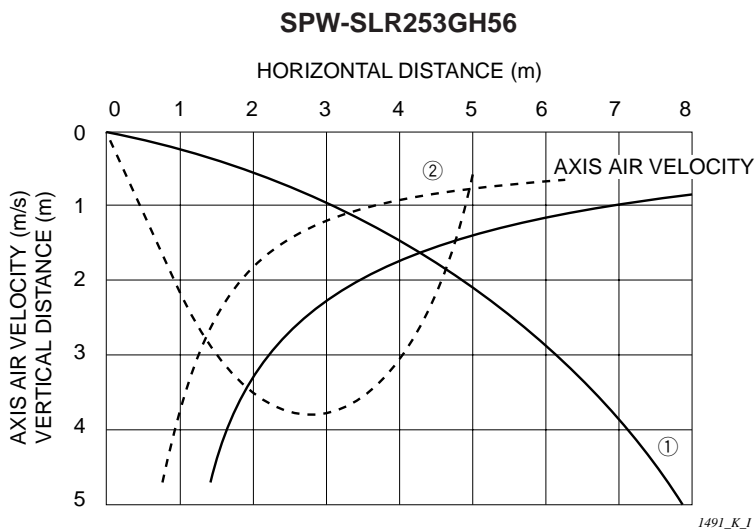
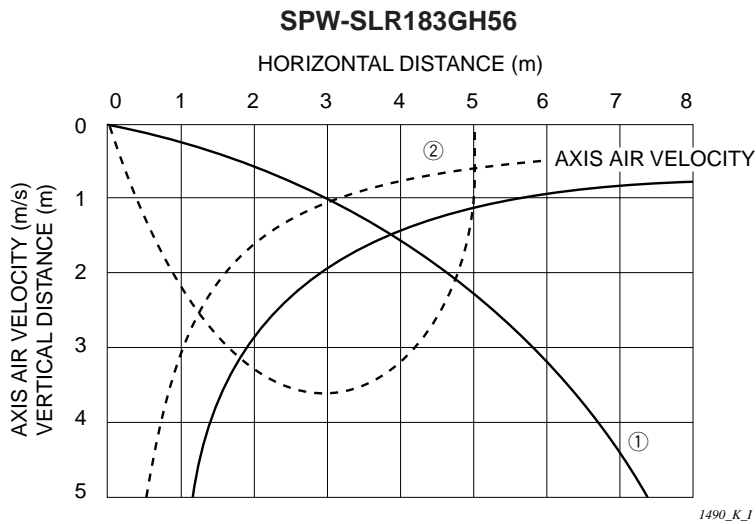
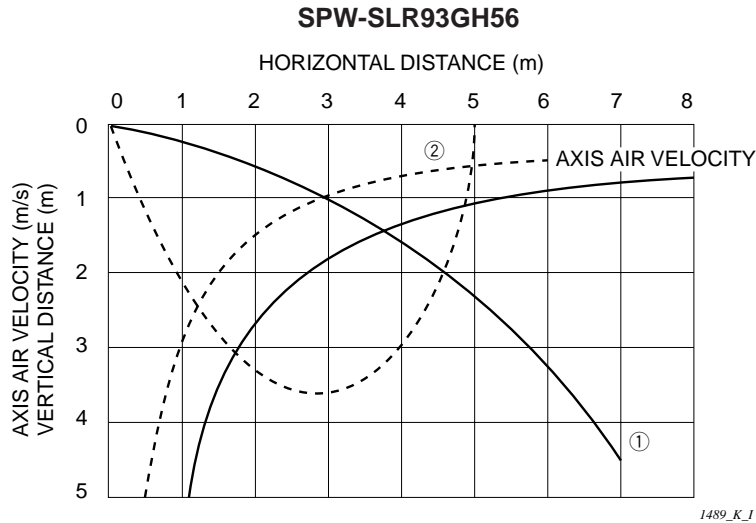

Condition Fan Speed : Hi
 Room air temp. : 27 °C DB in cooling mode
 20 °C DB in heating mode

①: LOUVER ANGLE 15° in cooling mode
 ②: LOUVER ANGLE 65° in cooling mode

Contents

2. Processes and Functions

1. Compressor Control	II - 2
1-1. Compressor capacity control	II - 2
1-2. Protection control	II - 4
2. Reverse Cycle Defrosting	II - 6
2-1. Frost detection	II - 6
2-2. Defrost execution condition	II - 6
2-3. Defrost end conditions	II - 6
3. Reverse Cycle Starting Control	II - 7
4. Outdoor Fan Control	II - 7
5. 4-way Valve Switching Control	II - 7
6. Save Valve Control	II - 7
7. Outdoor Electronic Control Valve	II - 8
8. Liquid Valve Control	II - 8
9. Room Temperature Control	II - 9
10. Auto. Mode for Automatic Heating/Cooling Switching	II -10
11. Heating Preparations	II -11
12. Dehumidifying Control	II -12
13. Automatic Fan Speed Control	II -12
13-1. Cooling	II - 12
13-2. Heating	II - 12
14. Auto-flap Control	II -13
14-1. X, S, T Type	II - 13
14-2. K Type	II - 13
15. Drain Pump Control	II -14
16. Indoor Electronic Control Valve	II -14
16-1. Cooling and dehumidifying operation	II - 14
16-2. Heating operation	II - 14
17. Discharge Temperature Control (Only for U, D Type)	II -15
18. Automatic Restart Function after Power Failure	II -15
19. Filter Sign	II -15

1. Compressor Control

1-1. Compressor capacity control

(1) Compressor usage by model

Outdoor unit capacity	28 kw outdoor unit		22.4 kw outdoor unit	
Type of compressor	P/C compressor	AC compressor	P/C compressor	AC compressor
Compressor capacity	14 kw	14 kw	11.2 kw	11.2 kw

P/C compressor : Power control compressor

AC compressor : Constant speed compressor

(2) Compressor capacity control

The compressor capacity control is achieved by switching on and off the P/C compressor, AC compressor, low-pressure valve (No. 1, 2, 3) high-pressure valve, and external save valve following the current capacity obtained through the calculation procedure below.

- Serial capacity calculation (calculated from indoor unit capacity with thermo-on and the difference between temperature setting and room temperature)
- ↓
- Aid-capacity calculation (Calculation from operating condition)
- ↓
- Upper limit capacity (= serial capacity + aid-capacity)
- ↓
- Calculation of current capacity (protective control, etc., added)
- ↓
- The compressor magnetic contactor (52 C), low-pressure valve (No. 1, 2, 3) , high-pressure valve, and save valve output are set according to the current capacity.
Occasionally, some special-purpose control is added.

(3) Relationship between current capacity and outputs

① 50 Hz 22.4 kw outdoor unit (SPW-CR703GVH8, SPW-CR703GV8)

Current capacity (kw)		0	1.4	2.8	4.2	5.6	7	8.4	9.8	11.2
11.2 kw compressor (P/C)	52C	OFF	ON	ON	ON	ON	ON	ON	ON	ON
	High-pressure valve	OFF	OFF	OFF	ON	ON	ON	ON	ON	ON
	Low-pressure valve 1	ON	ON	ON	OFF	OFF	ON	ON	ON	ON
	Low-pressure valve 2	ON	ON	ON	ON	ON	OFF	OFF	ON	ON
	Low-pressure valve 3	ON	ON	ON	ON	ON	ON	ON	OFF	OFF
11.2 kw compressor (AC)		OFF	OFF	OFF	OFF	OFF	OFF	OFF	OFF	OFF
External save valve		ON	ON	OFF	ON	OFF	ON	OFF	ON	OFF

Current capacity (kw)		12.6	14	15.4	16.8	18.2	19.6	21	22.4
11.2 kw compressor (P/C)	52C	ON	ON	ON	ON	ON	ON	ON	ON
	High-pressure valve	OFF	OFF	ON	ON	ON	ON	ON	ON
	Low-pressure valve 1	ON	ON	OFF	OFF	ON	ON	ON	ON
	Low-pressure valve 2	ON	ON	ON	ON	OFF	OFF	ON	ON
	Low-pressure valve 3	ON	ON	ON	ON	ON	ON	OFF	OFF
11.2 kw compressor (AC)		ON	ON	ON	ON	ON	ON	ON	ON
External save valve		ON	OFF	ON	OFF	ON	OFF	ON	OFF

② 50 Hz 28 kw outdoor unit (SPW-CR903GVH8, SPW-CR903GV8)

Current capacity (kw)		0	1.75	3.5	5.25	7	8.75	10.5	12.25	14
14 kw compressor (P/C)	52C	OFF	ON	ON	ON	ON	ON	ON	ON	ON
	High-pressure valve	OFF	OFF	OFF	ON	ON	ON	ON	ON	ON
	Low-pressure valve 1	ON	ON	ON	OFF	OFF	ON	ON	ON	ON
	Low-pressure valve 2	ON	ON	ON	ON	ON	OFF	OFF	ON	ON
	Low-pressure valve 3	ON	ON	ON	ON	ON	ON	ON	OFF	OFF
14 kw compressor (AC)		OFF	OFF	OFF	OFF	OFF	OFF	OFF	OFF	OFF
External save valve		ON	ON	OFF	ON	OFF	ON	OFF	ON	OFF

Current capacity (kw)		15.75	17.5	19.25	21	22.75	24.5	26.25	28
14 kw compressor (P/C)	52C	ON	ON	ON	ON	ON	ON	ON	ON
	High-pressure valve	OFF	OFF	ON	ON	ON	ON	ON	ON
	Low-pressure valve 1	ON	ON	OFF	OFF	ON	ON	ON	ON
	Low-pressure valve 2	ON	ON	ON	ON	OFF	OFF	ON	ON
	Low-pressure valve 3	ON	ON	ON	ON	ON	ON	OFF	OFF
14 kw compressor (AC)		ON	ON	ON	ON	ON	ON	ON	ON
External save valve		ON	OFF	ON	OFF	ON	OFF	ON	OFF

1. Compressor Control

(4) Special control of compressor.

- Operation of the P/C compressor
When current capacity is not 0, the compressor does not stop.
- AC compressor start delay (for outdoor units)
When two compressors are to be started, the AC compressor is started 15 seconds after the P/C compressor.
(22.4 kw, 28 kw outdoor units)
- For compressors, when a compressor is stopped, it is not restarted for 3 minutes. During this period, the current capacity does not increase. However, stops before and after reverse-cycle starting and reverse-cycle defrosting are excluded from this rule.
- When the AC compressor starts while the P/C compressor is working, current capacity is set as minimum capacity for 30 seconds and the AC compressor is started. (22.4 kw and 28 kw outdoor units)
- The above mentioned control takes precedence over all other control.
- Speed on current capacity increase
The microcomputer selects the optimum value for the speed at which the current capacity increases according to the operating conditions. In the fastest case, the current capacity immediately increases to the maximum; in the slowest case, the current capacity increases at 1 step / 60 seconds.

1. Compressor Control

1-2. Protection control

(1) Main principles

If the current capacity decreases, it does not increase again for 3 minutes.

(2) Evaporation temperature control (Freeze prevention)

- ① Of the E1 and E2 indoor coil temperature of all the thermo-on indoor unit operating in cooling mode. The lowest is taken as the minimum evaporation temperature (=Te) and the control indicated below is performed every 30 seconds.

Minimum evaporation temperature (Te)	Control
↑ 5.5 °C	Current capacity increase allowed
5.0 °C 1.5 °C	Current capacity increase inhibited
1.0 °C ↓	Current capacity decreases 1 step

- ② When TEST RUN selected for even one of the indoor units operating in cooling mode, the current capacity is always allowed to increase.
- ③ For 3 minutes after the compressor start, the “current capacity decrease 1 step” is the “current capacity increase inhibited”.
- ④ At the minimum current capacity, if evaporation temperature control requires further current capacity decrease, it is treated as current capacity increase inhibited for 10 minutes and the unit does not thermo-off.

(3) Condensation temperature control

- ① Of the E1 and E2 indoor coil temperatures of all the connected indoor units, the highest is taken as the maximum condensing temperature (=Tc) and the control in the table below is performed. This control is performed every 15 seconds.

Note : The value N is changed 60~63 °C according to operating condition. (Normally 63 °C)

Minimum condensation temperature (Tc)	Control
↑ N + 0.5 °C	Thermo-off
N 57.5 °C	Current capacity decreases 1 step
57.0 °C 50.0 °C	Current capacity increase inhibited
49.5 °C ↓	Current capacity increase allowed

- ② At the minimum current capacity, if condensation temperature control is on “current capacity decreases 1 step”, it is treated as “current capacity increase inhibited” for 10 minutes and the unit does not thermo-off (10-minute timer). When this 10 minutes is up, if the condensation temperature control is still on “current capacity decreases 1 step”, the unit will thermo-off. However, if the maximum condensation temperature is N + 0.5 °C or higher, the unit stops operation immediately. The 10-minute timer is cleared if the control is moved into any area other than “current capacity decreases 1 step” or if all the compressors are stopped.

1. Compressor Control

Note 1 : When heating, if outdoor fan \neq H , “current capacity increase allowed” is treated as “current capacity increase inhibited”.

Note 2 : If the compressor maximum discharge temperature ≥ 100 °C (Liquid valve is ON), the “current capacity increase allowed” is treated as “current capacity increase inhibited”.

(4) Compressor discharge temperature protection control

When the discharge temperature of the P/C compressor is excessively increased (to around 108 °C), the AC compressor stops if it is working at the same time; if the AC compressor is stopped, thermo-off or alarm message appears. When the discharge temperature of the AC compressor is excessively increased (to around 108 °C), the AC compressor stops. For each of the compressors, if the unit thermo-off 4 times to due discharge temperature protection control within 5 minutes of starting, alarm message appears.

(5) Compressor current control

The current for the 2 compressors is controlled separately.

① Lock current control

If the current for an operating compressor increases to above the corresponding value in the table below, an alarm message appears.

Compressor capacity	Lock current
50 Hz, 11.2 kw compressor	14.7 A
50 Hz, 14 kw compressor	20.4 A

② Overload current

If the current for an operating compressor remains above the corresponding value in the below table for 30 seconds, an alarm message appears.

Compressor capacity	Lock current
50 Hz, 11.2 kw compressor	12.3 A
50 Hz, 14 kw compressor	17.1 A

(6) Warm up operation control

In initial operation after microcomputer initialization, and after reverse-cycle start control (explained in Section 3) and 4-way valve switching control (explained in Section 5), the AC compressor occasionally takes as long as 20 minutes to start.

(7) Outdoor liquid temperature control in cooling (High-pressure control)

- ① Each area is monitored constantly, and if control moves into the thermo-off area, the unit thermo-off immediately. For the capacity decrease area, if it has been decreased once, it is not decreased again for 30 seconds.
- ② This control is not performed during test operation.
- ③ Even if thermo-off, this control does not result in an alarm.

Outdoor heat exchange liquid temperature	Control
↑ 60 °C	Thermo-off
59 °C	Current capacity decrease 3 steps
58 °C 57 °C	Current capacity increase inhibited
56 °C ↓	Current capacity increase allowed

2. Reverse Cycle Defrosting

- Defrost is accomplished through a reverse-cycle operation.
- During defrost operation, the outdoor fan is stopped and the indoor fan is either stopped or run at L or LL.

2-1. Frost detection

- (1) Frost is not monitored for the first 1 minutes of operation.
- (2) The frost detection conditions are:
 - Condition 1 = heat exchanger liquid temp. is 8 minutes continuously below the L2 line
 - Condition 2 = heat exchanger liquid temp. is 60 minutes, cumulative, below the L1 line

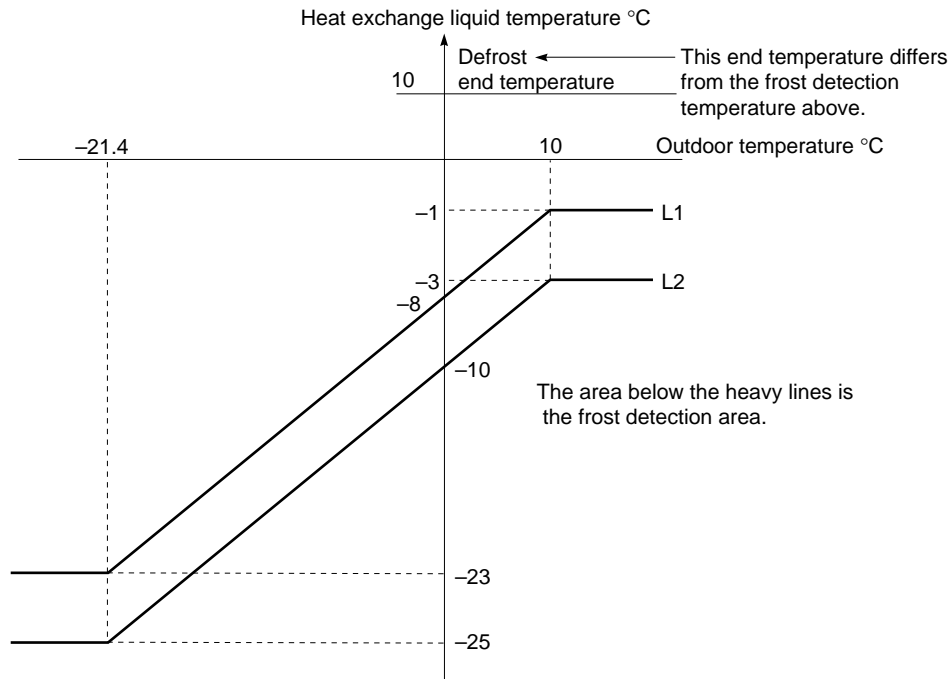

1245_M_1

2-2. Defrost execution condition

- (1) 35 minutes or more, cumulative, for heating operation. (The cumulative time differs depending on the outside air temperature and the maximum condensing temperature.)

2-3. Defrost end conditions

- (1) Outdoor heat exchanger liquid temperature ≥ 10 °C
- (2) Defrost operation is 12 minutes maximum.
- (3) Reverse-cycle defrost control

Control sections	Operation of each control section in defrosting		
	One minute before defrosting	During reverse-cycle operation (12 minutes max.)	One minute after completion of defrosting
P/C compressor	OFF	Compressor capacity control	OFF
AC compressor	OFF	↑	OFF
4-way valve	ON	OFF	ON
Outdoor fan	STOP	STOP	H
Low-pressure valve 1, 2, 3	ON	Compressor capacity control	ON
High-pressure valve	OFF	↑	OFF
Save valve	ON	Save valve control	ON
Outdoor electronic expansion valve	0 pulses	480 pulses	0 pulses

3. Reverse Cycle Starting Control

At the start of heating operation, the cooling cycle operates for 50 seconds. During this time, the outdoor and indoor fans are stopped.

Reverse-Cycle start conditions:

- (1) When starting heating operation after 60 minutes of stop operation
- (2) When starting heating operation for the first time after turning on the power
- (3) Reverse-cycle start control details
After 50 seconds of reverse-cycle (cooling) operation, the outdoor unit stops for 20 seconds, then starts normal operation.

Control sections	Operation of each control section when heating operation starts	
	Reverse-cycle operation time 50 seconds	Stop time 20 seconds
P/C compressor	Compressor capacity control	OFF
AC compressor	↑	OFF
4-way valve	OFF	ON
Outdoor fan	STOP	H
Low-pressure valve 1, 2, 3	Compressor capacity control	ON
High-pressure valve	↑	OFF
Save valve	Save valve control	ON
Outdoor electronic control valve	480 pulses	0 pulses

4. Outdoor Fan Control

- (1) Outdoor fan mode

Mode	Fan
3	H
2	M
1	L
0	STOP

- (2) Initial control

For the first 30 seconds after operation starts, outdoor fans are controlled according to the outdoor temperature as shown below.

When the fans are started, they rotate at high speed for 12 seconds.

Cooling		Heating	
Outdoor temperature		Outdoor temperature	
↑		↑	
16	H (M)	21	H (M · L · STOP)
0	H (M, L)	16	H (M · L)
	L (STOP)		H (M)

* The outdoor fans rotate at the mode in the parentheses () according to the operating capacity.

- (3) The fan mode is then switched up or down according to the operating conditions.

5. 4-way Valve Switching Control

- (1) In normal operation, the 4-way valve is off for cooling and on for heating.
- (2) When the outdoor unit is stopped while in heating mode, 60 minutes elapse and the 4-way valve goes OFF. (Energy saving)

6. Save Valve Control

- (1) The save valve is switched on according to the tables shown in Section 1. "Compressor Control."
- (2) The save valve is on when the outdoor unit is stopped. (This is due to pressure balance.)

7. Outdoor Electronic Control Valve

- (1) When the outdoor unit stops in cooling mode: 480 pulses
When the outdoor unit stops in heating mode: 0 pulses
- (2) In cooling operation mode: 480 pulses

In heating operation mode: control of degree of superheating ($\Delta T = \text{gas temperature} - \text{liquid temperature}$) of the heat exchanger

- ΔT should be 2 to 6 deg (that can be changed depending on the operation capacity).
- Control range: 75 to 480 pulses

SPW-CR903GVH8		SPW-CR703GVH8	
Current capacity (kw)	Set ΔT (deg)	Current capacity (kw)	Set ΔT (deg)
or more 25.2 kw	3	or more 22.4 kw	2
19.6~25.2 kw	4	16.8~22.4 kw	3
14~19.6 kw	5	11.2~16.8 kw	4
less than 14 kw	6	less than 11.2 kw	6

8. Liquid Valve Control

- (1) This controls the compressor discharge temperature as shown in the right diagram.
- (2) Liquid valve is OFF when in defrosting mode.

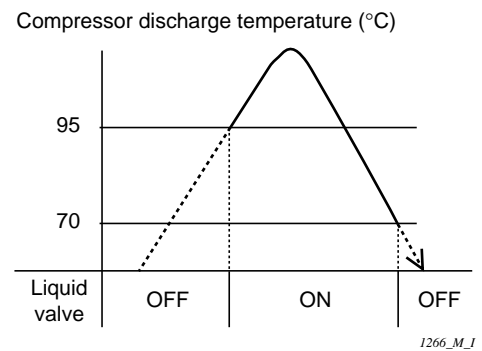

9. Room Temperature Control

The thermostat is switched on/off by ΔT as follows.

$\Delta T = (\text{Room temperature}) - (\text{Set temperature})$	
Remote control sensor	Room temperature = remote control sensor detection temperature
Body sensor	Room temperature = (Body sensor detection temperature) - (Air-intake shift temperature*)

* Shift temperature (valid only for heating)

In heating mode, a temperature difference occurs between the upper part and lower part of a room. The value is set in consideration of the difference between the temperature detected by the body sensor located in the upper part of the room and the temperature detected in the lower part of the room.

0 °C ~ 10 °C can be selected with the remote controller simple setting mode.

(Factory settings: floor standing type ----- 0 deg; wall-mounted type ----- 2 deg; other types ----- 4 deg)

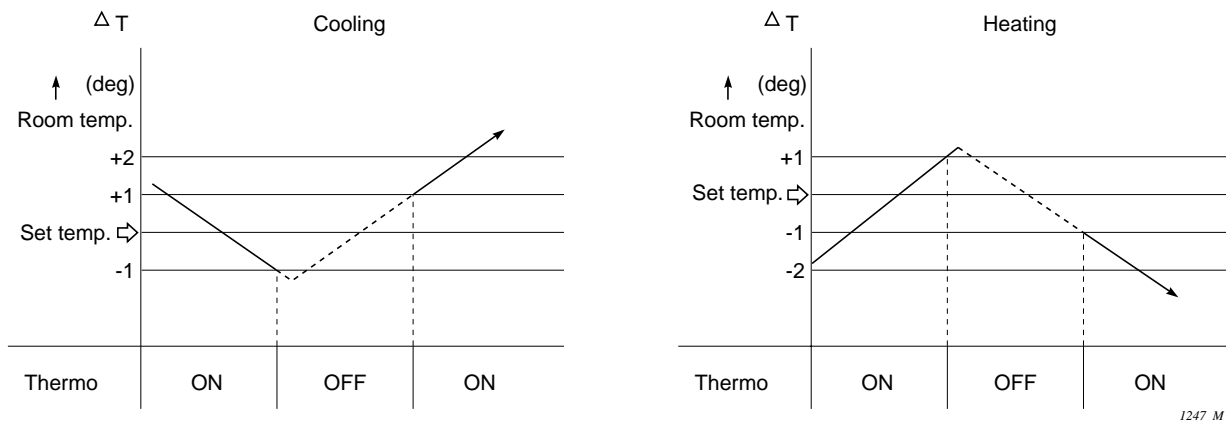

Supplement:

- (1) After thermo-on, it will not thermo-off for 3 minutes due to ΔT .
However, for heating, if the indoor coil E2 temperature ≥ 64 °C, it will thermo-off within 3 minutes (over load protection).
- (2) After thermo-off, it will not thermo-on for 1~3 minute.
For cooling or dehumidifying, it will not thermo-on if the indoor coil E1 or E2 temperature < 6 °C even after the above-mentioned period of time has passed.
- (3) When the system is set for test operation, it will not thermo-off for 60 minutes (forced thermo-on).

10. Auto. Mode for Automatic Heating/Cooling Switching

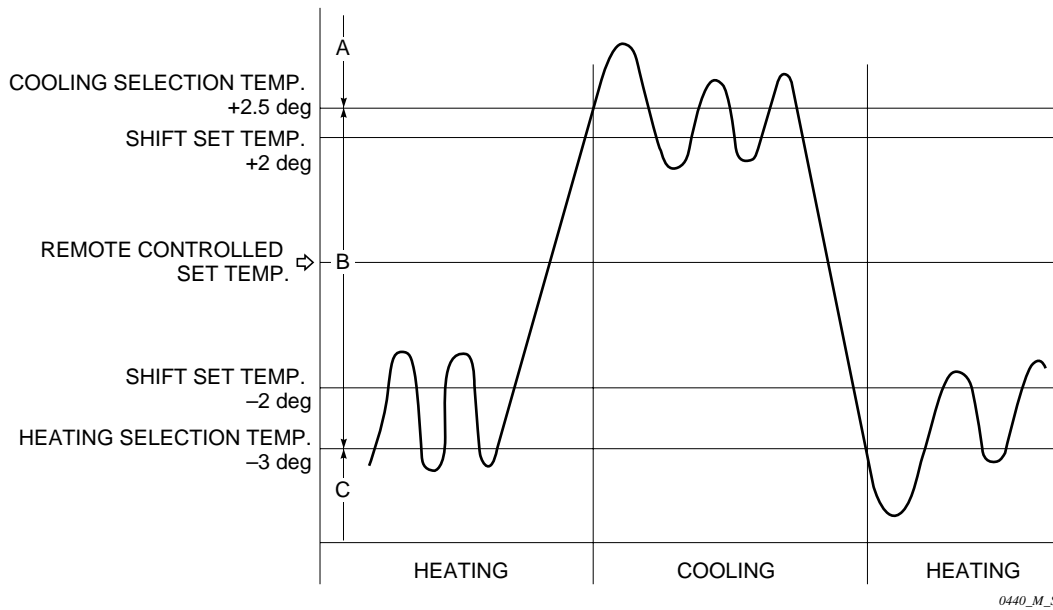
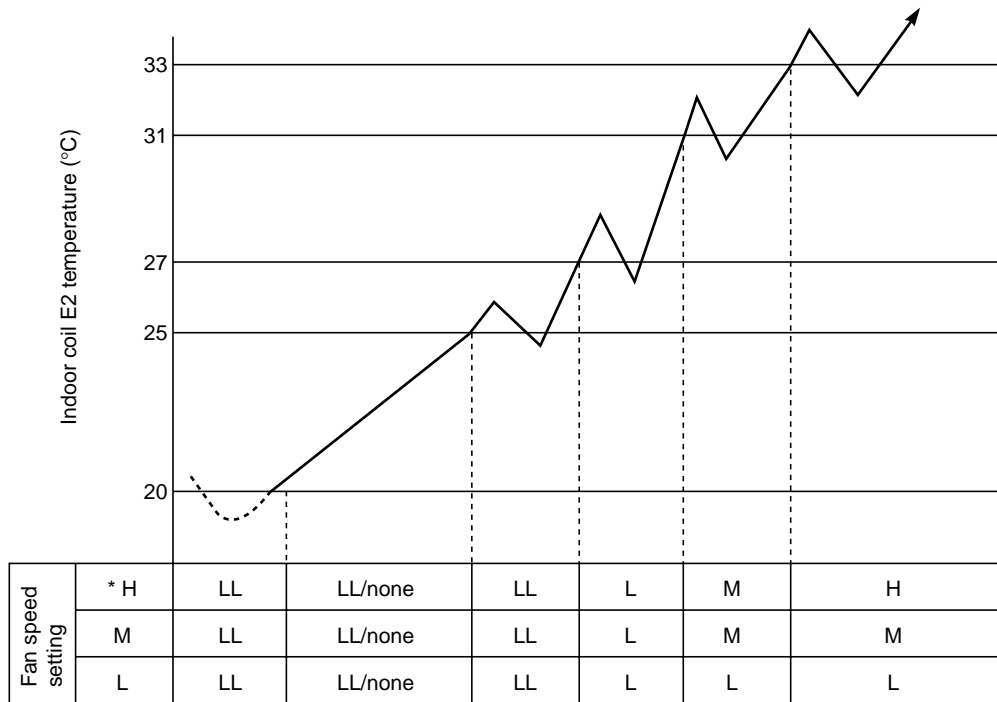

Chart summary and Explanations

- This control is effective only for one indoor unit or group control.
- (1) This chart shows how the Operation Mode (**COOLING** or **HEATING**) is determined by the microprocessor taking the room temperature into consideration. It also shows the temperature points at which the cooling or heating mode is switched, when the AUTO mode is selected.
 - (2) After operation starts, the set temperature shifts automatically by +2 deg. at cooling and by - 2 deg. at heating. For example, if cooling is selected, the set temperature changes from 20° C to 22° C.
(The display of the remote controller remains 20° C.)
 - (3) The change of the operation mode (heating to cooling, cooling to heating) by the change of the room temperature during the operation is as follows.
Heating to Cooling; Room temp. \geq Shifted temp + 0.5 deg.
Cooling to Heating; Room temp. \leq Shifted temp -1.0deg.
For example, if the room temperature rises above 22.5 °C (=22+0.5) during the cooling operation at the room temperature 20° C set by the remote controller, the operation changes to cooling. When the room temperature lowers below 17° C (=18-1.0) thereafter, the operation changes to heating again.
 - (4) In heating operation, using the body sensor, room temperature control is designed so that room air temp. is sensed as 4 deg. lower than suctioned air at indoor unit taking into account of the temperature gap between upper part and lower part of the room.
Accordingly, in this example, when the body sensor detection temperature reaches more than 26.5 °C, the operation is changed from heating to cooling.
 - (5) Within 10 minutes after the compressor turns OFF, the operation does not change to cooling (heating), even when the room temperature changes from C to A (A to C).
 - (6) When switching from cooling (heating) to heating (cooling), the actuation of the 4 way valve will delay about 30-50 seconds after the compressor turns ON.

11. Heating Preparations

- (1) After thermo.-on, until the set fan speed is reached, cool air is output (emanates) from this beginning heating operation and the indoor fan speed is controlled as shown below to prevent cold draft.
- When the fan speed is LL or off, "STAND BY" is displayed at the remote controller.
 - Room temperature thermostat off
 - Condensation elimination operation
 - After heating operation start, until the indoor coil E2 temperature is 27 °C or higher (6 minutes max.)
 - After heating operation start, the fan speed approaches the set fan speed as the indoor coil E2 temperature rises.



H: High L : Low
M: Middle LL: Very low

* Same for automatic fan speed setting

- The dotted lines are fan off. (When the indoor coil E2 temperature is 20°C or lower, the fan does not operate.)

0322_M_1

- (2) Fan speed control after set fan speed is reached
- Indoor coil E2 temperature ≥ 43 °C, the control below is performed.
 - Indoor coil E2 temperature ≤ 38 °C, until indoor coil E2 temperature ≥ 43 °C, the fan speed accelerates in a rising slope.
 - When the fan speed changes, it does not change again for 1 minute.

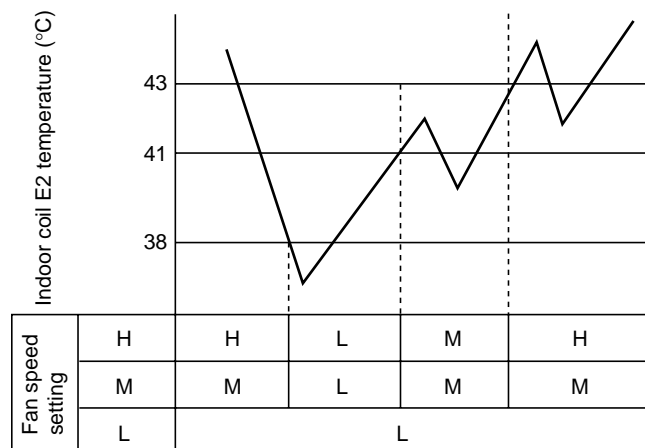

H: High L : Low
M: Middle LL: Very low

0323_M_1

12. Dehumidifying Control

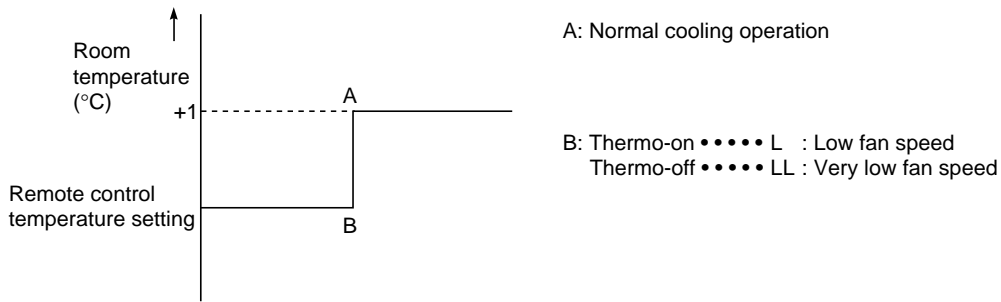

1268_M_I

13. Automatic Fan Speed Control

- (1) When automatic fan speed is selected with the remote controller, the indoor fan motor is controlled as shown below.
- (2) The fan speed does not change in 3 minutes of cooling operation and in one minute of heating operation after operation starts.

11-1. Cooling

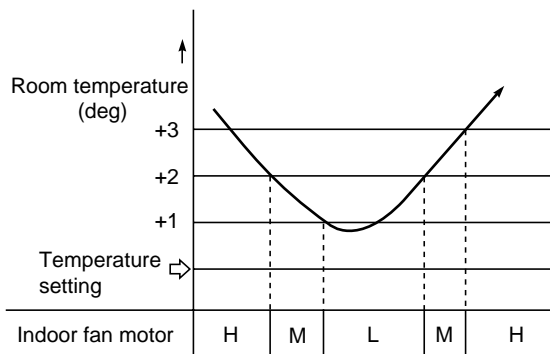

H : High L : Low
 M : Middle LL : Very low

0324_M_I

11-2. Heating

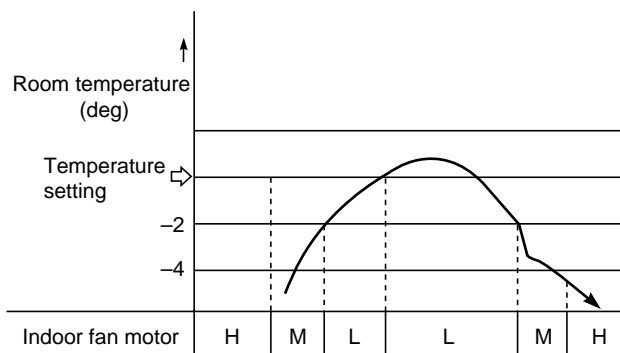

H : High L : Low
 M : Middle LL : Very low

0325_M_I

14. Auto-flap Control

14-1. X, S, T Type

The auto-flap controls the air flow to one of the five vertical levels.

X type (4-way), S type (2-way)

T type

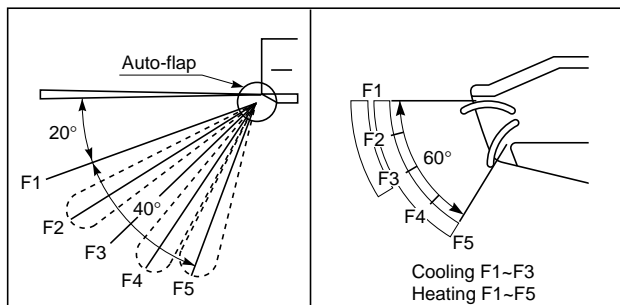

1267_M_1

Operation mode	Flap position	
	Automatic setting	Manual setting
Cooling / drying	F2	F1 · F2 · F3 · swing
Fan	F2	F1 · F2 · F3 · F4 · F5 · swing
Heating	F4	F1 · F2 · F3 · F4 · F5 · swing
Heating preparation	F2 (Original position after release)	

- (1) When the unit is stopped, the auto-flap returns to the F5 position.
- (2) When the airflow direction is set manually (optional setting), the auto and swing settings will be released. To return to automatic airflow direction, change the operation mode.
- (3) Once auto-flap is set, it is input into the microcomputer memory.
- (4) When the operation mode is changed, the unit begins a sensing operation. (If a search for sensing points does not succeed in one minute, only the flap moves.)

Remote controller configuration	Wired remote controller (RCS-SH80TG)		Wireless remote controller (RCS-SH80TGWL)		System controller (SHA-KC64TG)
	Single	Group control	Single	Group control	
Auto-flap					
Swing	○	○	○	○	△ (*1)
Air direction setting	○	○	○	○	△ (*1)

*1: Only possible when remote control unit is not used.
For group control, the settings are for the complete group.

14-2. K Type

When the "SWEEP" button is pressed, swing starts and when it is pressed again, the flap stops in place.

15. Drain Pump Control (Does not include K, T, D, F, FM Type)

- (1) Drain pump control turns ON when the compressor is activated in cooling operation.
- (2) When the compressor turns OFF due to freeze prevention control, drain pump turns ON for 20 minutes.
- (3) Drain pump control turns ON when the floating switch is activated. If the operation is performed for 5 minutes and the floating switch does not return to the original position, an alarm message P10 is displayed. (Operation continues.)

If the floating switch returns to the original position, control turns OFF 5 minutes after the return of the floating switch.

16. Indoor Electronic Control Valve

- However, when the compressor is stopped, there still occur 20 pulses. When the power is first switched on until the ON / OFF operation button is pressed, the valve is open at 480 pulses.
- From then on, control is accomplished as shown below.

16-1. Cooling and dehumidifying operation

- (1) When operation is stopped and thermo-off, operation is still at 20 pulses. However, the electronic control valve may be opened for about 3 minutes to recover oil in the pipes.
- (2) When the thermostat is active, the valve is controlled in the range of 70 to 480 pulses.
- (3) When the compressor maximum discharge temperature ≥ 98 °C, the degree of electronic control valve opening increases.
- (4) When the super-heat of indoor unit (E3 temperature – E1 temperature) is low, the degree of electronic control valve opening is reduced. However, (3) has priority.
- (5) When the super-heat at the indoor unit outlet is high, the degree of the electronic control valve opening increases.

16-2. Heating operation

- (1) When operation is stopped and the thermostat is inactive, the electronic expansion valve opens and closes so that the refrigerant does not accumulate excessively in the indoor unit.
- (2) When thermo-on, the valve is controlled within the range of 70 to 480 pulses.
- (3) When the compressor maximum discharge temperature ≥ 98 °C, the degree of electronic control valve opening.
- (4) When the degree of heat at the outdoor heat exchanger (coil temperature – liquid temperature) is high, the degree of electronic control valve opening increases.
- (5) When the sub-cool of indoor unit (E2 temperature – E1 temperature) is low, the degree of electronic expansion valve opening reduces. However, (4) above takes precedence.
- (6) When the degree of overcooling at the indoor unit outlet (E2 temperature – E1 temperature) is high, the degree of electronic expansion valve opening is increased.
- (7) When the indoor heat exchanger temperature ≤ 30 °C, the electronic control valve returns to its initial pulse control.

17. Discharge Temperature Control (Only for U, D Type)

- If the range shown below is continuously detected for 6 minutes, the unit will thermo-off operation is initiated.

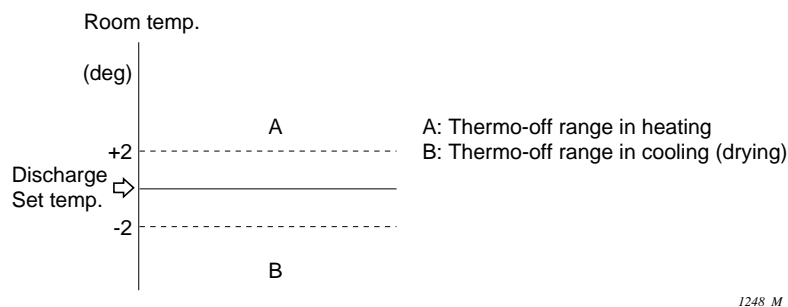

- *1. The discharge temperature was factory set as follows: 15 °C for cooling; 40 °C for heating
This can be changed using the simple setting mode on the remote controller.
2. For U and D type, thermo-off operation is initiated if one of the thermo-off conditions for normal room temperature control and the discharge temperature control is met.

2

18. Automatic Restart Function after Power Failure

Even when power failure occurs, preset programmed operation can be reactivated once power is resumes within 100 hrs.

19. Filter Sign

Filter sign informs you when maintenance is necessary.

- 2,500 hrs : X, S, T, SL, type
- 150 hrs : AS, K, F, FM type

Contents

3. Service Procedures

1. Troubleshooting	III - 2
1-1. Check before and after troubleshooting	III - 3
1-2. General troubleshooting flow chart: diagnosis and remedy	III - 6
1-3. Explanation of alarm messages	III - 8
1-4. Alarm messages on the outdoor PCB	III - 10
1-5. Symptoms and parts to inspect	III - 11
1-6. Procedures when a specific component does not work at all	III - 21
1-7. Service functions of remote controller	III - 23
(A) Set service check switches	III - 23
(B) Use the test run procedure	III - 24
(C) Check the sensor temperature readings	III - 25
(D) Find out about past service problems	III - 26
(E) Check the remote controller itself for correct operation	III - 28
(F) Execute the auto. address operation	III - 29
(G) Confirm and change the indoor unit address	III - 30
(H) Change the shift temperature in heating mode	III - 32
(I) Set the indoor unit address	III - 33
(J) Change the period of the filter timer	III - 36
2. Sensor and Solenoid Layout Diagram	III - 37
2-1. Outdoor unit	III - 37
2-2. Indoor unit	III - 39
3. Thermistor Characteristic Curve	III - 46
4. Test Run	III - 47
4-1. PCB setting & test run	III - 47
4-2. Main Alarm Messages which Indicate Mis-Wiring & Mis-Setting	III - 49
4-3. Main Alarm Messages Indicating Unit Malfunction	III - 49
5. PCBs illustrations	III - 50
Note when replacing the indoor unit PCB	III - 56
6. Checking of Density Limit	III - 53
7. Cautions for New Refrigerant R407C	III - 54
8. Compressor Failure	III - 56
8-1. Trouble shooting and method for checking the compressor	III - 56
8-2. Judgment of 2 compressors replacement	III - 56
9. Operation Procedure for Replacing the Compressor	III - 57
10. Malfunction due to Noise	III - 59
11. Checking procedure for PCB (Printed Circuit Board)	III - 59
12. Check Pins	III - 60
12-1. Indoor PCB (Printed Circuit Board)	III - 60
12-2. Outdoor PCB (Printed Circuit Board)	III - 60
13. Double Speed of Time for the Timer	III - 60

1. Troubleshooting

This section explains:

- What the LED codes mean
- What the remote controller display (screen) messages mean
- How to use the flow charts to find and solve problems
- How to use the self-diagnostic tests to find parts which don't work right

This unit is made to be trouble free, and not need much service. However, with time, moving parts wear out, electronic components break down, and sometimes misuse damages the unit.

The purpose of this section is to help you when the unit does not work properly.

Sometimes your experience will tell you right away where to look for a problem, and when you find it you will know how to fix it at once.

Often, however, all you have is a *symptom* like "poor cooling" or "outside fan doesn't come on." Now you must find out the cause of the problem, and then how to fix it. This section provides several ways to help you go from the symptom to the cause and then the solution.

The first chart, **General Troubleshooting Flow Chart** is divided into two sections: Poor heating and Poor Cooling.

Under each heading you will find the main things that can go wrong and cause either of these problems. Sometimes you can start with this chart and find the problem right away, but often you will come here for more suggestions after you have looked at the error code on the remote controller display. This chart gives you the "big picture" of problems and solutions.

The other main tool we explain here is the use of the **Alarm Messages**. When a certain part fails or a safety device has shut the unit down, any alpha-numeric codes appear on the display to guide you to the problem.

By understanding the code you can often go right to the problem area and then, with this manual and your knowledge of air conditioning, find the solution.

1. Troubleshooting

1-1. Check before and after troubleshooting

Many problems may happen because of wiring or power supply problems, so you should check these areas first. Problems here can cause false results in some of the following tests, and so should be corrected first.



WARNING

- **Since the check of interior of outdoor unit is very hazardous, always cut off its power supply at first. Begin the inspection more than 3 minutes after cutting off the power supply, and after ensuring that the unit has halted completely and that the LED of outdoor unit's P.C.B. Ass'y has turned OFF.**
 - **This is because a condenser of massive capacity is used inside the outdoor unit; and a charging load remains inside it even after the power has been cut off, and it takes about 3 minutes for it to get discharged.**
 - **While in usual state, do not disconnect the white connector of outdoor controller which is marked "CN1"; because it may cause malfunctioning.**
- (1) Check power supply wiring
 - Check that power supply wires are correctly connected to terminal plate in the outdoor unit.
 - Check the power supply wires are correctly connected between the terminal plate in the indoor unit and terminal plate in the outdoor unit.
 - (2) Check inter-unit wiring
 - Check that inter-unit control wiring (DC low voltage) is correctly connected between the indoor unit and outdoor unit.
 - (3) Check power supply
 - Check that voltage is within the specified range ($\pm 10\%$ of the rating).
 - Check that power is being supplied.



WARNING

If the following troubleshooting must be done with power being supplied, be careful not to touch any uninsulated live part that can cause ELECTRIC SHOCK.

- (4) Check the lead wires and connectors in indoor and outdoor units.
 - Check that the sheath of lead wires is not damaged.
 - Check that the lead wires are firmly connected at the terminal plate.
 - Check that the wiring is correct.

1. Troubleshooting

Wiring system diagram

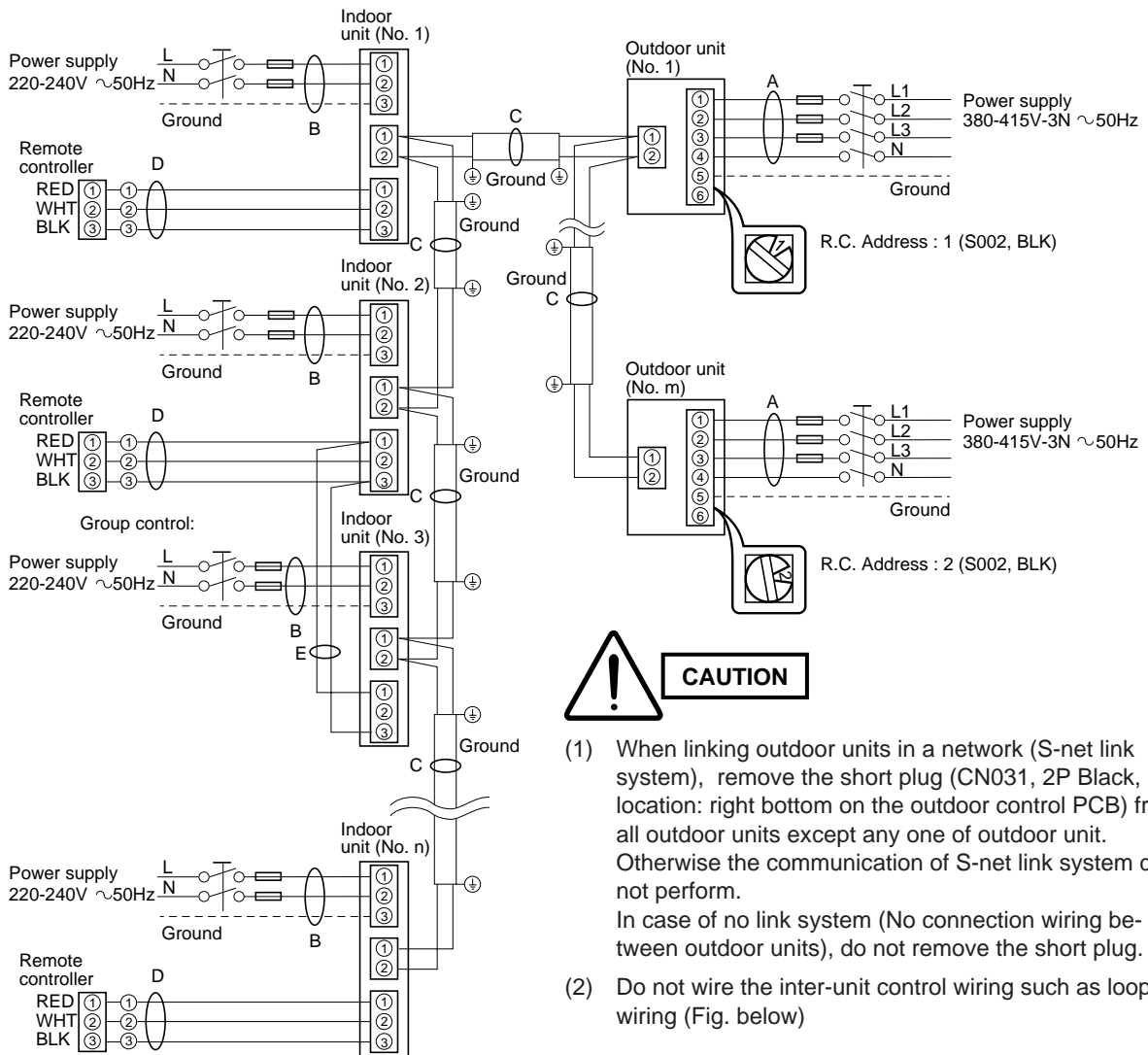

0796_M_1

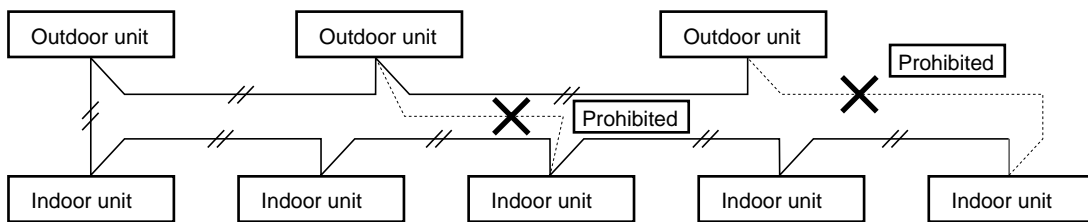

0192_M_1

3

1. Troubleshooting



- (3) Don't install the inter-unit control wiring such as star branch wiring. Star branch wiring causes mis-address setting.

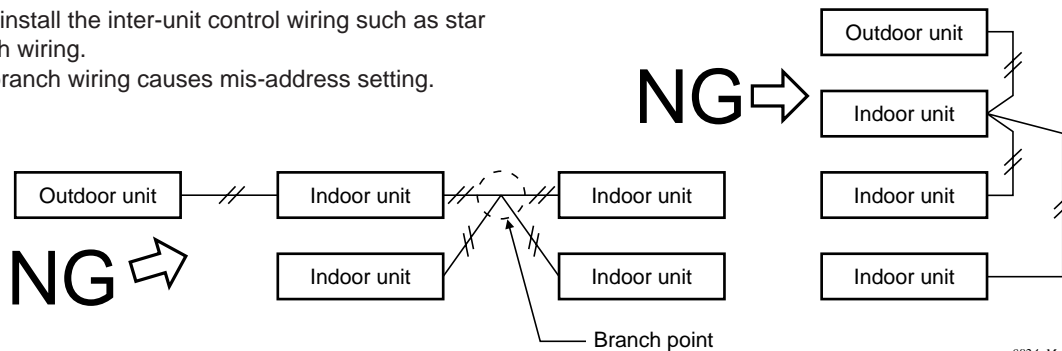

0824_M_1

- (4) If branching the inter-unit control wiring, the number of branch points should be 10 or less. (Branches less than 1 m are not included in the total branch number.)

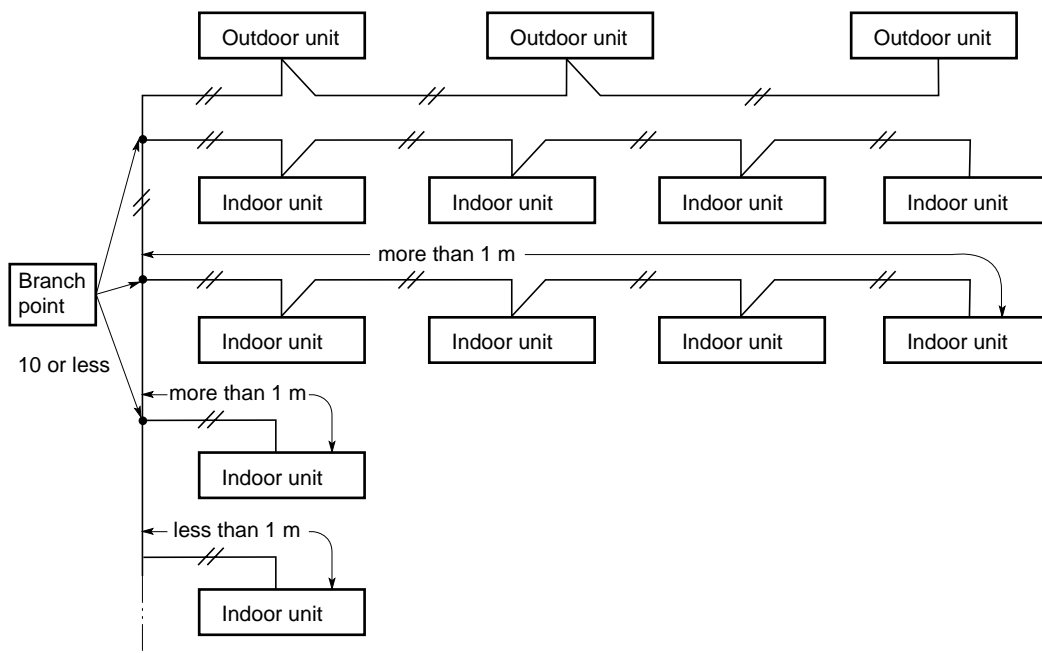

0193_M_1

- (5) Use shielded wires for inter-unit control wiring (c) and ground the shielded on both sides, otherwise misoperation from noise may occur. All wiring except inter-unit control wiring (c) has polarity.

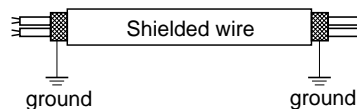

0797_M_1



1. Troubleshooting

1-2. General troubleshooting flow chart: diagnosis and remedy

When you have found a major problem, such as refrigerant not flowing in the system or reduced air circulation, come to this section and find the box listing the problem.

Connected to the box are the main causes of the problem and their remedies. To find out which malfunction is happening in your case, check the remote controller for an Alarm Message, and follow the steps in section 1-4).

(A) Cooling

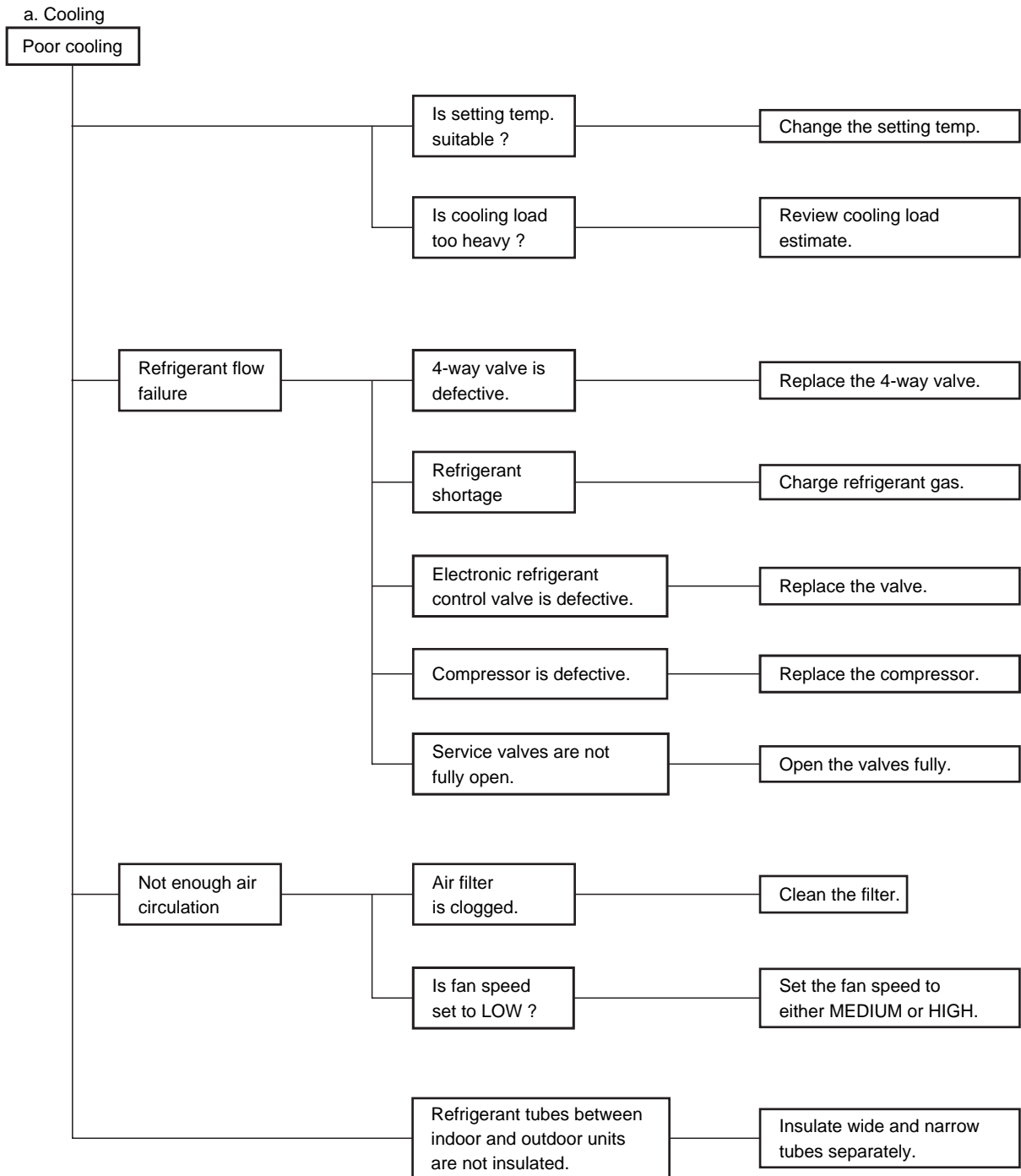

0458_M_I

1. Troubleshooting

(B) Heating

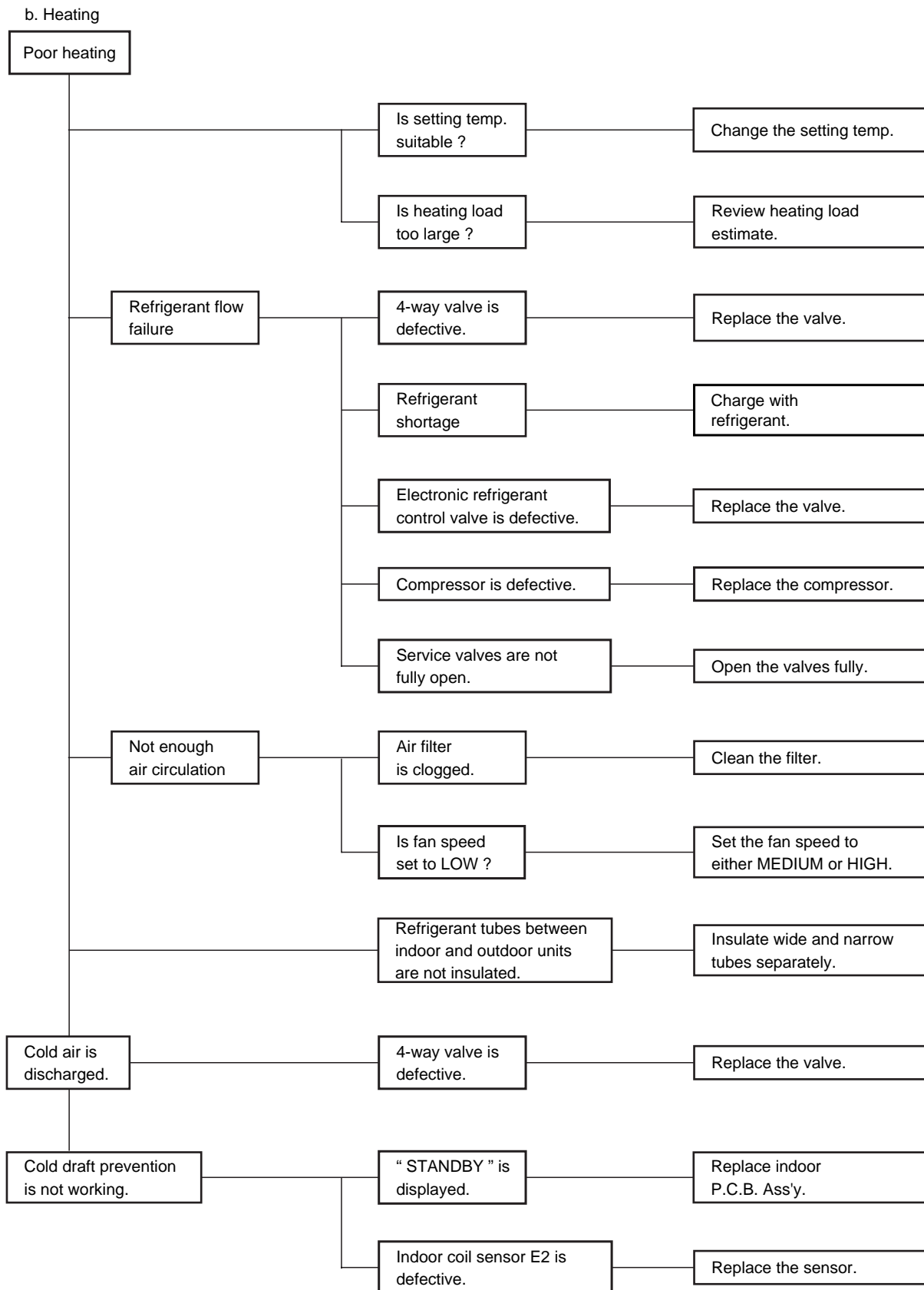

0459_M_1

1. Troubleshooting

1-3. Explanation of Alarm Messages

Possible Cause of Malfunction		Alarm message
<ul style="list-style-type: none"> • Serial communication errors • Mis-setting 	Remote controller is detecting error signal from indoor unit.	Error in receiving serial communications signal. E1
		Error in transmitting serial communications signal. E2
	Indoor unit is detecting error signal from the remote controller. (No serial communications signal)	E3
	Indoor unit is detecting error signal from outdoor unit.	Error in receiving serial communications signal. E4
		Error in transmitting serial communications signal. E5
	Outdoor unit is detecting error signal from indoor unit.	Error in receiving serial communications signal. E6
	Indoor unit is not working correctly.	<ul style="list-style-type: none"> • Indoor unit is damaged. • Power is not supplied.
	Improper setting of indoor unit or remote controller.	Indoor unit address setting is duplicated. E8
		Remote controller address (RCU.ADR) switch is duplicated. E9
		Do not press Auto. address button S001: (A. ADD) of another R.C. line during Auto. address operation. E12
	Error in Auto. address setting. (No. or capacity of judged indoor unit is small.)	E15
Error in Auto. address setting. (No. or capacity of judged indoor unit is large.)	E16	
Indoor unit is detecting error signal from another indoor unit.	E18	
Activation of protective device	Protective device in indoor unit is activated.	• Thermal protector in indoor fan motor is activated. P1
	Protective device in outdoor unit is activated.	• Thermal protector in outdoor fan motor is activated. • PC or AC Compressor thermal protector is activated. • Power supply voltage is unusual. (The voltage is more than 270 V or less than 160 V between L and N phase.) P2
		Incorrect discharge gas temp. of PC comp. P3
		High-pressure switch is activated. P4
		Incorrect power supply voltage . Negative phase, defective phase or voltage drop. P5
		Incorrect discharge gas temp. of AC comp. P17
	Protective device in indoor unit is activated.	Improper wiring connections of ceiling panel. P9
		Float switch is activated. P10

NOTE

- RCU : Remote Control Unit (remote controller)
- R.C. : Refrigerant Circuit
- PC : Power Control
- AC : Standard
- comp. : Compressor
- temp. : Temperature
- PCB : Printed Circuit Board

1. Troubleshooting

Possible Cause of Malfunction			Alarm message
Thermistor failure	Indoor thermistor is either open or damaged.	Indoor coil temp. (E1=TH1) cannot be detected.	F1
		Indoor coil temp. (E2 = TH2) cannot be detected.	F2
		Indoor coil temp. (E3 = TH3) cannot be detected.	F3
		Indoor room (air-intake) temp. can not be detected.	F10
	Outdoor thermistor is either open or damaged.	Discharge air temp. can not be detected.	F11
		Discharge gas temp. A (PC comp. =TH01) cannot be detected.	F4
		Discharge gas temp. B (AC comp. =TH02) cannot be detected.	F5
		Outdoor coil gas temp. (TH04) cannot be detected.	F6
		Outdoor coil liquid temp. (TH03) cannot be detected.	F7
	Outdoor air suction temp. (TH05)	F8	
EEPROM (ICB of PCB) failure			F29
Fault with comp. and its circuit	Protective device for PC comp. is activated.	PC comp. motor is overloaded.	H1
		PC comp. motor is locked.	H2
		Current of PC comp. cannot be detected when it is turned on.	H3
		Current of PC comp. is detected when it is not operated.	F27
		PC comp. contactor (Mg SW) is chattering.	H9
	Protective device for AC comp. is activated.	AC comp. motor is overloaded.	H11
		AC comp. motor is locked.	H12
		Current of AC comp. cannot be detected when it is turned on.	H13
		Current of AC comp. is detected when it is not operated.	F28
	AC comp. contactor (Mg SW) is chattering.	H19	

Possible cause of Malfunction	Alarm message
Main indoor unit address is not set.	L1
Model setting of indoor unit is not matching the outdoor unit.	L2
When using group control, main indoor unit address setting is duplicated. (Judging by indoor unit.)	L3
Outdoor unit address (R.C. No.) is duplicated.	L4
Priority setting of indoor unit is duplicated.	L5
—	L6
Improper wiring between indoor units. (There is group connection wiring in case of individual control.)	L7
Indoor unit address (or group address) is not set.	L8
Capacity code of indoor unit is not set.	L9

Possible Cause of Malfunction (The following messages are displayed only for the system controller.)			Alarm message
• Serial communication errors • Mis-setting	System controller is transmitting incorrect signal.	• Indoor or outdoor unit is not working correctly. • Control lines between indoor unit, outdoor unit, and system controller are not wired correctly.	C05
	System controller is detecting incorrect signal.	• Same as for C05, above. • Connector CN1 is not connected correctly.	C06
Activation of protective device	Protective device of the sub-indoor unit is activated in group control.	When using wireless remote controller or system controller, connect wired remote controller with the indoor unit temporarily to check the alarm message in detail.	P30

NOTE

- PC : Power Control
- AC : Standard
- comp. : Compressor
- temp. : Temperature

1. Troubleshooting

1-4. Alarm Messages on the Outdoor PCB

(In ordinary use, the outdoor alarm LED (yellow) is off and the LED (red), which indicates the number of connected indoor units, is turned on.)

Alarm messages indicated by the LED (red) on the outdoor PCB.

- When the outdoor alarm LED (yellow) is OFF, the LED (red) lamps blink → Thermostat OFF run, with no alarm display on the remote controller.
- When the outdoor alarm LED (yellow) is ON, LED (red) lamps light up → An alarm message is also displayed on the remote controller.

☼ : light - up / blink

Remote controller display	LED (red)								Possible cause of fault	
	8	7	6	5	4	3	2	1		
E4	Connected indoor units' No. of LED (red) lamps blink or all lamps turned off								When turning on the power supply, No. of indoor units connected is not correspond with set No. of S004 (except R.C. No. setting is 0).	
E6		☼				☼	☼		Serial signal receiving	Serial signal receiving fault Indoor/outdoor unit combination fault (incorrect indoor unit count : S004 setting)
E7		☼				☼	☼	☼	Serial signal sending fault	Serial signal sending fault
E15		☼			☼	☼	☼	☼	The number of connected indoor units are less than the set number in the outdoor PCB.	During Auto. address setting, alarm LED (yellow) lamp lights up. The LED (red) lamps light up or blink when CN25 (2 pin plug, white) is shortened.
E16		☼		☼					The number of connected indoor units are more than the set number in the outdoor PCB.	
P2	☼	☼	☼					☼	Protective device activated	Fan motor protection thermostat PC comp. protection thermostat AC comp. thermostat Defective phase
P3	☼	☼	☼					☼	Incorrect discharge temp.	PC comp.
P4	☼	☼	☼			☼			High-pressure switch	PC comp. or AC comp.
P5	☼	☼	☼			☼		☼	Protective device activated	Negative phase protector or defective phase protector, or Voltage drop protector
F4		☼	☼			☼			Sensor fault	Discharge temp. A (PC comp.)
F5		☼	☼			☼		☼		Discharge temp. B (AC comp.)
F6		☼	☼			☼	☼			Outdoor coil gas temp. (C2)
F7		☼	☼			☼	☼	☼		Outdoor coil liquid temp. (C1)
F8		☼	☼		☼					Outdoor air suction temp.
P17	☼	☼	☼	☼				☼	Incorrect discharge gas temp. of AC comp.	
H1	☼							☼	PC comp.	Error in Current value (overload)
H2	☼							☼	CT detection current	Error in Current value (lock)
H11	☼				☼		☼	☼	AC comp.	Error in Current value (overload)
H12	☼				☼	☼			CT detection current	Error in Current value (lock)
H9	☼				☼			☼	Comp. contactor protection	PC (AC) comp. contactor is chattering.
H19	☼			☼				☼	Comp. contactor protection	AC comp. contactor is chattering.
L4	☼	☼						☼	Outdoor unit address (R.C. No.) is duplicated.	

NOTE

- PC comp. : Power Control Compressor
- AC comp. : Standard Compressor
- temp. : Temperature

1. Troubleshooting

1-5. Symptoms and parts to inspect

(1) Symptom: LCD on the remote controller does not display and remote controller does not operate.

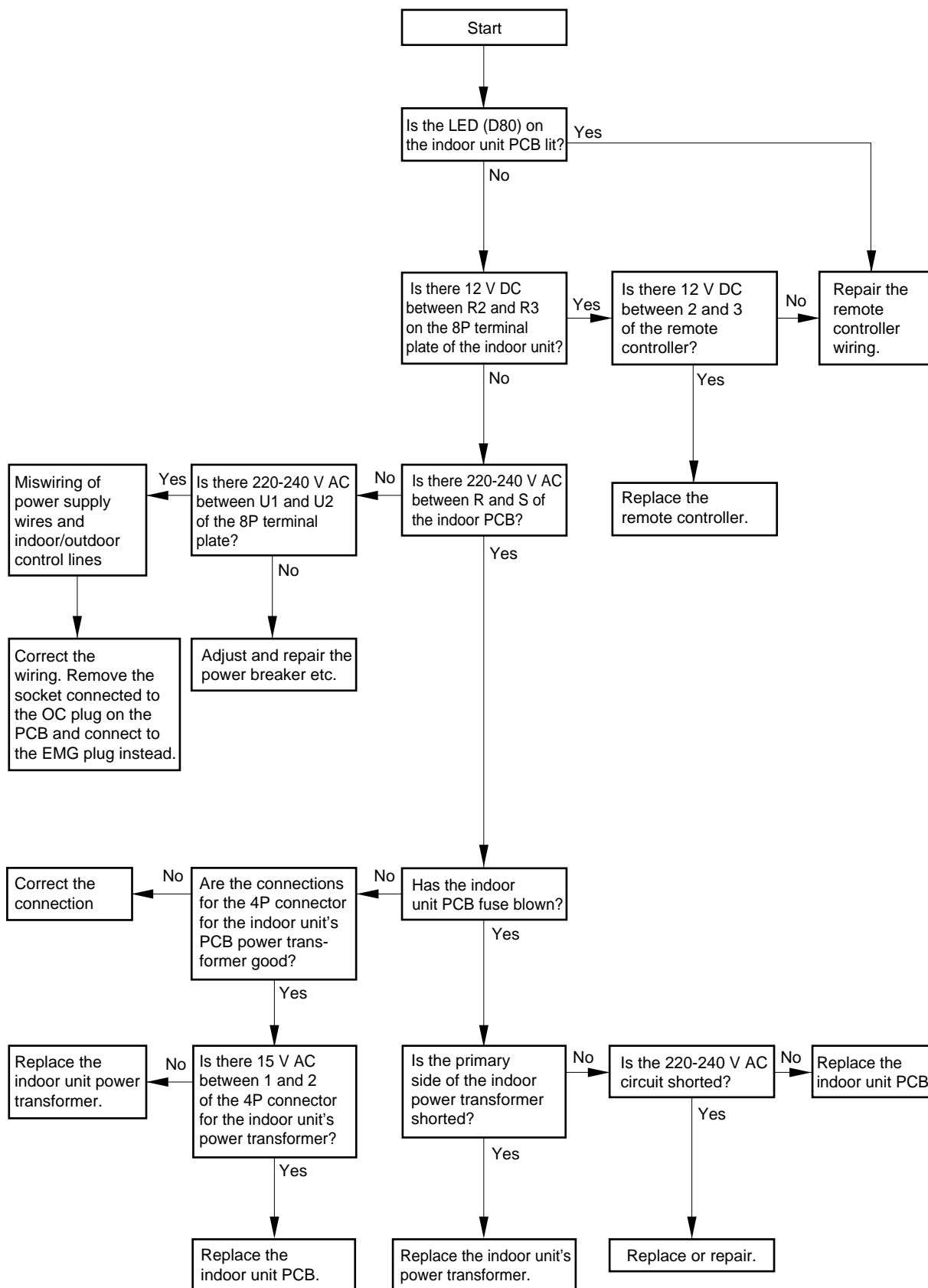

1. Troubleshooting

(2) Symptom: LCD on the remote controller displays "CHECK E01". (Unusual communication between remote controller and indoor unit, or R.C. address, indoor unit address, or group address in indoor unit non-volatile memory are not set.

- ① For only 1 system (outdoor unit system address 0)
 - The first time you switch on the power for the outdoor units after installation, "SETTING" blinks on the remote controller and the system enters automatic address operation, but if the outdoor unit power is not on or the indoor / outdoor operation line is not connected, the automatic operation can not be executed, so the indoor unit non-volatile memory system address, indoor unit address, or group address remains unset (0099). If you press the remote controller ON / OFF operation button with the system in this state, "Fan speed" is displayed and an alarm is displayed.
- ② For multiple systems with the indoor/outdoor operation lines linked (outdoor unit system address other than 0)
 - After the indoor and outdoor unit power is switched on, if you do not carry out the automatic address setting operation with the remote controller or the outdoor unit, the same alarm is displayed.
- ③ After the automatic address setting has been completed

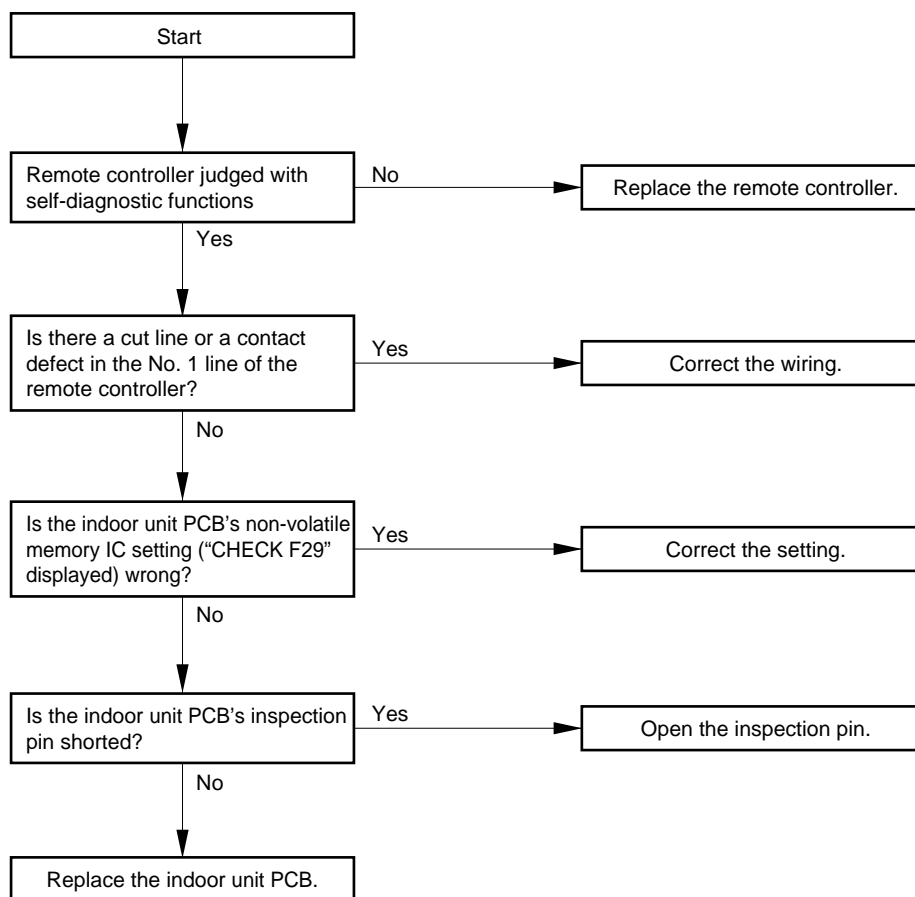

0333_M_I

3

1. Troubleshooting

- (3) Symptom: LCD on the remote controller displays "CHECK E02". (Unusual communication between remote controller and indoor unit)

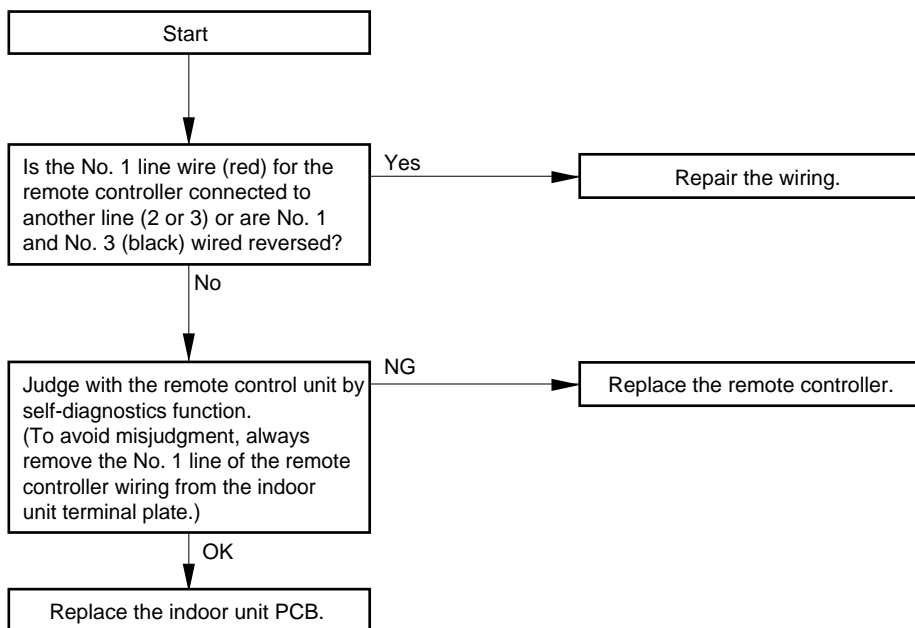

0334_M_I

1. Troubleshooting

(4) Symptom: LCD on the remote controller is displaying “CHECK E04”. (Unusual communication between the indoor and outdoor units or inappropriate combination of indoor and outdoor units)

- ① The outdoor unit cannot communicate with the indoor unit. Or the power supply to the outdoor unit is off.
- ② When the power is switched on for an indoor unit for which the outdoor unit and indoor unit addresses etc. have been set, the number of units connected to the indoor unit and the number of units set for the outdoor side do not match (other than when the outdoor system address is 0).

NOTE

When the outdoor system address is 0, if the indoor unit judges that the combination of indoor unit and outdoor unit is inappropriate, the system starts automatic address setting operations and the remote controller displays the “CHECK E15” or “CHECK E16” alarm.

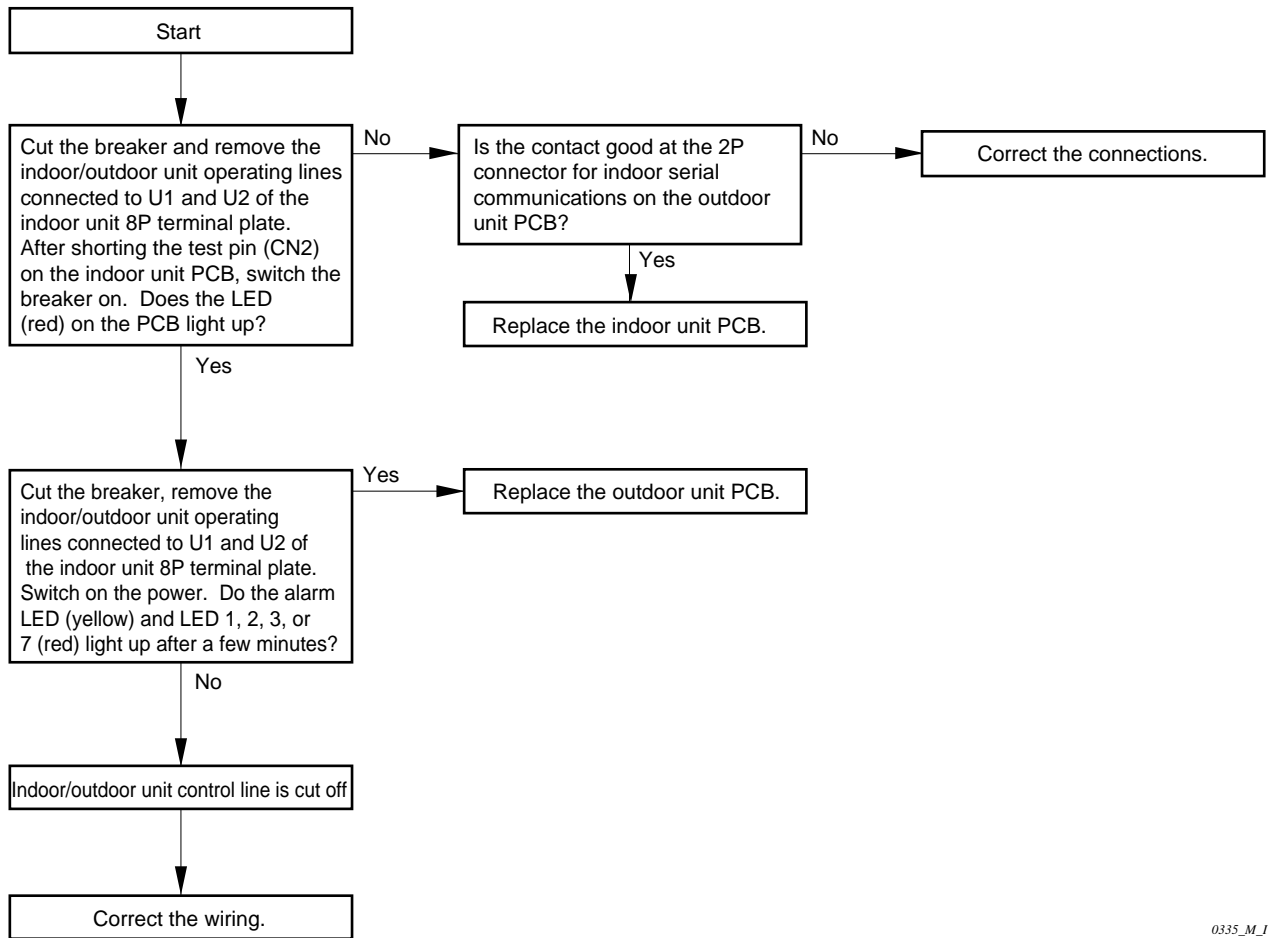

0335_M_I

(5) Symptom: LCD on the remote controller is displaying “CHECK E05”. (Unusual communication between the indoor and outdoor units)

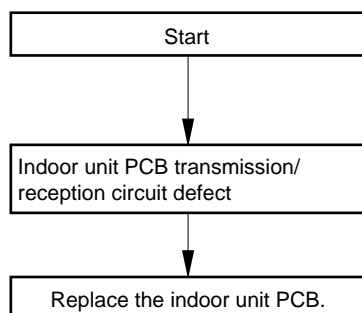

0336_M_I



1. Troubleshooting

(6) Symptom: LCD on the remote controller is displaying “CHECK E06”. (Unusual communication between the indoor and outdoor units)

- ① This message is displayed when the power was switched on for the indoor and outdoor units, the combination of indoor and outdoor units matches, but afterwards a problem occurred in the indoor unit disabling transmission to the outdoor unit.

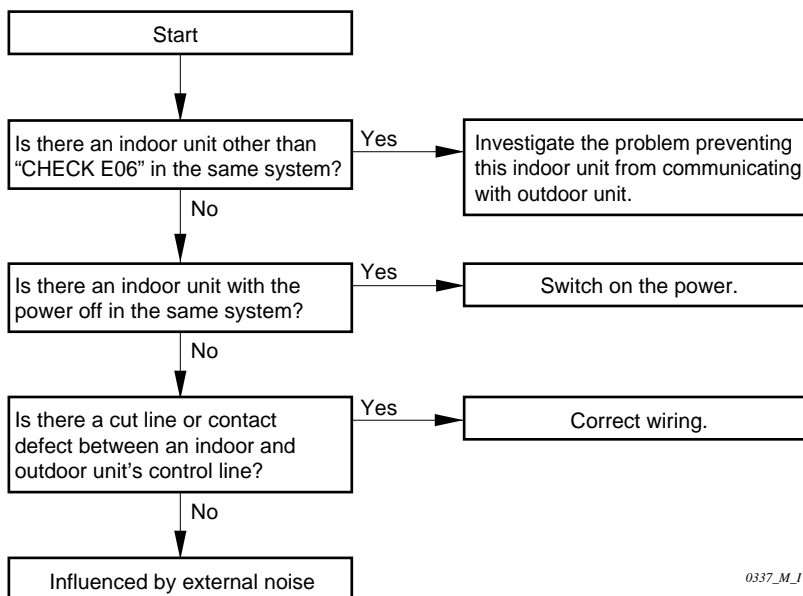

(7) Symptom: LCD on the remote controller is displaying “CHECK E08”. (Duplicate indoor unit address setting)

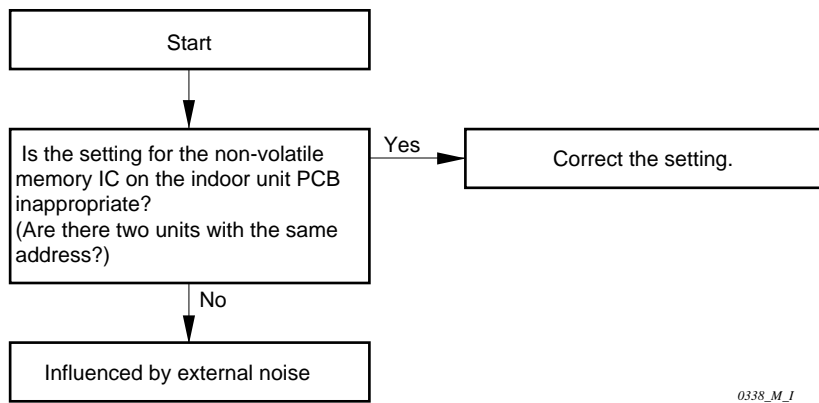

(8) Symptom: LCD on the remote controller is displaying “CHECK E09”. (Duplicate setting of RCU address switch of remote controllers)

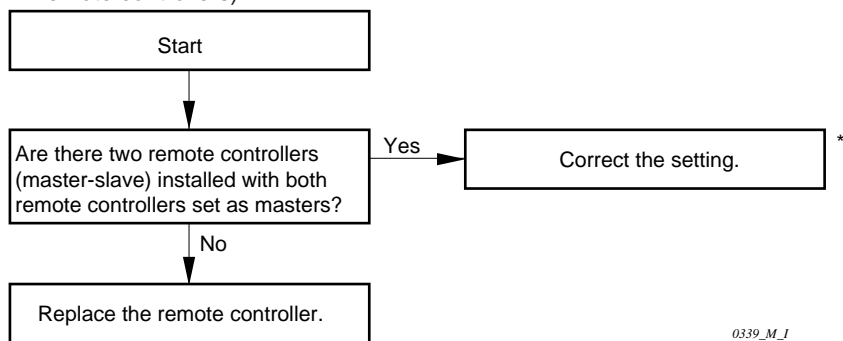

* See the section of ENGINEERING MANUAL and INSTALLATION INSTRUCTION concerning with controlling remote controller switches when there are two remote controllers.



1. Troubleshooting

(9) Symptom: LCD on the remote controller is displaying “CHECK E15” or “CHECK E16”. (Inappropriate indoor combination)

- ① When the outdoor unit judges a mismatch between the number of connected indoor units and the number of indoor units set at the outdoor unit (S004) after automatic address setting operation, the outdoor unit sends the indoor unit the alarm signal and displays “CHECK E15” or “CHECK E16” on the remote controller.
- ② When the power is switched on when the outdoor and indoor unit addresses have already been set, if the number of indoor units connected and the number set at the outdoor unit do not match, the outdoor unit starts automatic address operations again. As a result, if the outdoor unit judges that there is an inappropriate indoor/outdoor combination, it displays “CHECK E15” or “CHECK E16” on the remote controller. (But only if the outdoor system address is 0)

(10) Symptom: LCD on the remote controller displays “CHECK P01”. (Indoor fan protection thermostat)

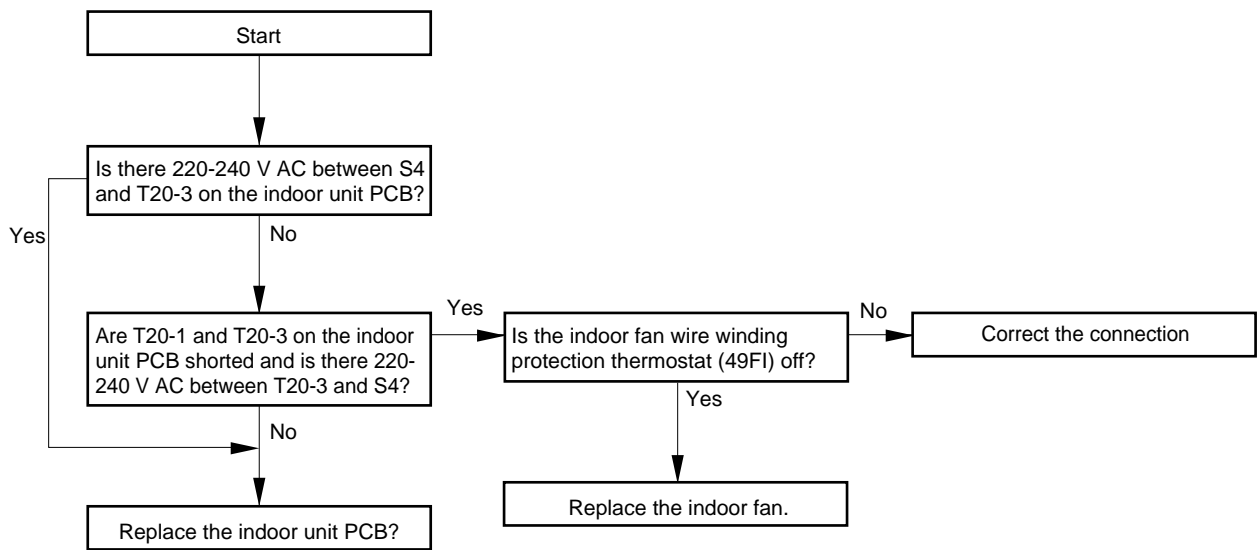

0340_M_I

(11) Symptom: The remote controller LCD displays “CHECK P10”. (Indoor floating switch operation)

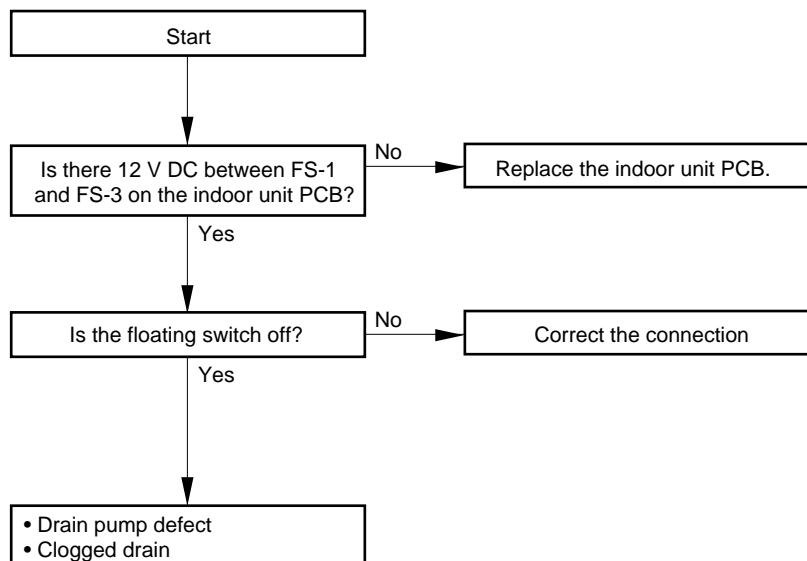

0341_M_I

3

1. Troubleshooting

(12) Symptom: LCD on the remote controller displays "CHECK P02". (Compressor / outdoor fan protection thermostat)

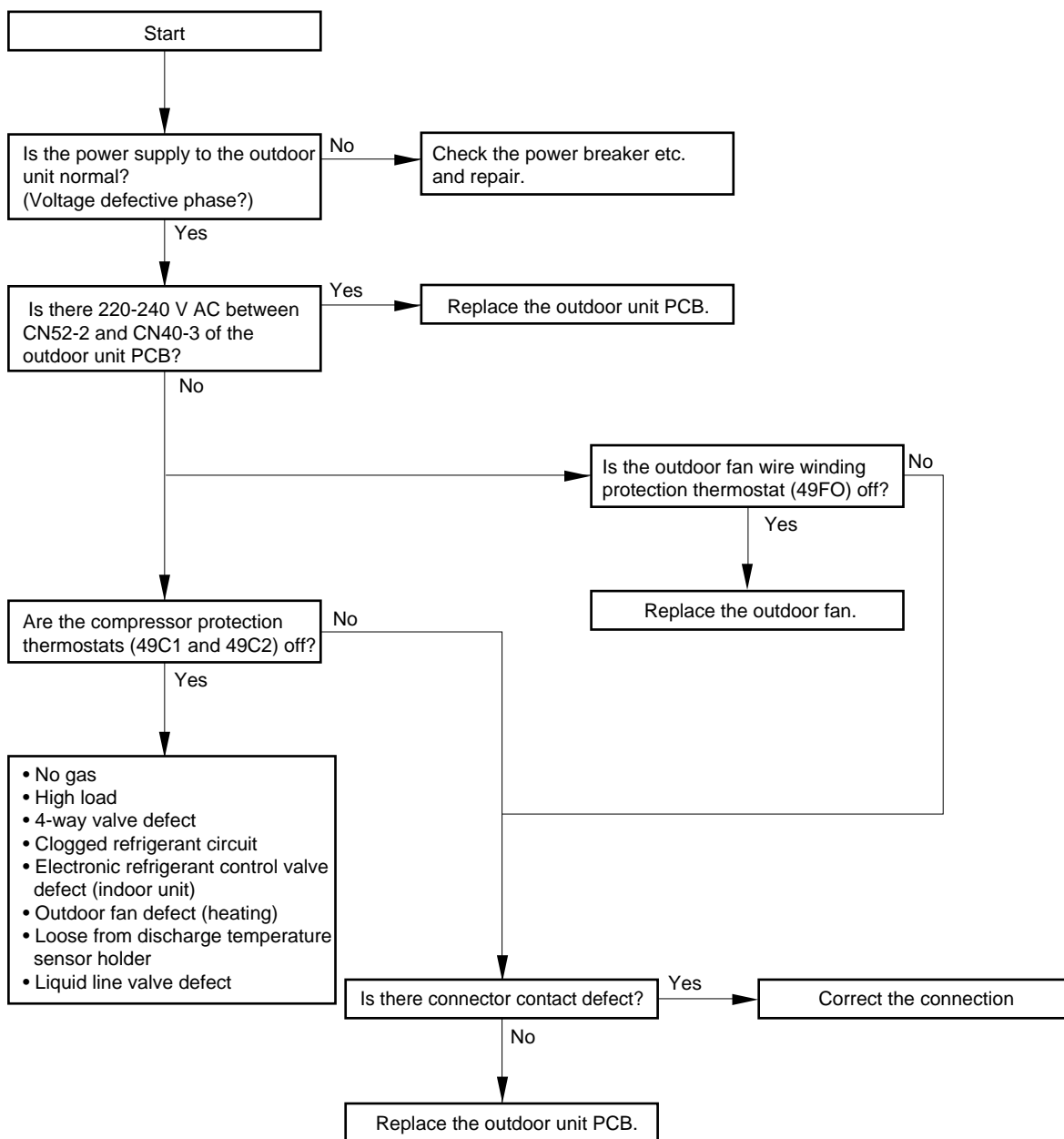

0342_M_1



1. Troubleshooting

- (13) Symptoms: LCD on the remote controller displays "CHECK P03".
 (Alarm for unusual PC comp, discharge temp.)
 The remote controller LCD displays "CHECK P17".
 (Alarm for unusual PC comp, discharge temp.)

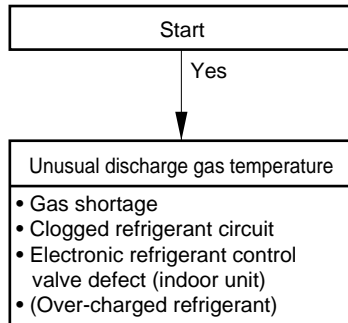

0343_M_I

- (14) Symptom: LCD on the remote controller displays "CHECK P04". (High-pressure switch operation)

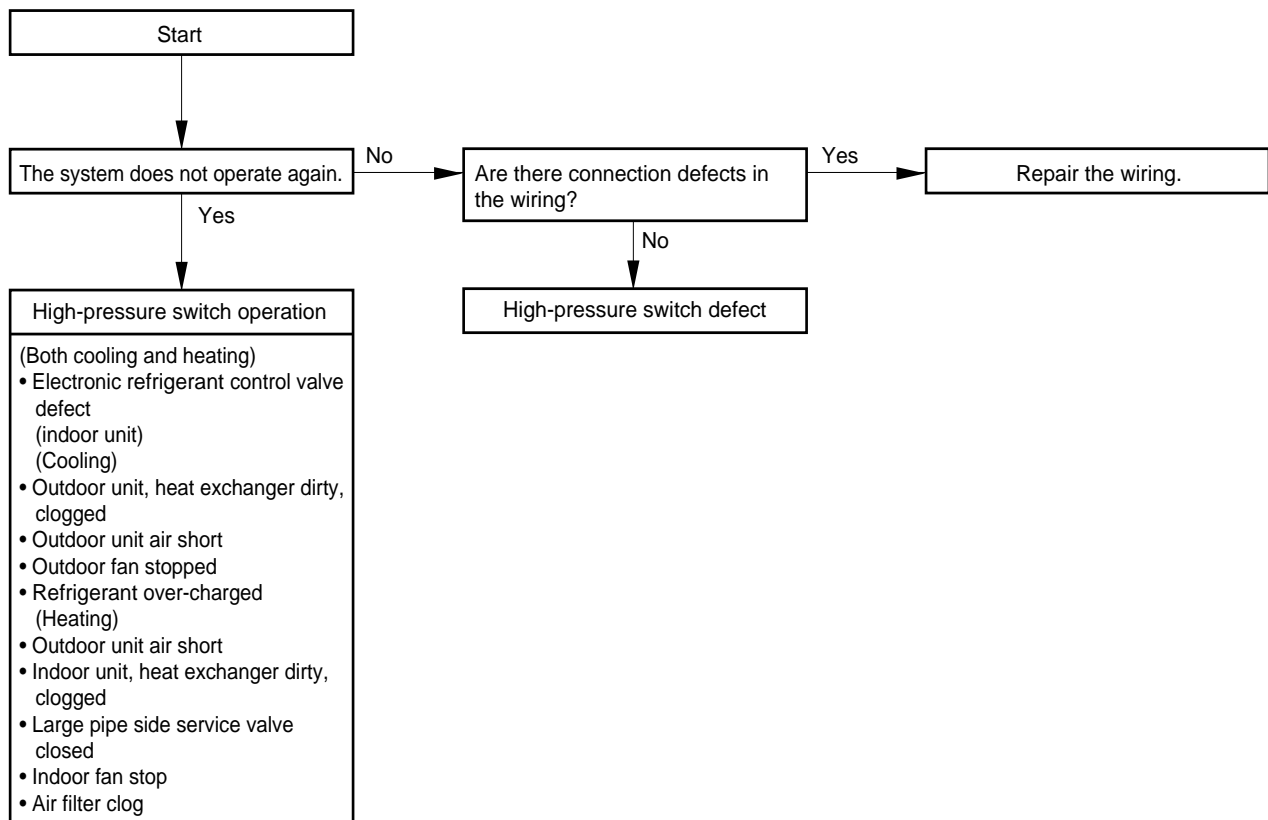

0344_M_I

3

1. Troubleshooting

(15) Symptom: LCD on the remote controller displays "CHECK P05". (Reversed phase detection)

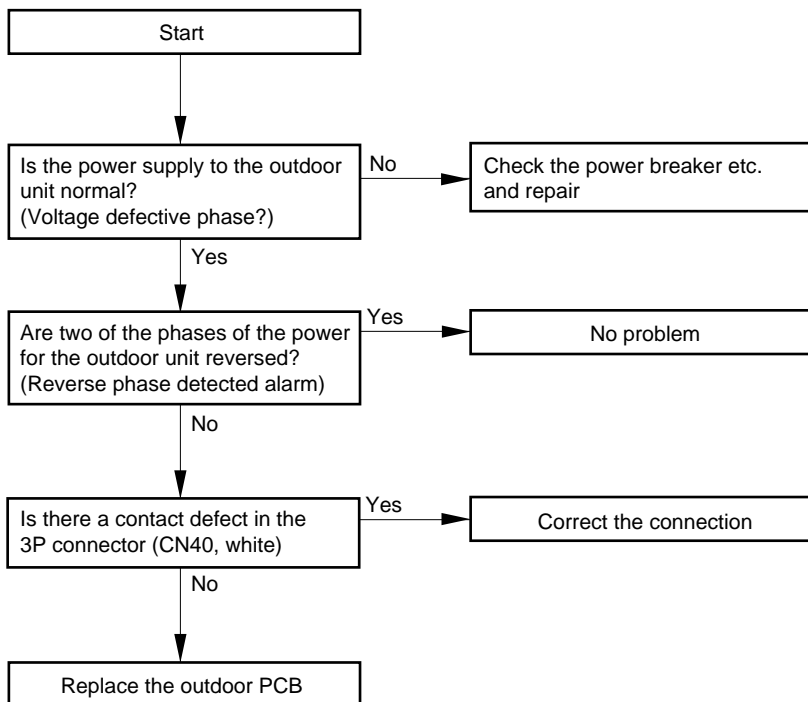

0345_M_I

(16) Symptom: LCD on the remote controller displays "CHECK H01, H02, H03". (PC compressor current detection)

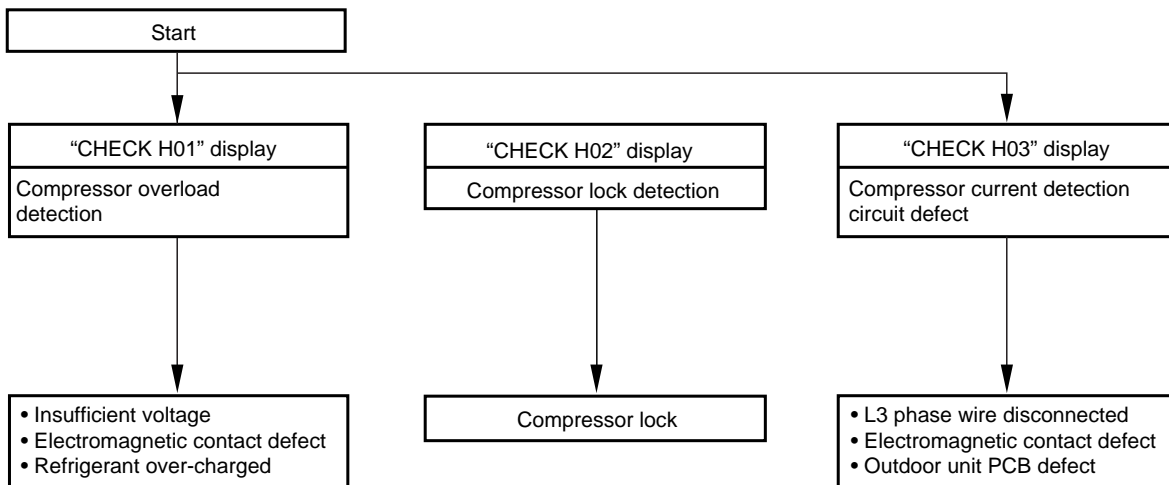

0346_M_I



1. Troubleshooting

(17) Symptom: LCD on the remote controller displays "CHECK H11, H12, H13". (AC compressor current detection)

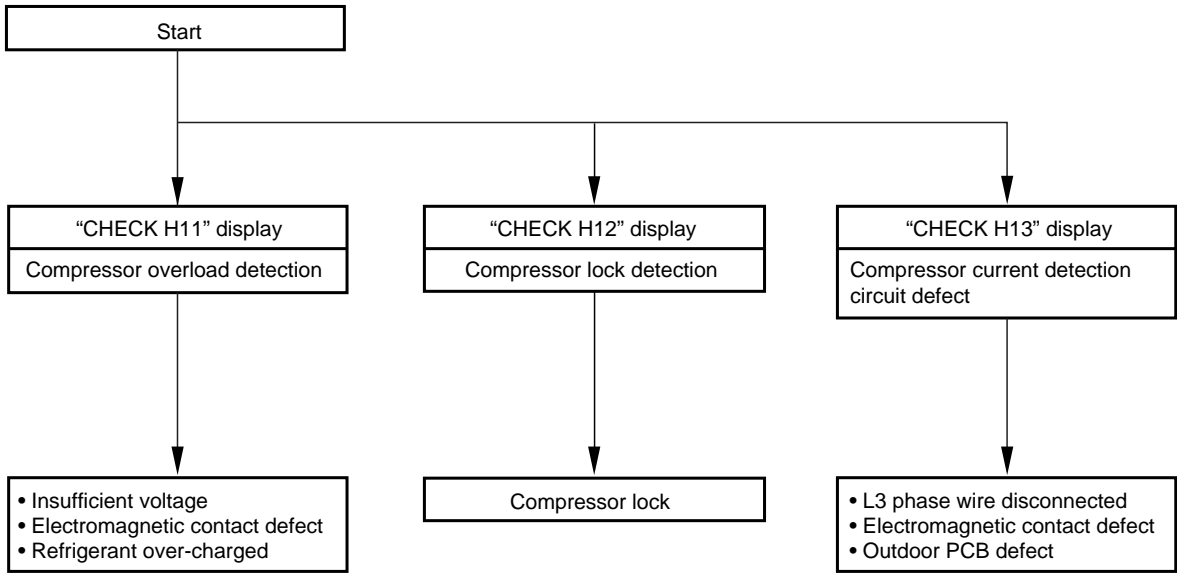

0347_M_I

1. Troubleshooting

1-6. Procedures when a specific component does not work at all

- (1) Check the indoor unit (When the alarm of transmission failure is not activated)
- In case that the unit is controlled by Flexible Combination, an electronic control valve failure has occurred or one of the units cannot be controlled due to electronic control valve circuit failure, and other units do not operate normally either. Due to this, try to detect the troubled unit and correct it.

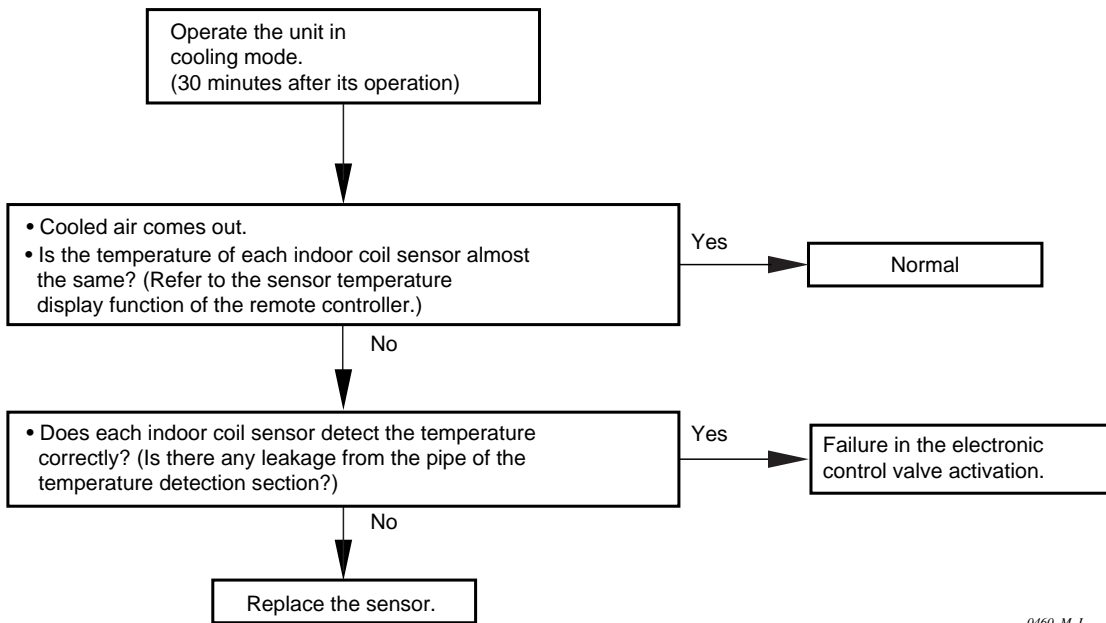

- (2) Compressor motor is not running at all.

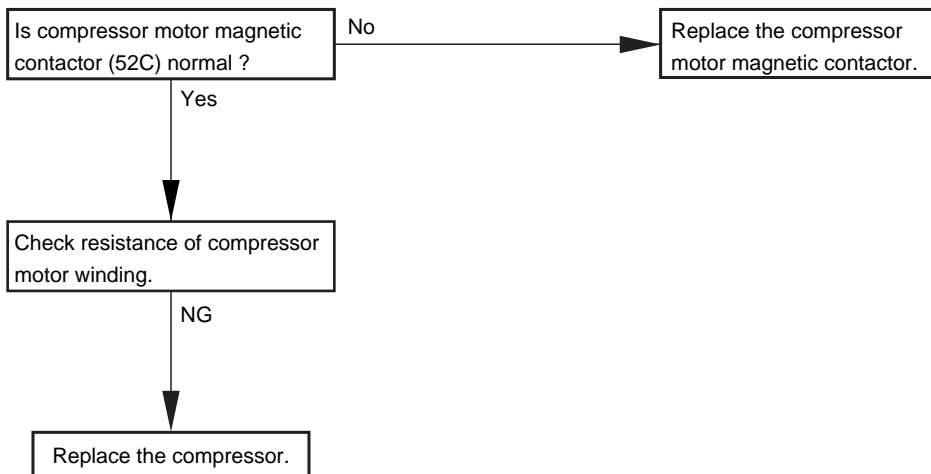

1. Troubleshooting

(3) Outdoor fan is not running at all.

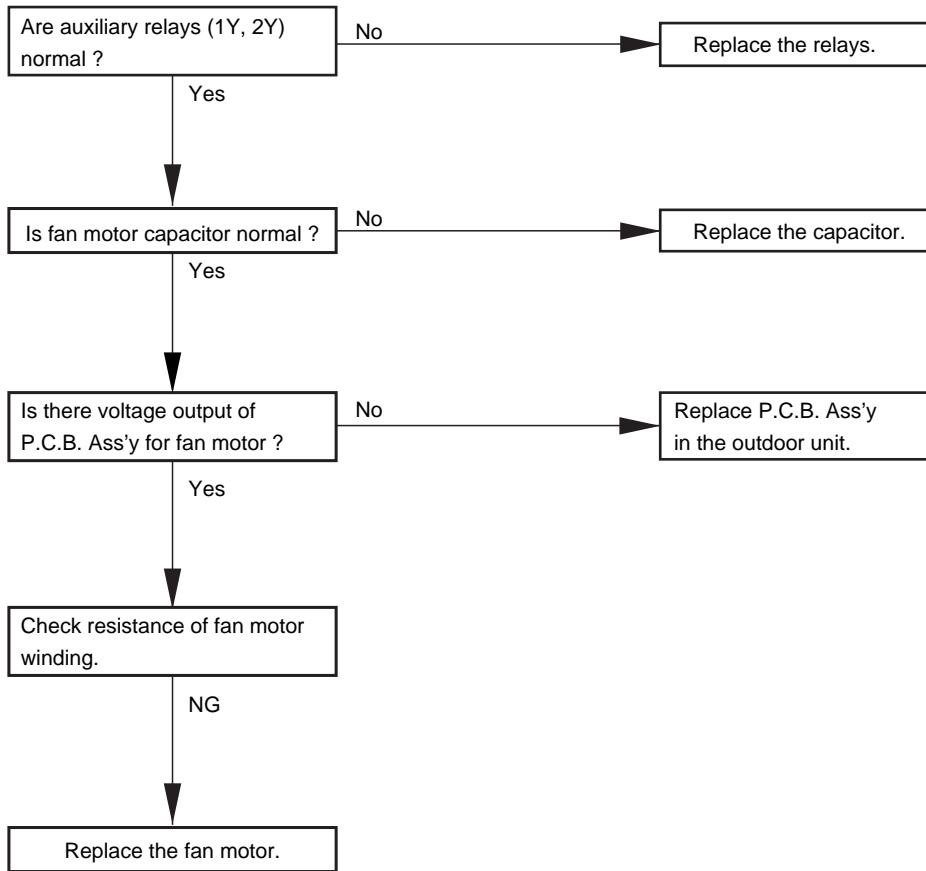

0462_M_1

3

1. Troubleshooting

1-7. Service functions of remote controller

From the remote controller you can control both the operation and settings of the unit as well as perform several useful service checks. This section explains how to use the remote controller on the following items from (A) to (J).

- (A) Set service check switches.
- (B) Use the test run procedure.
- (C) Check the sensor temperature readings.
- (D) Find out about past service problems.
- (E) Check the remote controller itself for correct operation.
- (F) Execute the auto. address operation.
- (G) Confirm and change the indoor unit address.
- (H) Change the shift temperature in heating mode
- (I) Set the indoor unit address.
- (J) Change the period of the filter timer

(A) Set service check switches

The service check switches are located on the back of the remote controller's P.C.B. Ass'y as follows :

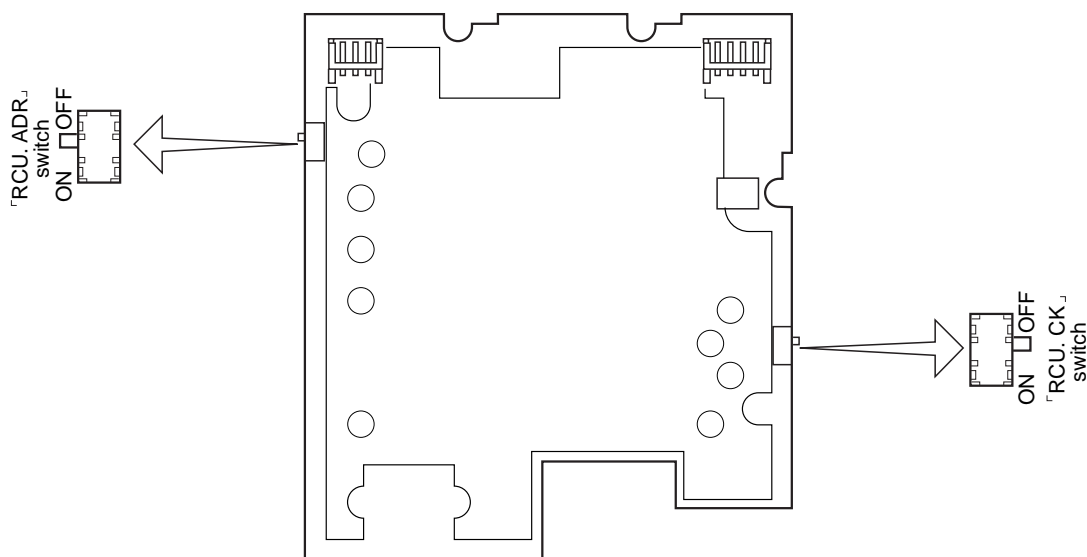

0354_M_I

The followings are the correct switch settings for ordinary use of the unit. Only change the settings temporarily for making service checks. When you have changed the settings, **be sure to return them to the standard settings** shown here.

- RCU.CK** switch - Refer to section (E) " **Checking the remote controller for correct operation**" (Remote Control Unit, Check)
- RCU.ADR** switch - Keep the switch **OFF** all the time except in case of sub remote controller (Remote Control Unit, Address)

1. Troubleshooting

(B) Use the test run procedure

- ❑ The purpose of the test run function is to let you control the operation of the unit directly without turning the unit on or off by thermostat. As indicated in the following procedure, be sure to stop test run operation when you finish the procedure, or the air conditioner may be damaged because it won't turn on and off normally.
- ❑ To protect the air conditioner from overloading, the outdoor unit will not start running for 3 minutes after power is applied or the unit is turned OFF.

- a Press the **TEST / CHK** button at the bottom right on the remote controller.
- b Press the ON / OFF operation button to start the test run.
- c Press the **MODE** button to select either COOLING or HEATING mode.
- d When the test run starts, "TEST" shows on the remote controller's display.
- e During the test run, the air conditioner runs continuously and the thermostat does not control the system.
- f After the test run, be sure to press the **TEST / CHK** button once again to finish this mode and be sure "TEST" is not shown on the display.

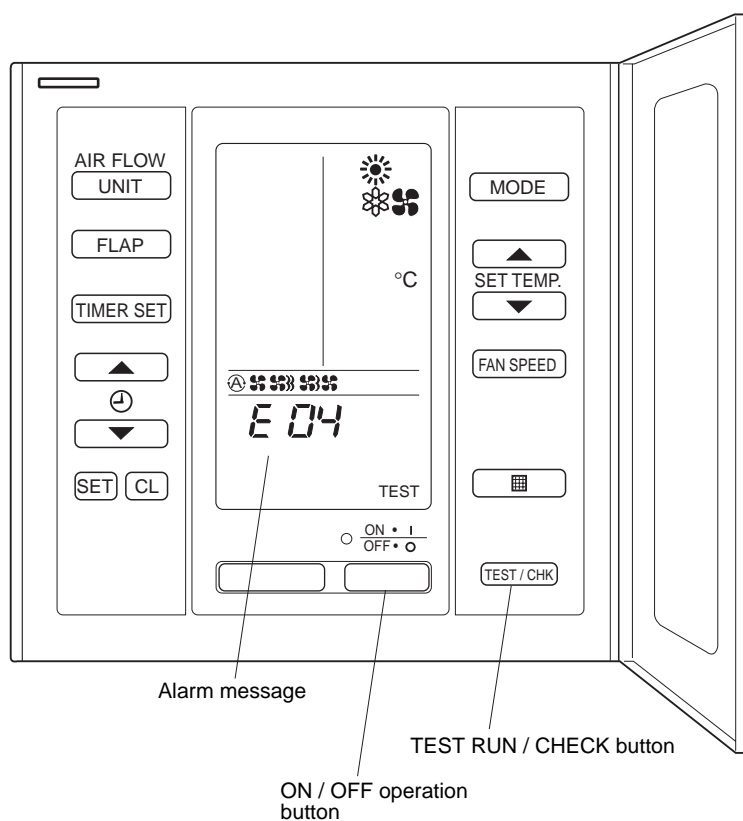

1152_THS_1



The TEST RUN button is used only for servicing the air conditioner. Do not press this button in normal operation, or the system may be damaged.

1. Troubleshooting

(C) Check the sensor temperature readings

The air conditioner has thermo sensors which are used to control the unit.

- ❑ Each sensor has an address which is made up of the indoor unit address, and the sensor address. The indoor unit address is used only when several units are hooked up to one remote controller (group control). If there is only one unit, made up of one indoor and one outdoor unit, then only the sensor address should be put in, as shown in the procedure below.

Follow this procedure to display the temperature of each sensor:

- Ⓐ On the remote controller, press both **TEST / CHK** and **CL** buttons at the same time for more than 4 seconds.

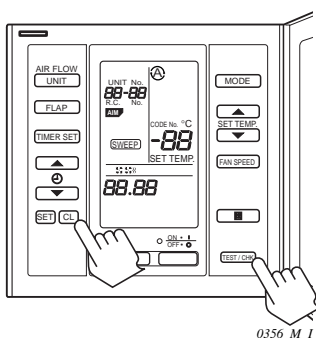

- Ⓑ The UNIT No., the address and temperature of the sensors instead of its usual information will flash on the display.
 - ❑ Following example shows the UNIT No. (Indoor unit address) is fixed at **01-01**.
 - ❑ In case of group control, select the UNIT NO. (Indoor unit address) which you want to check with **UNIT** button.
 - ❑ Each time you press the **▲**, **▼** (SET TEMP.) button you can select a different sensor, and the display shows the sensor address and temperature as shown below.

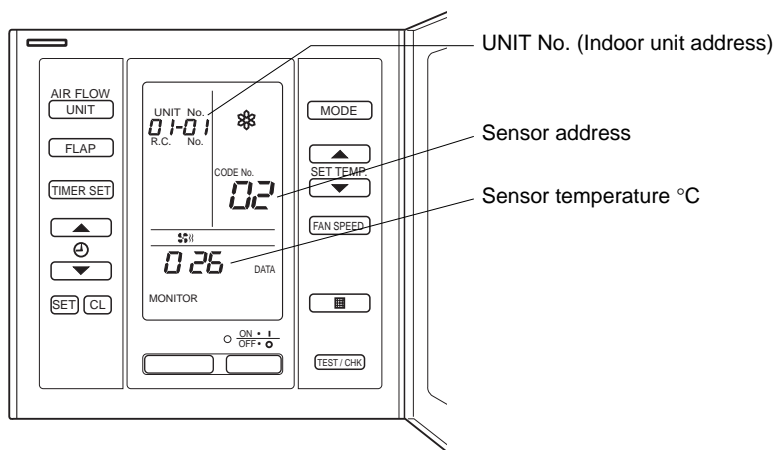

NOTE

Do not press **TIMER SET** button during the procedure.



1. Troubleshooting

Refer to the table below for the relationship between the sensor address and the location of the sensor.

Relationship between the sensor address and the location of sensor

Sensor Address (CODE No.)		Location of Sensor (Themistor)	
Indoor Unit	01	—	
	02	TH1	Indoor air suction Temp.
	03	TH2	Indoor coil Temp. (E1)
	04	TH3	Indoor coil Temp. (E2)
	05	TH4	Indoor coil Temp. (E3)
Outdoor Unit	06	—	
	07	—	
	08	Indoor Electronic Control Valve Open (pulse)	
	09	—	
	0A	TH01	Discharge gas Temp. A (PC Compressor)
	0B	TH02	Discharge gas Temp. B (AC Compressor)
	0C	—	
	0D	TH03	Outdoor coil liquid Temp.
	0E	TH04	Outdoor coil gas Temp.
	0F	—	
	10	—	
	11	TH05	Outdoor air suction Temp.
	12	—	
	13	PC Compressor Current	
14	AC Compressor Current		

(PC or PC Comp. or Compressor : Power Control Compressor
 AC Comp. or AC Compressor : Standard Compressor

NOTE

In case there are no sensor equipped with the unit, - - - is shown on the display.

© Resetting the remote controller display to previous mode.

- To reset the display when you are finished, press **TEST / CHK** button, then the remote controller will return to previous mode.

(D) Find out about past service problems

The remote controller can memorize the **max. 4 most recent alarm messages**, so you can see problems the unit has had, if any. Knowing what has already occurred and been fixed helps you know what to check at present.

- This function is usable even if the unit is not working.
- To display the past error codes, follow the procedure below.

Procedure:

- a) On the remote controller, press both **TEST / CHK** and **SET** buttons at the same time for more than 4 seconds.
- b) Once in this mode, display changes from the normal display to service check display as shown in the table below:

NORMAL DISPLAY	Display Change (→)	SERVICE CHECK DISPLAY
Set temp.	→	Code No.
UNIT No.	→	UNIT No. (Indoor unit address)
Hours, Minutes	→	Alarm Message

1. Troubleshooting

This picture shows the service check display.

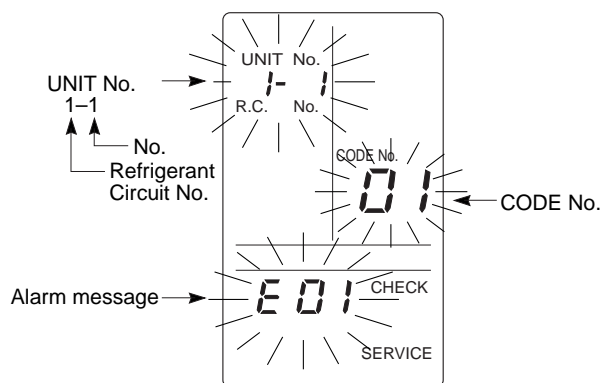

0358_M_I

©. A maximum of 4 alarm messages can be accessed by pressing either **SET TEMP** button ▲ or ▼ as follows.

MODE



Past

SET TEMP.

Present



Present

FAN SPEED

Past

NOTE Pressing **CL** (Clear) button will clear all the service history.

▲ ... accessed in order of "Past → Present".

▼ ... accessed in order of "Present → Past".

0359_M_I

For example, if the last four alarm messages were, in order of occurrence from oldest to most recent, **P01**, **P02**, **P04**, and most recently **E01**, then the display will be shown as below when you press ▼ button four times. The 5th time you press ▼ button you can repeat the display, then the first message will be shown again.

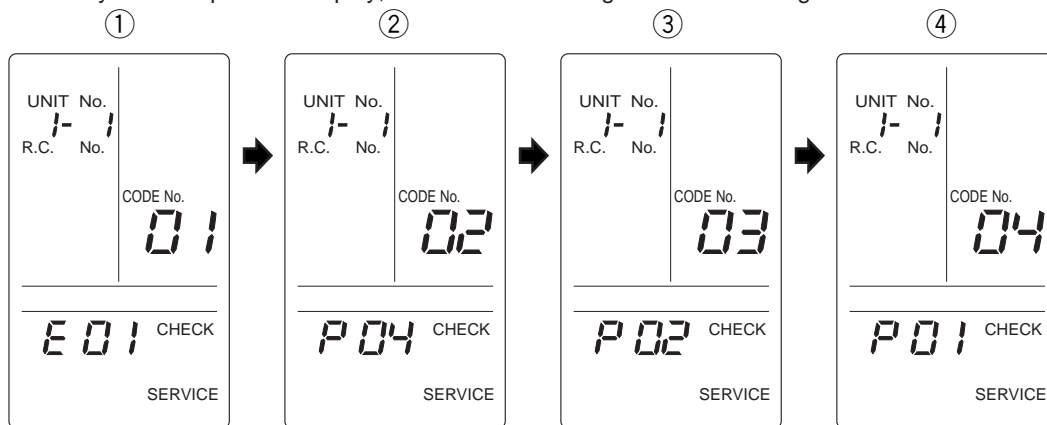

If there are no alarm messages, the display shows:

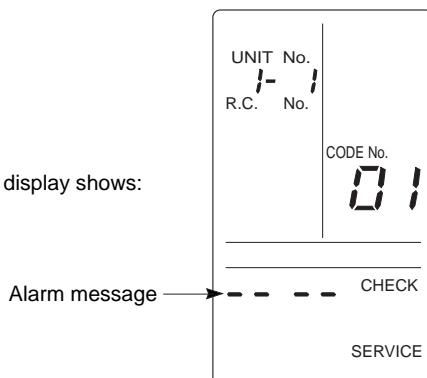

0360_M_I



1. Troubleshooting

Important

Never press **CL** (clear) button unless you want to erase the accessed data in memory. Follow the procedure below only when erasing is necessary.

- To erase accessed data, press the **CL** button.
- When erasing is finished, "----" mark appears on the controller's display.



After checking the alarm messages, be sure to press the **TEST / CHK** button.

(E) Check the remote controller itself for correct operation

The remote controller has a **self-diagnostic** function to check if it works properly. Use this procedure to find out if the remote controller itself is in trouble.

- a) Turn ON the **RCU.CK** switch on the back of the **P.C.B.** Ass'y in the remote controller. See section **(A)** for exact location.
- b) The appearance of the display will tell you whether or not the remote controller is working correctly or not.
 - Normal condition** – All displays appear for 10 seconds, then disappear.
 - Unusual condition** – All displays flash ON and OFF for 10 seconds, then disappear.



After checking the panel, be sure to set the **RCU.CK** switch to this original **OFF** position.

1. Troubleshooting

(F) Execute the auto. address operation

- Auto. address operation is executed by pressing the A. ADD button of outdoor unit's PCB usually (See "Test Run" V-2 ~).
For your convenient it can be executed by remote controller also.

- a) Press the **TEST / CHK** and **▲ (⊕)** buttons at the same time for more than 4 seconds.
- b) Set CODE No. A1 with **▲** , **▼ (SET TEMP)** button.

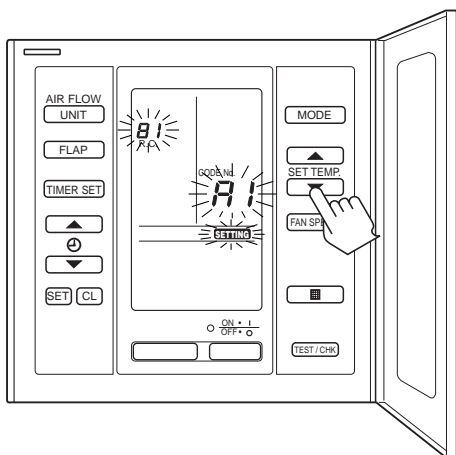

In this mode, the auto. address operation is executed at each R.C. (Refrigerant Circuit) line one by one.

- c) Select R.C. No. which you want to execute the auto. address operation with **UNIT** button.
- d) Press the **SET** button. The auto. address operation will start. CODE No. changes from flashing to ON state.
- e) If an error occurs during operation, the alarm message will be displayed. Check and remove the cause. If you want to stop the operation, press the **CL** button then the unit stands in waiting mode (Press the **SET** button again.)
- f) If the automatic address operation finishes, the display will disappear.
- g) Execute the operation of the other R.C. line in the same way by following the above steps c) to d) .
- h) Complete the automatic address operation by pressing the **TEST / CHK** button.

1. Troubleshooting

(G) Confirm and change the indoor unit address

- The purpose of the above function is to let you confirm the indoor unit address after the auto. address operation, and change the indoor unit address if it is needed.

- a Press the **TEST / CHK** and **▼ (⏻)** buttons at the same time for more than 4 seconds.

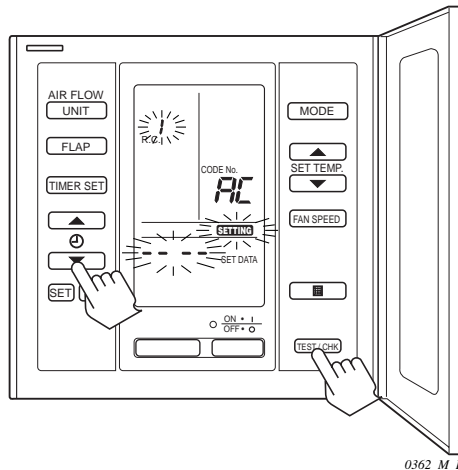

- b Select the R.C. No. which you want to change with the **UNIT** (up) or **FLAP** (down) buttons.

- c Press the **SET** button (to confirm the R.C. No.).
The smallest registered indoor No. and the selected R.C. No. will be displayed.

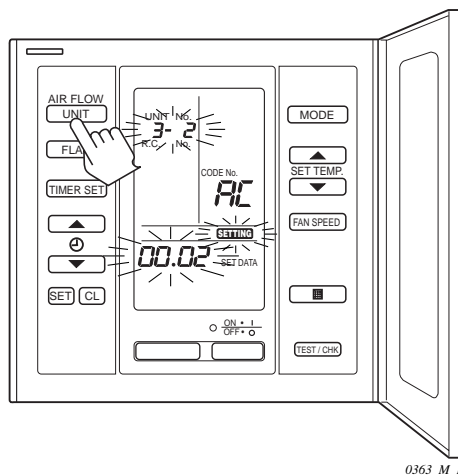

Ex:

R.C. No. 3 is selected.

Indoor No. 2 is the smallest indoor No. of the R.C. No. 3.

- d Select the indoor No. which you want to change with **UNIT** button. Once in this mode, **the fan motor of selected indoor unit will turn on and let you confirm the indoor unit address.**

1. Troubleshooting

- Ⓔ Set the required new indoor unit's No. by pressing the ▲ , ▼ (⊕) button.

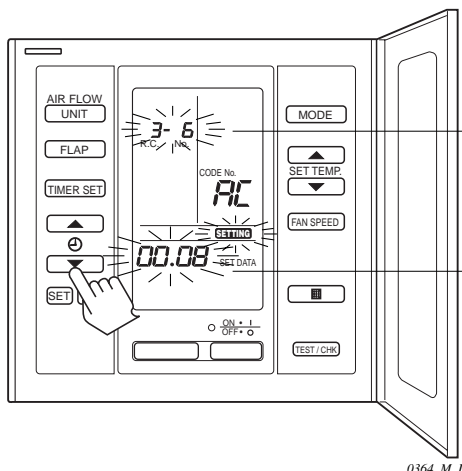

Ex: UNIT No. 3-6: currently registered indoor unit address

Required new indoor No.8: SET DATA

* In this case, UNIT No. 3 – 6 (current)
 ≠
 3 – 8 (NEW : after pressing the
TEST / CHK button)

- Ⓕ Press the SET button.
 UNIT No, SET DATA (0008) and **SETTING** changes from flashing to ON state.
- Ⓖ If you make mistake press the **CL** button.
- Ⓗ Finally, press the **TEST / CHK** button.
- Ⓘ If you want to change the indoor unit address of the other R.C. No., follow the step Ⓔ to Ⓗ in the same way.



1. Troubleshooting

(H) Change the shift temperature in heating mode

- ❑ If the indoor unit is installed at high location (ex. ceiling level), the thermostat tends to turn off at heating mode because of the hot air temperature around ceiling level. In order to solve the problem, the shift temp. (valid while heating only) is set when shipped from factory.
- ❑ If the shift temp. is not enough (ex. the indoor unit is installed at position higher than 3 m), the shift temp. can be set with remote controller from +1 to +10 deg. manually as follows:

- a) Press the **TEST / CHK** button for more than 4 seconds.

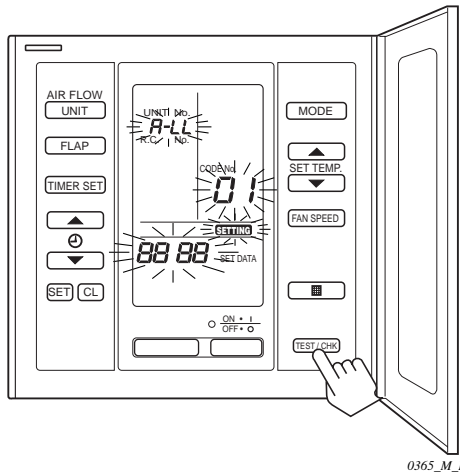

0365_M_1

- b) In case of group control, if you want to change all units in group control collectively, proceed next step remaining ALL displayed. If you want to change a unit individually, select the indoor unit address (UNIT No.) with **UNIT** button.
- c) Select the CODE No. 06 with ▲ , ▼ (**SET TEMP**) button.
- d) Choose the shift temp with ▲ , ▼ (⊕) button.

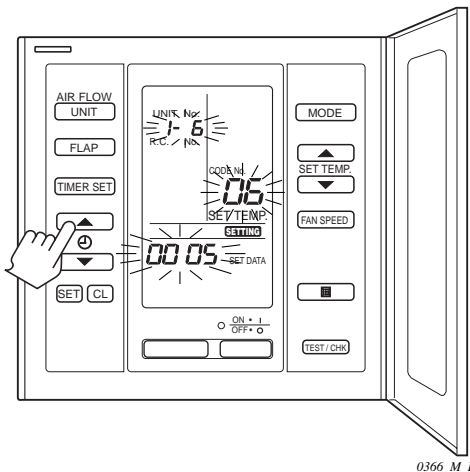

0366_M_1

EX:
 UNIT No. 1-6
 CODE No. 06
 Shift temp. +5 deg

- e) Press the **SET** button.
 CODE No. 06, SET DATA and **SETTING** change from flashing to ON state.
- f) If you made mistake, press the **CL** button.
- g) Finally, press the **TEST / CHK** button.

1. Troubleshooting

(I) Set the indoor unit address

- ❑ This function is usable if the auto. address operation is not available.
Indoor unit address can be set one by one by remote controller in such case.

NOTE

- 1) In case of group control, branch wiring for group control should be removed temporarily.
- 2) In case of remote controllerless system, remote controller should be connected with the indoor unit temporarily.

- a) Short the two terminals of DISP PIN on indoor unit PCB.
(DISP PIN : Refer to P. VI-2)
- b) Press the **TEST / CHK** , **SET** and **CL** buttons at the same time for more than 4 seconds.

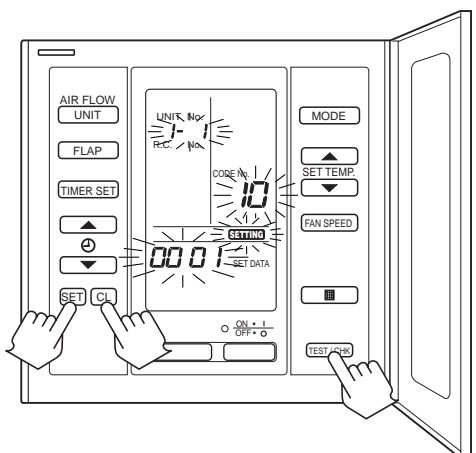

0367_M_I

- c) Set the CODE No. 12 to set the No. of R. C. with the ▲ , ▼ (**SET TEMP**) button.

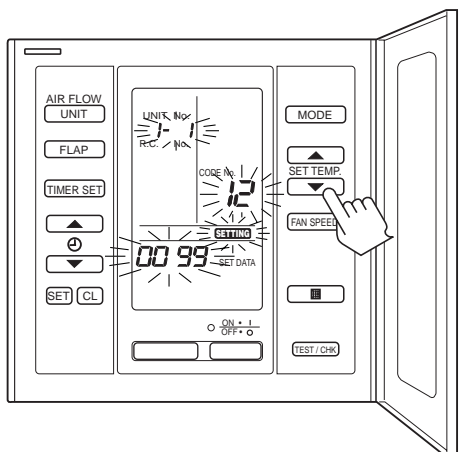

0368_M_I

1. Troubleshooting

- d Set the No. of R. C. which you want to set with ▲ , ▼ (⊕) button.

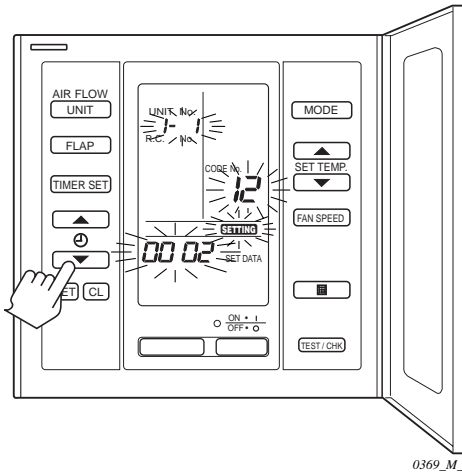

Ex. No. of R. C. will be set 2.

- e Press the **SET** button.
UNIT No., CODE No. 12, **SETTING** and SET DATA (0002) change from flashing to ON state.
- f Select the CODE No. 13 to set the indoor unit No. with the ▲ , ▼ (**SET TEMP**) button.
- g Set the indoor unit No. which you want to set with the ▲ , ▼ (⊕) button.

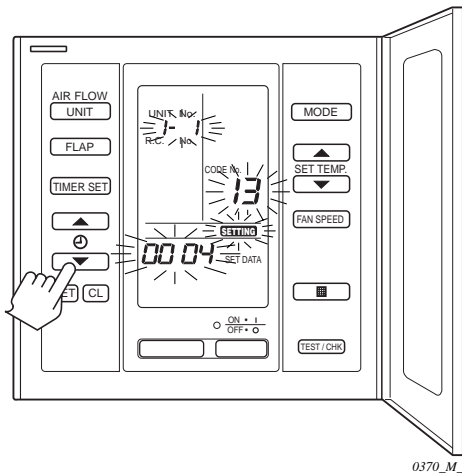

Ex. Indoor unit No. 4 will be set.
In this example, indoor unit address (UNIT No.) will be set 2-4.

- h Press the **SET** button.
UNIT No., CODE No. 13, **SETTING** and SET DATA (0004) change from flashing to ON state.

1. Troubleshooting

- ① Select the code No. 14 to set group setting with the ▲ , ▼ (SET TEMP) button.
- ② Set the No. of group setting as shown below with the ▲ , ▼ (⊕) button.

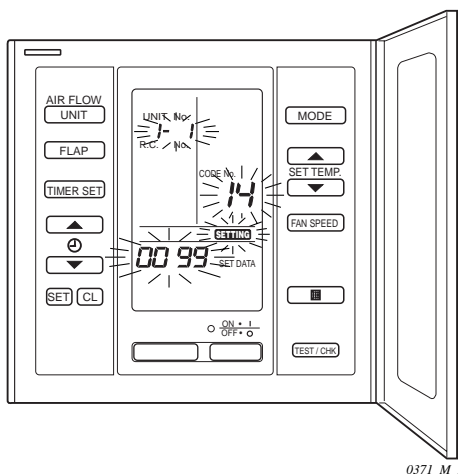

0371_M_1

Nos. of group setting.

- 0 : Standard system (except group control)
- 1 : Main indoor unit in case of group control
- 2 : Sub indoor unit in case of group control
- 99 : No setting (at factory shipment)

- ③ Press the **SET** button.
UNIT No., CODE No. 14, **SETTING** and SET DATA change from flashing to ON state.
- ④ If you made mistake, press the **CL** button so that setting returns to the initial state.
- ⑤ Press the **TEST / CHK** button to finish this mode.
The display is disappeared.
- ⑥ Confirm the indoor unit address (UNIT No.) with the **UNIT** button after pressing the **ON / OFF** button.
- ⑦ Finally, remove the short circuit of DISP PIN.
And in case of group control, be sure to restore the branch wiring to its original wiring. In case of remote controller-less system, remove the remote controller.

1. Troubleshooting

(J) Change the period of the filter timer

- If the period of filter timer is not suitable (for example in case of dirty environment), the period can be shortened to half as follows:

- ① Press the **TEST / CHK** button for more than 4 seconds.

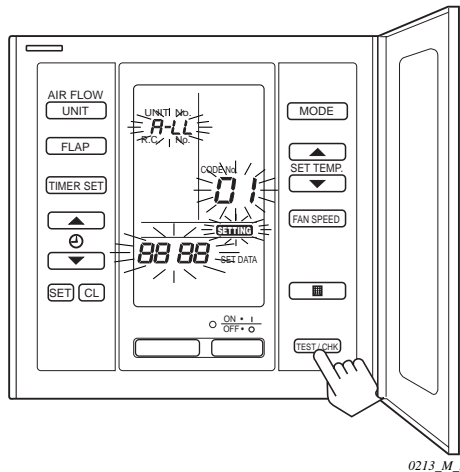

0213_M_I

- ② In case of group control, if you want to change all units in group control collectively, proceed next step remaining "ALL" displayed.

If you want to change a unit individually, select the indoor unit address (UNIT No.) with **UNIT** button.

- ③ Select the CODE No. 02 with ▲ , ▼ (**SET TEMP**) button.

- ④ Change the No. from 0 to 1 with ▲ , ▼ (⊖) button.

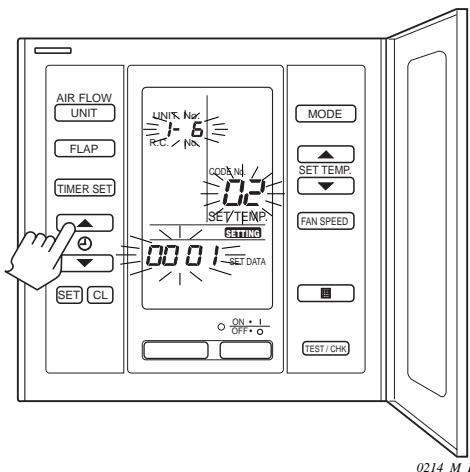

0214_M_I

EX:

UNIT No. 1-6
 CODE No. 02
 { X, S, T, SL type 2,500 hr → 1,250 hr
 AS, K, F, FM type 150 hr → 75 hr

- ⑤ Press the **SET** button.
 CODE No. 06, SET DATA and **SETTING** change from flashing to ON state.

- ⑥ If you make mistake, press the **CL** button.

- ⑦ Finally, press the **TEST / CHK** button.

3

2. Sensor and Solenoid Layout Diagram

2-1. Outdoor unit

- SPW-CR363GVH8, SPW-CR363GV8
- SPW-CR483GVH8, SPW-CR483GV8

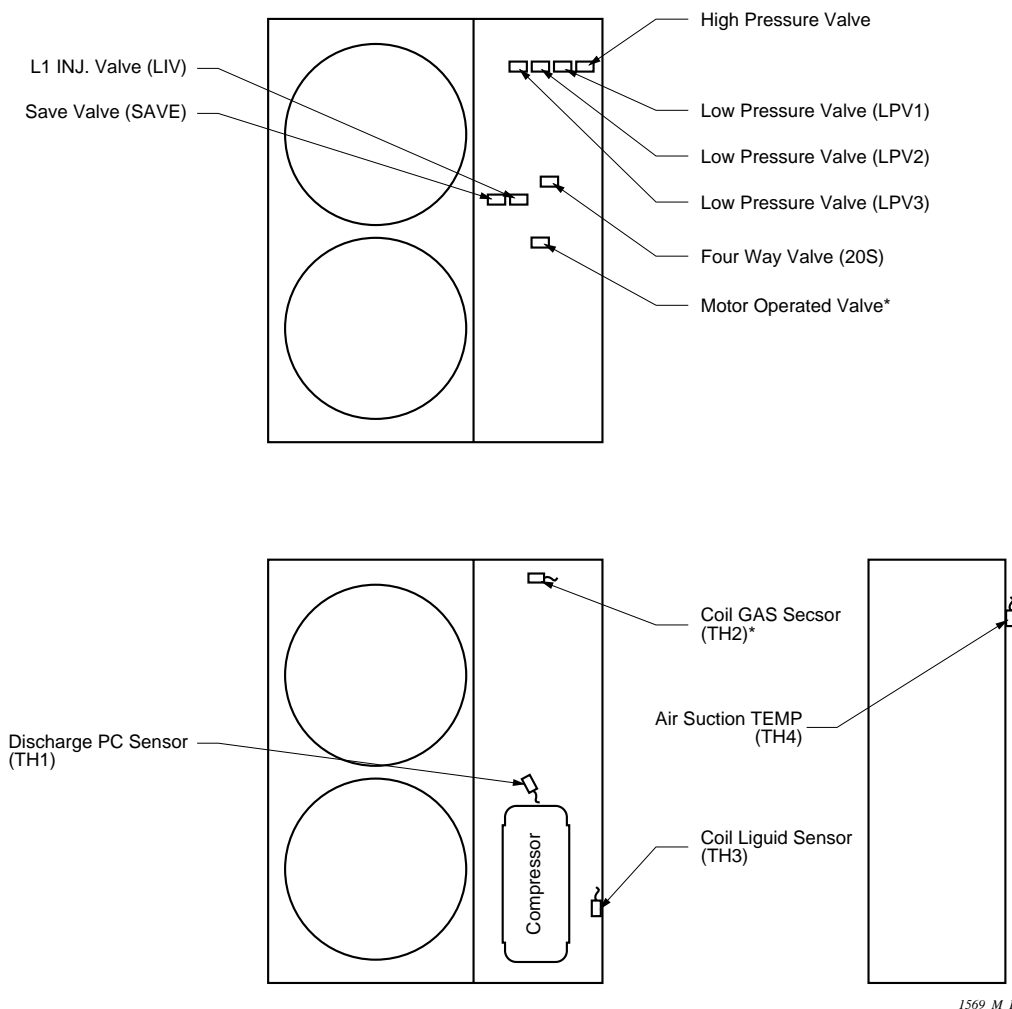

1569_M_1

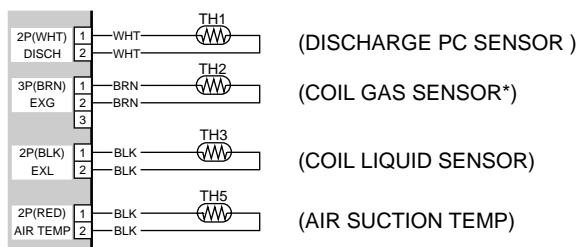

1570_THS_1

Note) * is only for Heat pump type

2. Sensor and Solenoid Layout Diagram

■ SPW-CR703GVH8, SPW-CR903GVH8

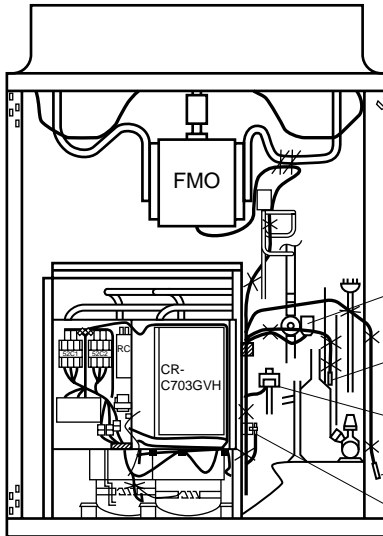

4-Way valve
(20S), (WHT)

TH4 (BRN)

Motor operated
valve (MOV)

TH3 (BLK)

TH5 (RED)

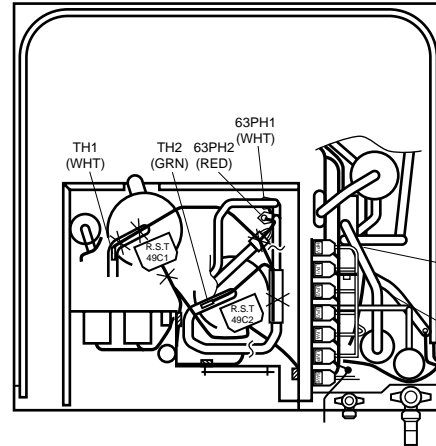

4-Way valve
(20S), (WHT)

TH4 (BRN)

1232_D_1

1233_D_1

CN84	1	WHT	TH1	(PC DISCHARGE GAS TEMP)
	2	WHT		
CN85	1	WHT	TH2	(AC DISCHARGE GAS TEMP)
	2	WHT		
CN81	1	BLK	TH3	(COIL LIQUID TEMP)
	2	BLK		
CN82	1	BRN	TH4	(COIL GAS TEMP)
	2	BRN		
	3			
CN80	1	BLK	TH5	(SUCTION AIR TEMP)
	2	BLK		

1234_THS_1

■ SPW-CR703GV8, SPW-CR903GV8

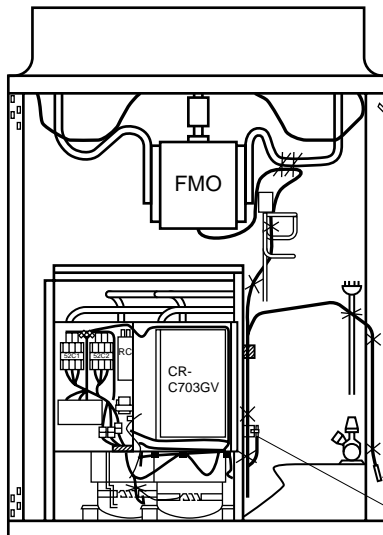

TH3 (BLK)

TH5 (RED)

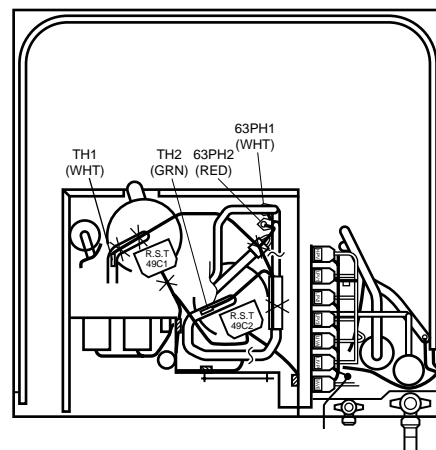

4-Way valve
(20S), (WHT)

TH4 (BRN)

1235_D_1

1236_D_1

CN84	1	WHT	TH1	(PC DISCHARGE GAS TEMP)
	2	WHT		
CN85	1	WHT	TH2	(AC DISCHARGE GAS TEMP)
	2	WHT		
CN81	1	BLK	TH3	(COIL LIQUID TEMP)
	2	BLK		
CN80	1	BLK	TH5	(SUCTION AIR TEMP)
	2	BLK		

1237_THS_1

2. Sensor and Solenoid Layout Diagram

2-2. Indoor unit

- SPW-XR123GH56
- SPW-XR183GH56
- SPW-XR253GH56

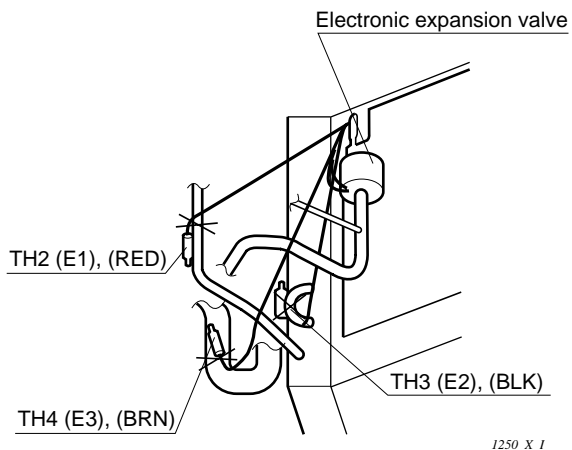

- SPW-XR363GH56
- SPW-XR483GH56

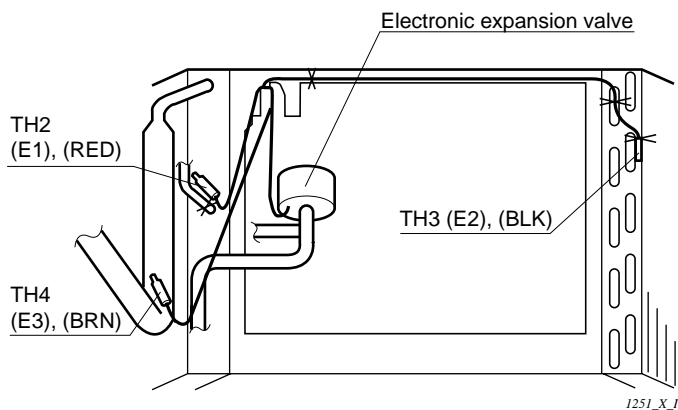

- SPW-SR93GH56
- SPW-SR123GH56
- SPW-SR183GH56

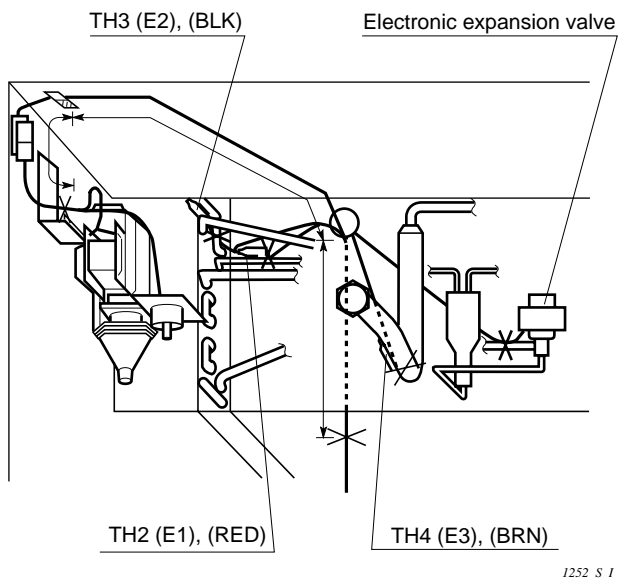

- SPW-SR253GH56

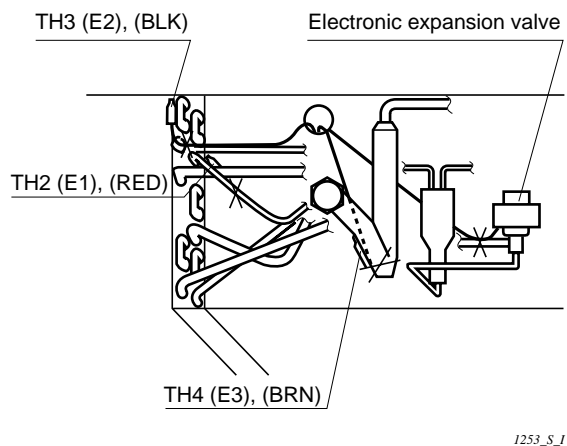

3

2. Sensor and Solenoid Layout Diagram

■ SPW-ASR93GH56

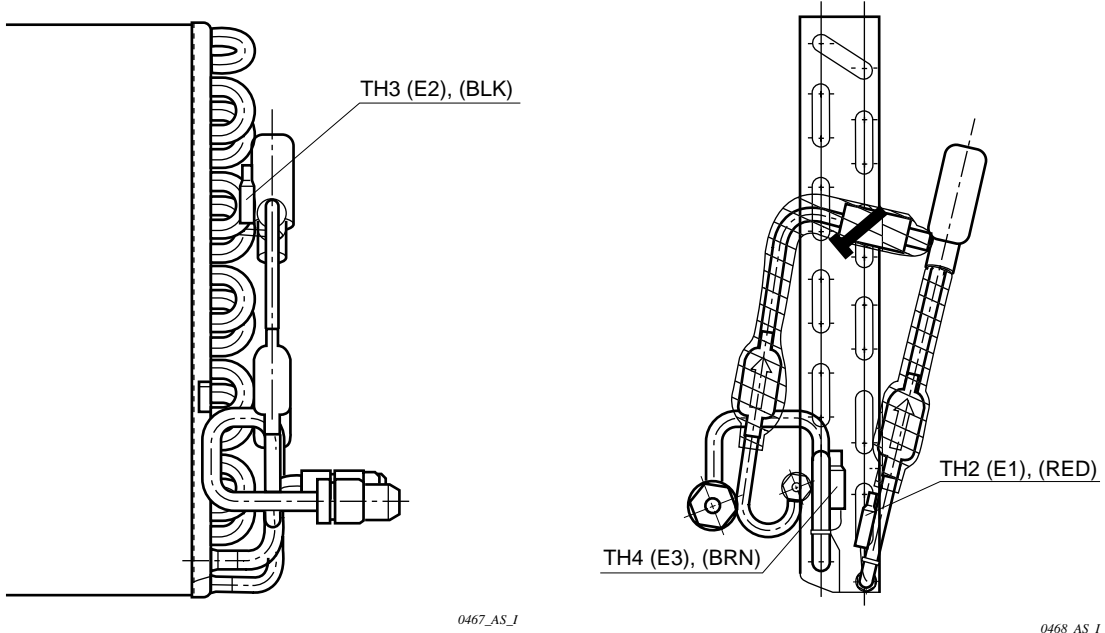

■ SPW-ASR123GH56

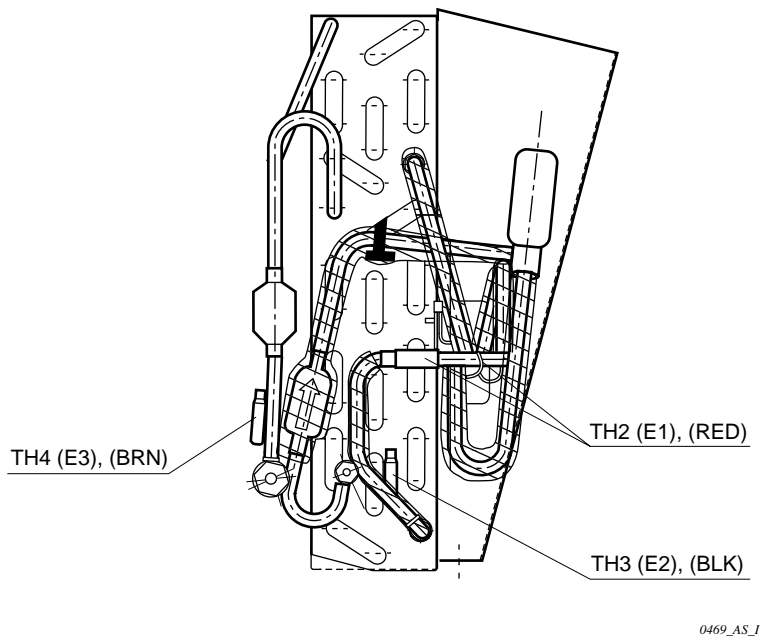

3

2. Sensor and Solenoid Layout Diagram

- SPW-KR93GH56
- SPW-KR123GH56
- SPW-KR183GH56

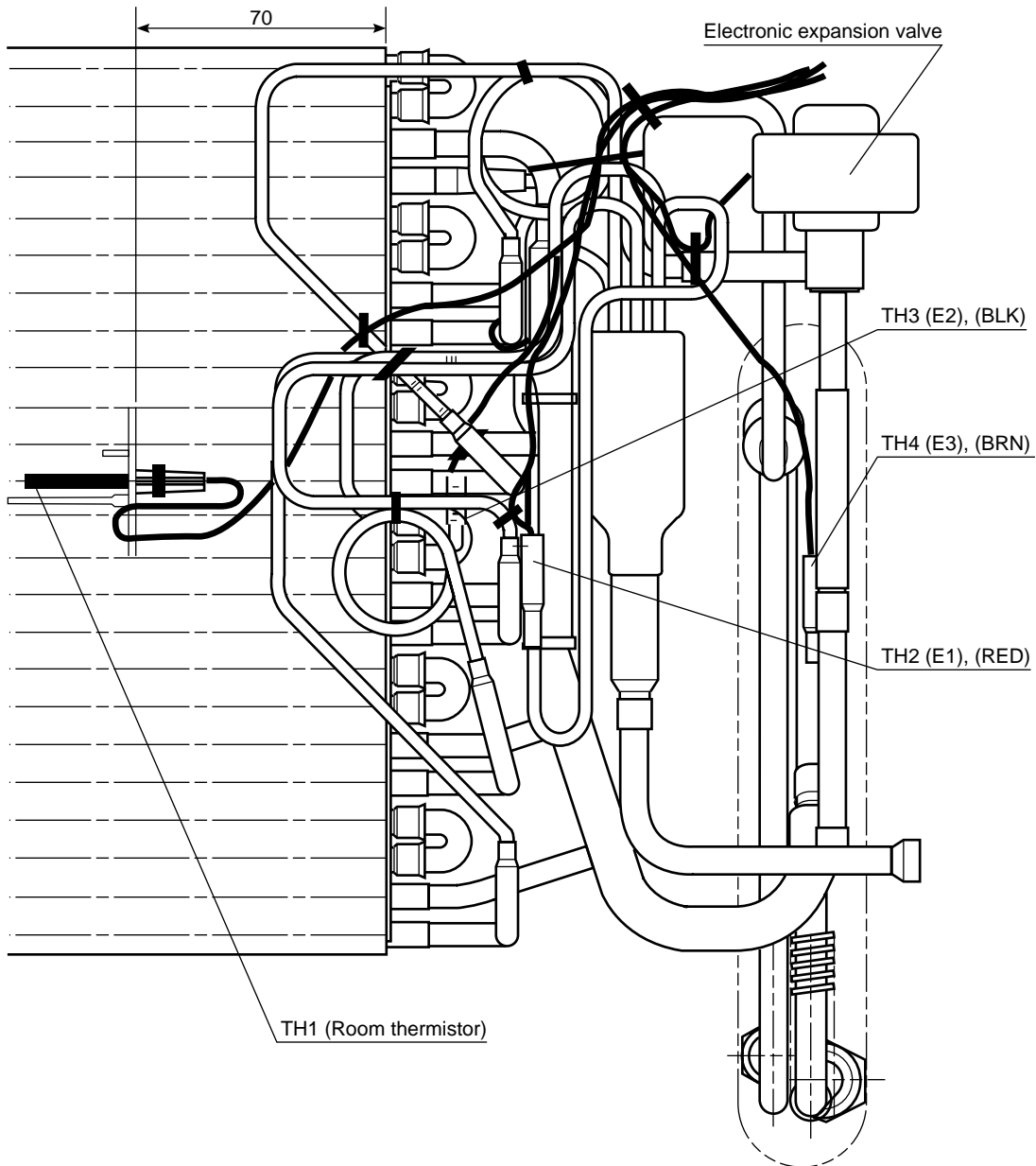

1254_K_J

3

2. Sensor and Solenoid Layout Diagram

■ SPW-TR183GH56

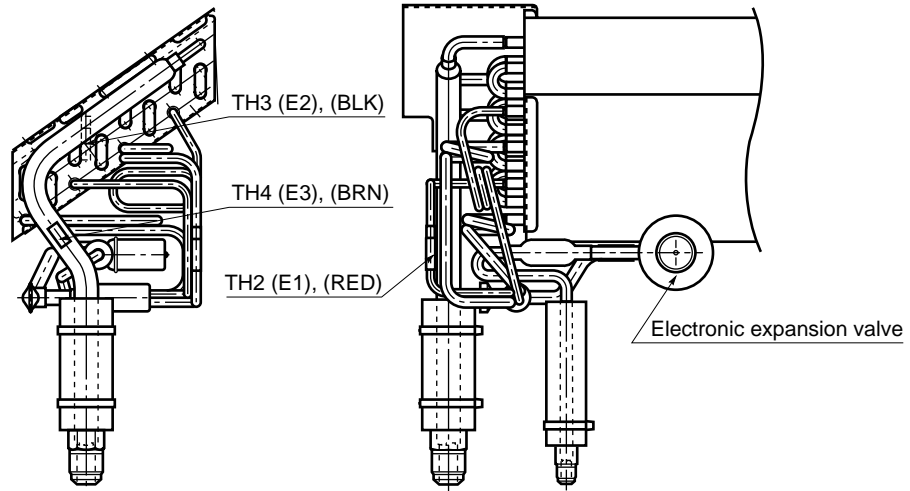

1217_THS_I

■ SPW-TR253GH56

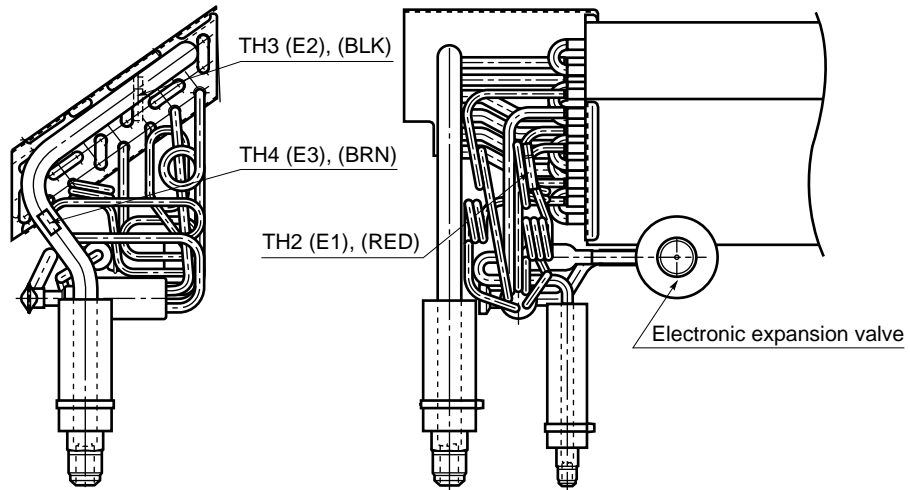

1218_THS_I

■ SPW-TR363GH56, SPW-TR483GH56

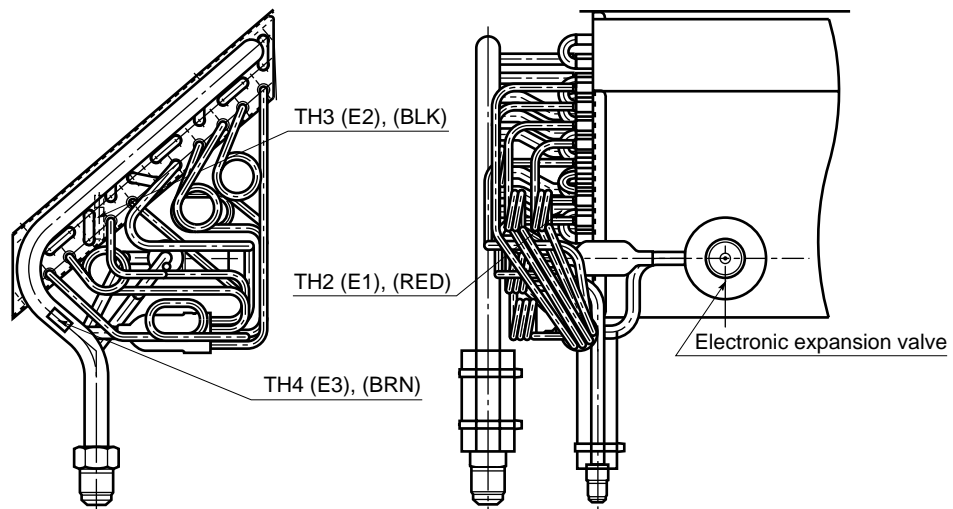

1219_THS_I

SM830063

2. Sensor and Solenoid Layout Diagram

■ SPW-DR253GH56

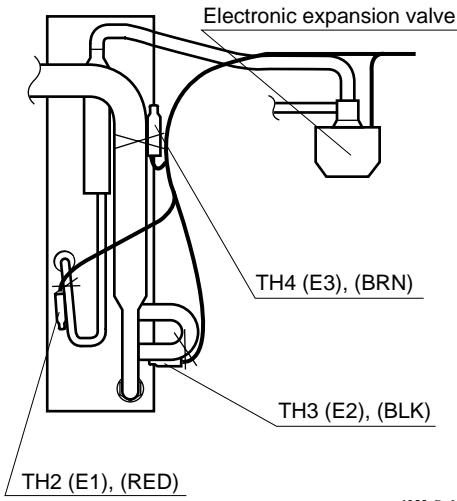

■ SPW-DR363GH56
■ SPW-DR483GH56

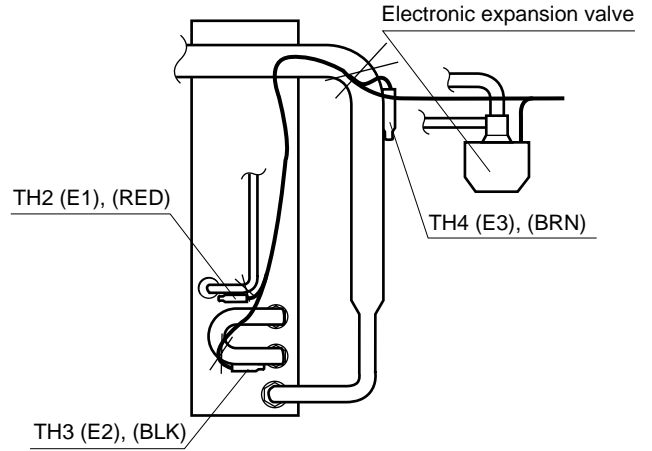

1256_D_I

1255_D_I

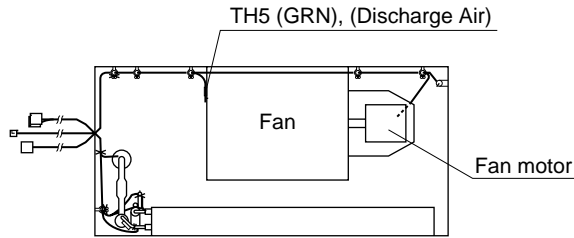

1263_C_I

■ SPW-UR93GH56
■ SPW-UR123GH56
■ SPW-UR183GH56
■ SPW-UR253GH56

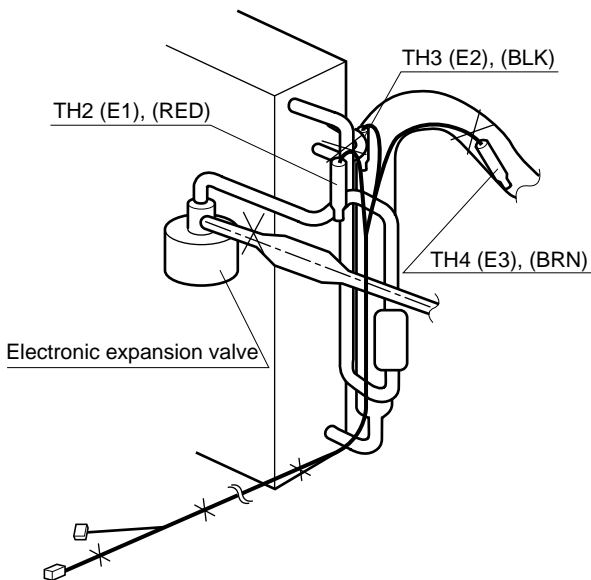

1257_U_I

■ SPW-UR363GH56
■ SPW-UR483GH56

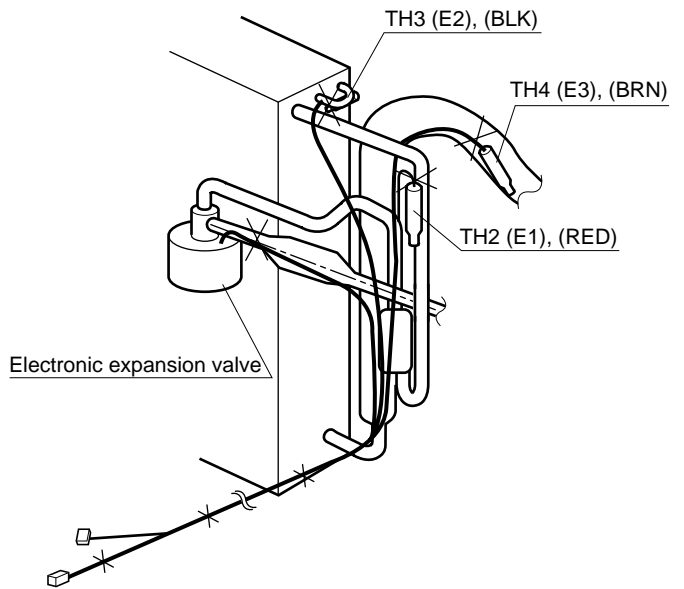

1258_U_I

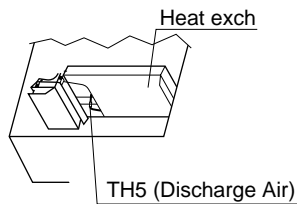

1264_C_I

3

2. Sensor and Solenoid Layout Diagram

- SPW-FR93GH56, SPW-FR123GH56
- SPW-FMR93GH56, SPW-FMR123GH56

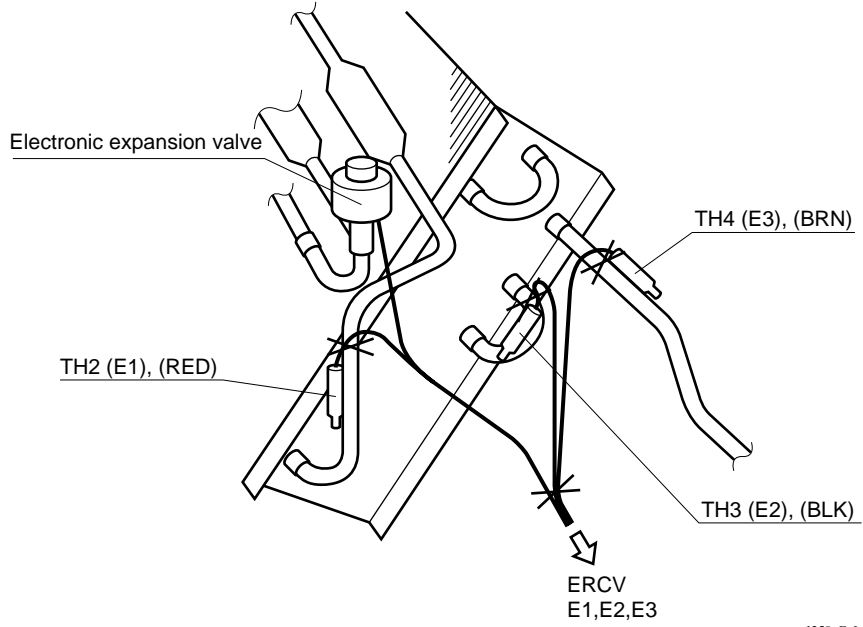

1259_F.1

3

- SPW-FR183GH56, SPW-FR253GH56
- SPW-FMR183GH56, SPW-FMR253GH56

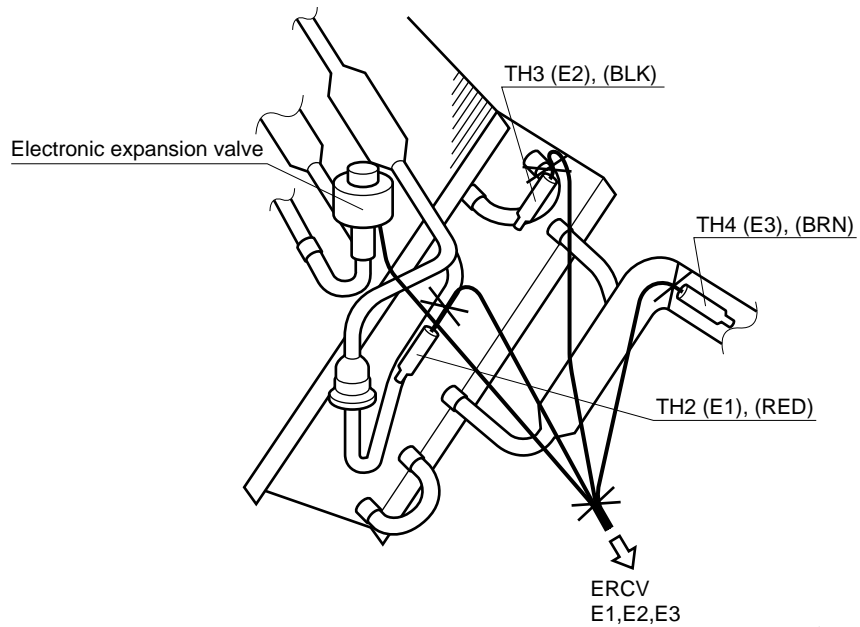

1260_F.1

2. Sensor and Solenoid Layout Diagram

■ SPW-SLR93GH56, SPW-SLR123GH56

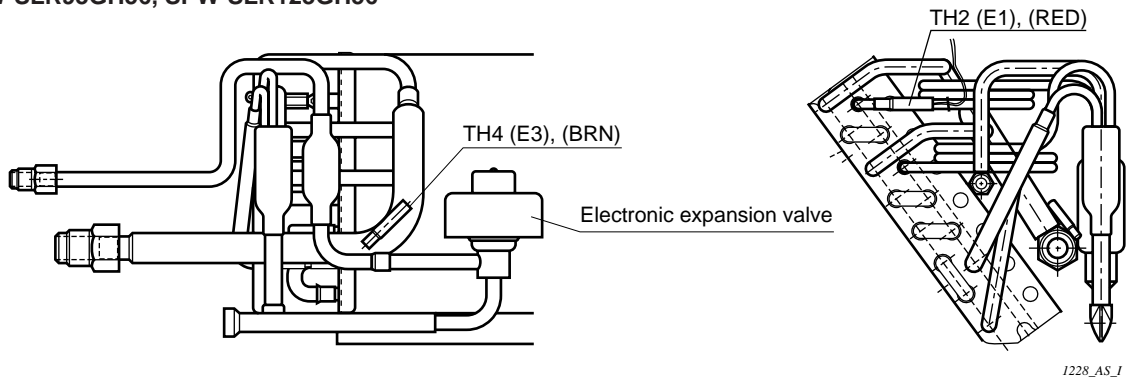

■ SPW-SLR183GH56

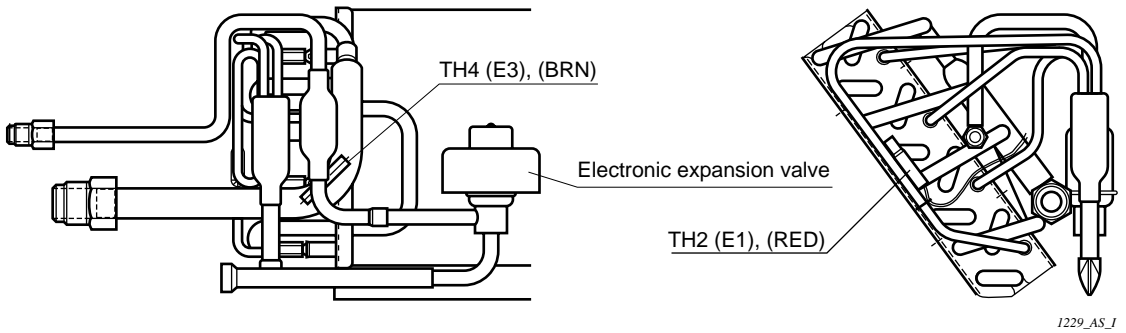

■ SPW-SLR253GH56

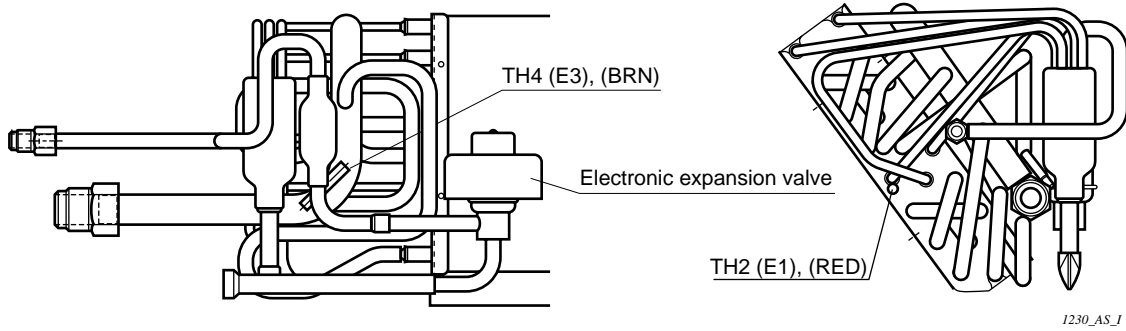

- SPW-SLR93GH56
- SPW-SLR123GH56

- SPW-SLR183GH56

- SPW-SLR253GH56

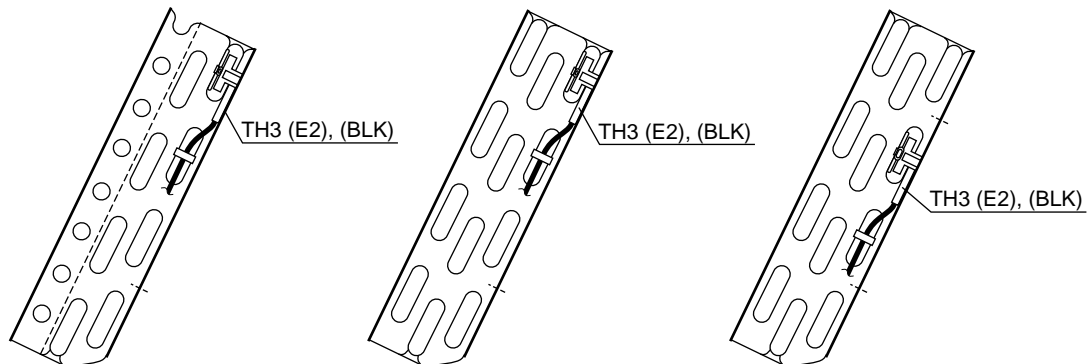

3. Thermistor Characteristic Curve

- (1) Indoor room temp. sensor : TH1
 Indoor discharge air temp. sensor : TH5

- (2) Indoor heat exch. coil sensor : TH2(E1), TH3(E2), TH4(E3)
 Outdoor heat exch. coil sensor : TH2, TH3 (36, 48 Type)
 TH3, TH4, TH5 (70, 90 Type)

KTEC-35

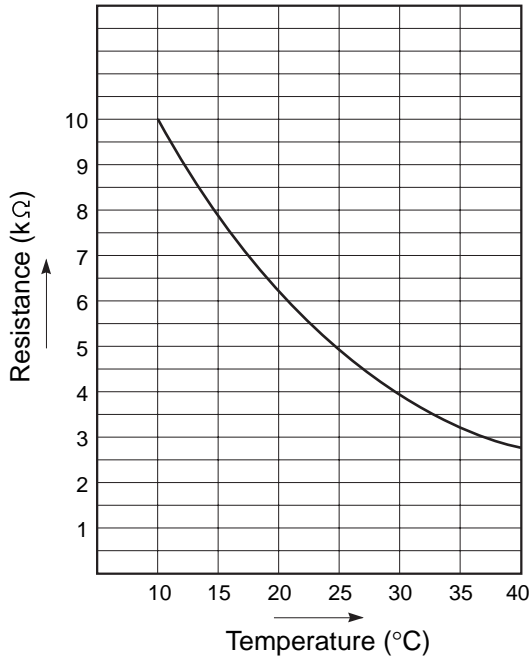

PBC-41E, PB3M-41E

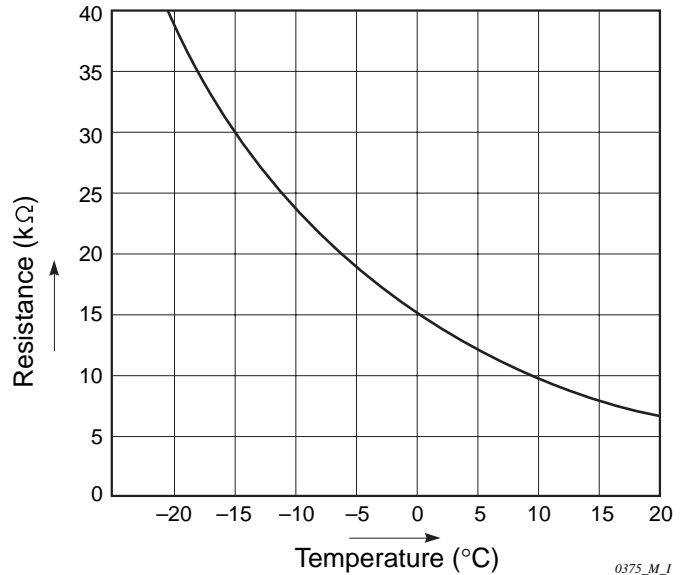

3

- (3) Compressor discharge gas temp. sensor : TH1 (PC Compressor) (36, 48 Type)
 Compressor discharge gas temp. sensor : TH1 (PC Compressor), TH2 (AC Compressor) (70, 90 Type)

PTC-51H

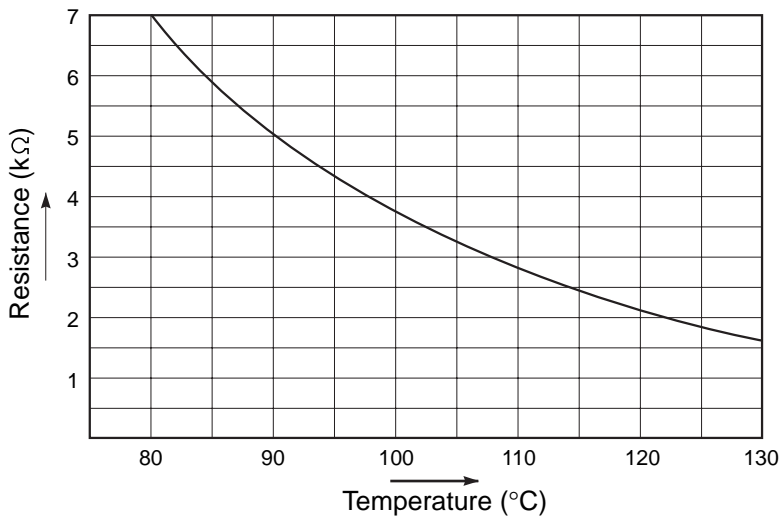

4. Test Run

4-1. PCB Setting & Test Run

● Setting of outdoor PCB

(A) Set the number of indoor units which are connected to the outdoor unit in S004.

- ① For example in the case of 13, set "D" in S004.
- ② If the number of indoor units and the number of set switches are identical, the LED: 1 to 8 (9~16) light up matching the number of indoor units.
- ③ If the outdoor alarm LED (yellow) and LED: 2, 3, 6 light up when operating the indoor unit, it is a combination fault. Check the number of connected indoor units.
*(Remote controller shows the alarm of display).

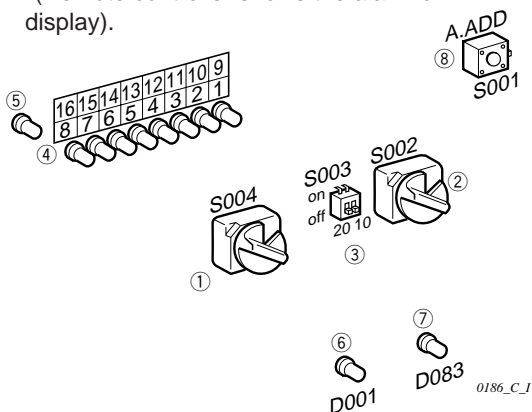

- ① S004 (RED) : Setting SW for number of indoor units (0~16 or 1~10).
- ② S002 (BLK) : Setting SW for R.C. address of the outdoor unit (0~9).
- ③ S003 : Setting SW for R.C. address of the outdoor unit (10, 20).
- ④ RED LED 1 ~ 8 : Message lamp
- ⑤ RED LED (9 ~ 16) : Message lamp (only for 70, 90 type)
- ⑥ D001 (RED) : Power lamp
- ⑦ D083 (Yellow) : Outdoor unit alarm lamp
- ⑧ S001 : A. ADD (Auto. address) button

(B) When linking outdoor units in a network (S-net link system).

- ① Set the R.C. address number of the outdoor unit in S002 and S003.
R.C. address : Refrigerant circuit address 1~30.
- ② Remove the short plug (CN031, 2P Black, location: right bottom on the outdoor control PCB) from all outdoor units except one.

For a system without link, set the R.C. address number to 1 and retain the short plug CN031.

Example,

R.C. address	S002	S003		CN031
		20	10	
1	1	off	off	short (In case of No-link system)
12	2	off	on	open (In case of link system)
23	3	on	off	open (In case of link system)

● Setting the indoor PCB

No setting necessary.

Each indoor unit address (UNIT No: R.C. - No.) is decided after auto. address operation.

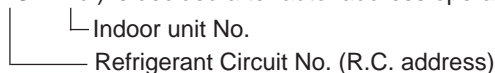

Manual setting for indoor unit address can be performed also by remote controller.

● Check items before the test run

- ① Turn on all power supply switches more than 5 hours before in order to charge the crank-case heater.
- ② Fully open the outdoor service valve after making the leak inspection of field connected tubing, vacuuming, and gas charging.



4. Test Run

● Test run procedure

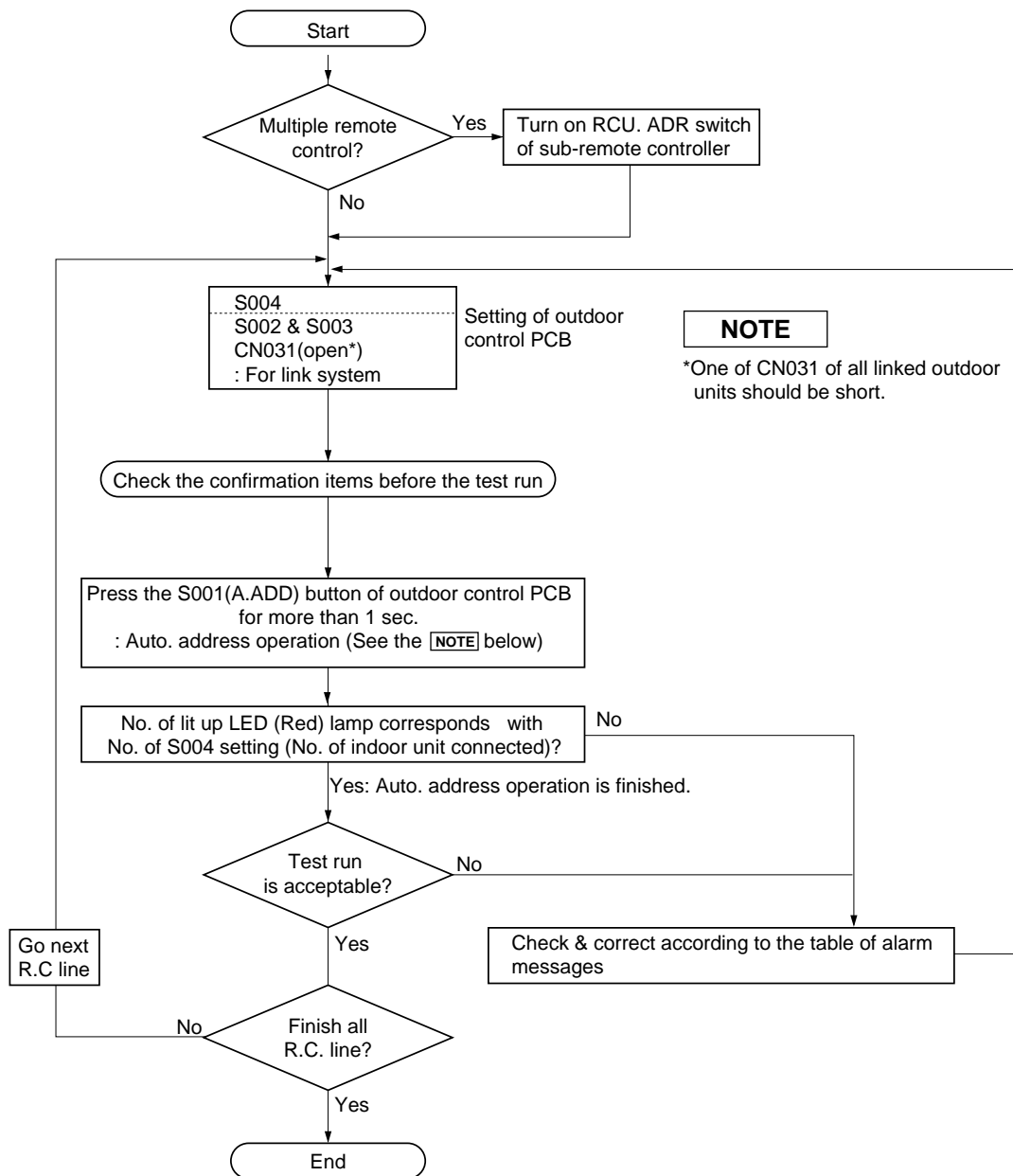

0812_M_1

NOTE

- 1) Auto. address operation decides each indoor unit address to the indoor unit connected to the refrigerant circuit individually.
The required time of operation depends on the temperature.
It takes a maximum of 20 minutes for a link system.
It takes a maximum of about 3 minutes without turning on the compressor, for a system without link.
- 2) When linking outdoor units in a network (link system), Auto. address operation should be performed by each refrigerant circuit (outdoor unit) individually. If you start Auto. address operation of another refrigerant circuit during Auto. address operation, the alarm message (E12) will be displayed.
- 3) Indoor unit address can be changed manually with the remote controller when required.
- 4) The selected indoor unit address is memorized in EEPROM even after power failure.
- 5) When using a system controller, zone registration is required after finishing the test run.

4. Test Run

4-2. Main Alarm Messages which Indicate Mis-Wiring & Mis-Setting

Remote controller display	Cause		
	Individual Remote Control	Group Control	Multiple Remote Control
Nothing displayed	<ul style="list-style-type: none"> Remote controller not properly connected. Power supply not ON. 		
E1	<ul style="list-style-type: none"> Remote controller not properly connected. 		
E4	<ul style="list-style-type: none"> Wiring connection fault of indoor/outdoor units 	<ul style="list-style-type: none"> Wiring connection fault of some indoor/outdoor units inside the group 	
	<ul style="list-style-type: none"> Power supply of outdoor unit not ON. 		
E6	<ul style="list-style-type: none"> Combination of indoor/outdoor units is wrong. * Incorrect setting of No. of indoor unit on outdoor control PCB. (S004 setting) * Power supply of some indoor units not ON. 		
E9	—	—	<ul style="list-style-type: none"> 2 main remote controllers set.
P9 (*)	<ul style="list-style-type: none"> Improper wiring connections of ceiling panel 		

* Ref: Alarm "P9" is not generated if the remote controller is set at test run.

4-3. Main Alarm Messages Indicating Unit Malfunction

	Fault detected	Remote controller display
Indoor protection	Fan motor protection thermostat	P1
Outdoor protection	Fan motor protection thermostat	P2
	Compressor protection thermostat	
	Incorrect discharge temp of PC (AC) comp.	P3 (P17)
	High-pressure switch	P4
Indoor protection	Float switch	P10
Indoor sensor	Open/or damaged	F1-F3, F10, F11
Outdoor sensor	Open/or damaged	F4 ~ F8
Compressor protection	PC comp. motor is overloaded.	H1
	PC comp. motor is locked.	H2
	AC comp. motor is overloaded.	H11
	AC comp. motor is locked.	H12

NOTE

- comp.: Compressor
- temp.: Temperature
- PC: Power Control
- AC: Standard

5. PCBs illustrations

■ PCB (CR-X253GH) for indoor units

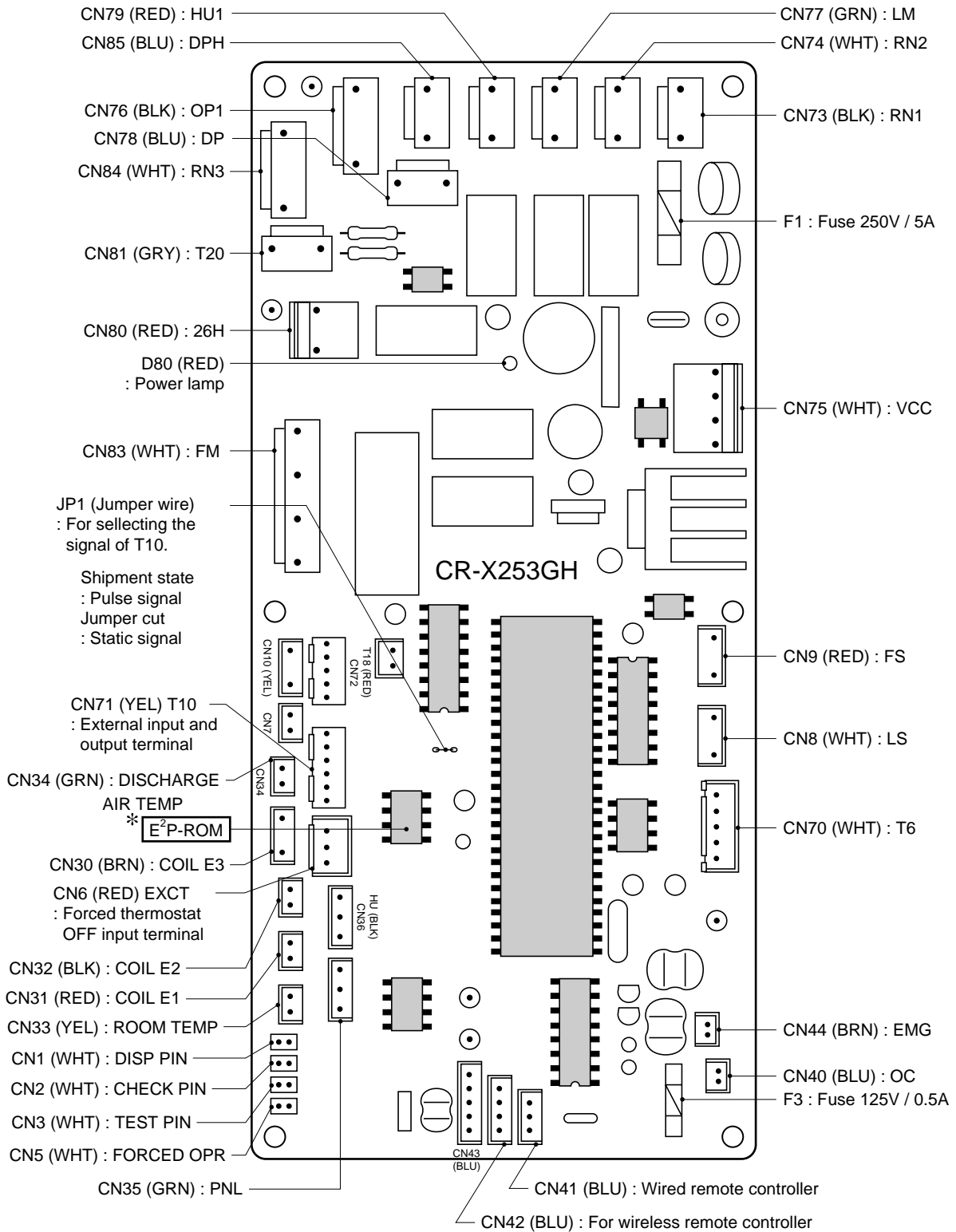

1208_THS_J

Note when replacing the indoor unit PCB

When replacing the indoor unit PCB for service, remove the *E²P-ROM of the original PCB then attach it to the new PCB since the original E²P-ROM has it's own data (ex. indoor unit address) to identify the unit.

5. PCBs illustrations

Outdoor unit control PCB (CR-CR483GVH)

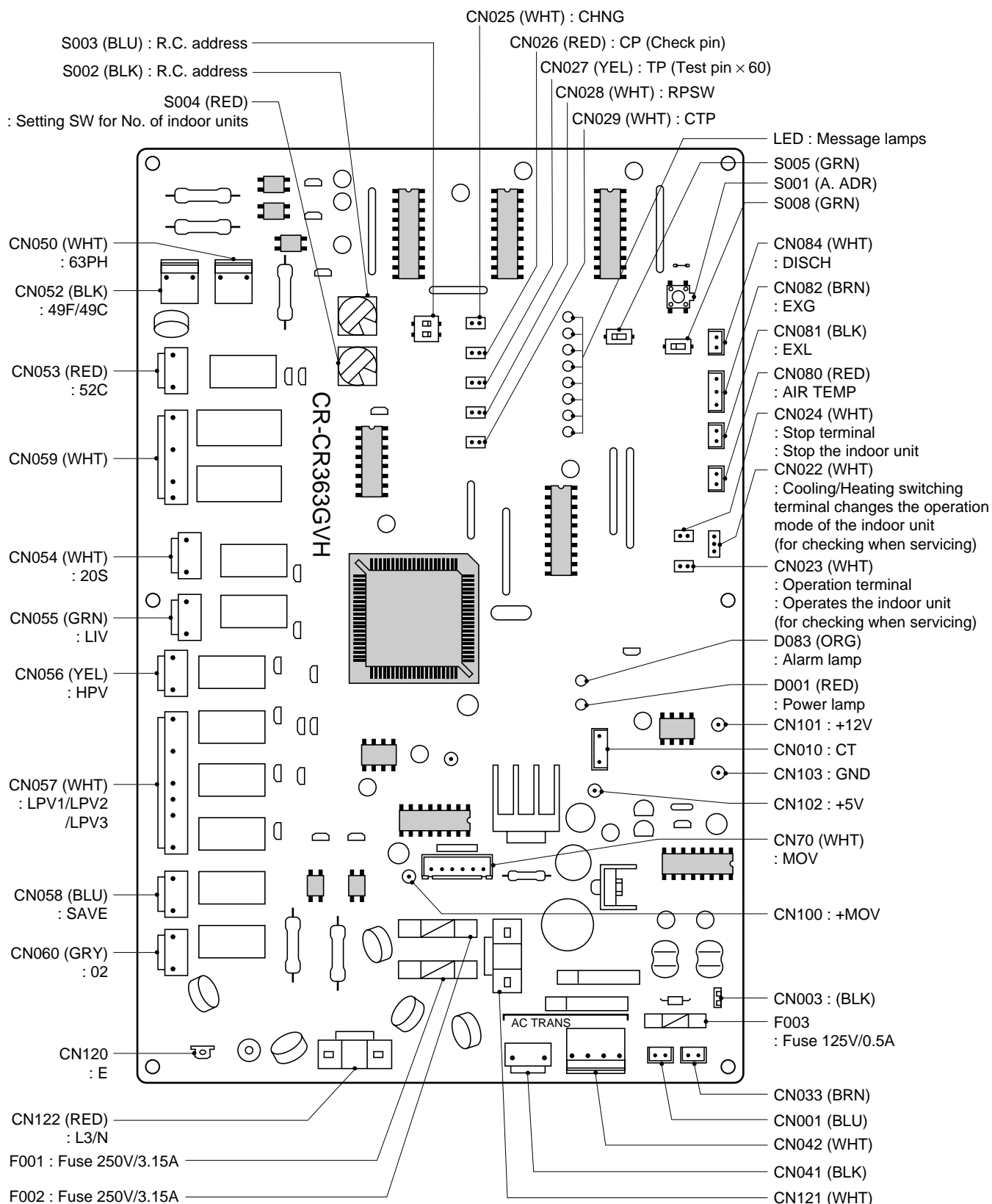

1487_THS_1

5. PCBs illustrations

Outdoor unit control PCB (CR-CR703GVH)

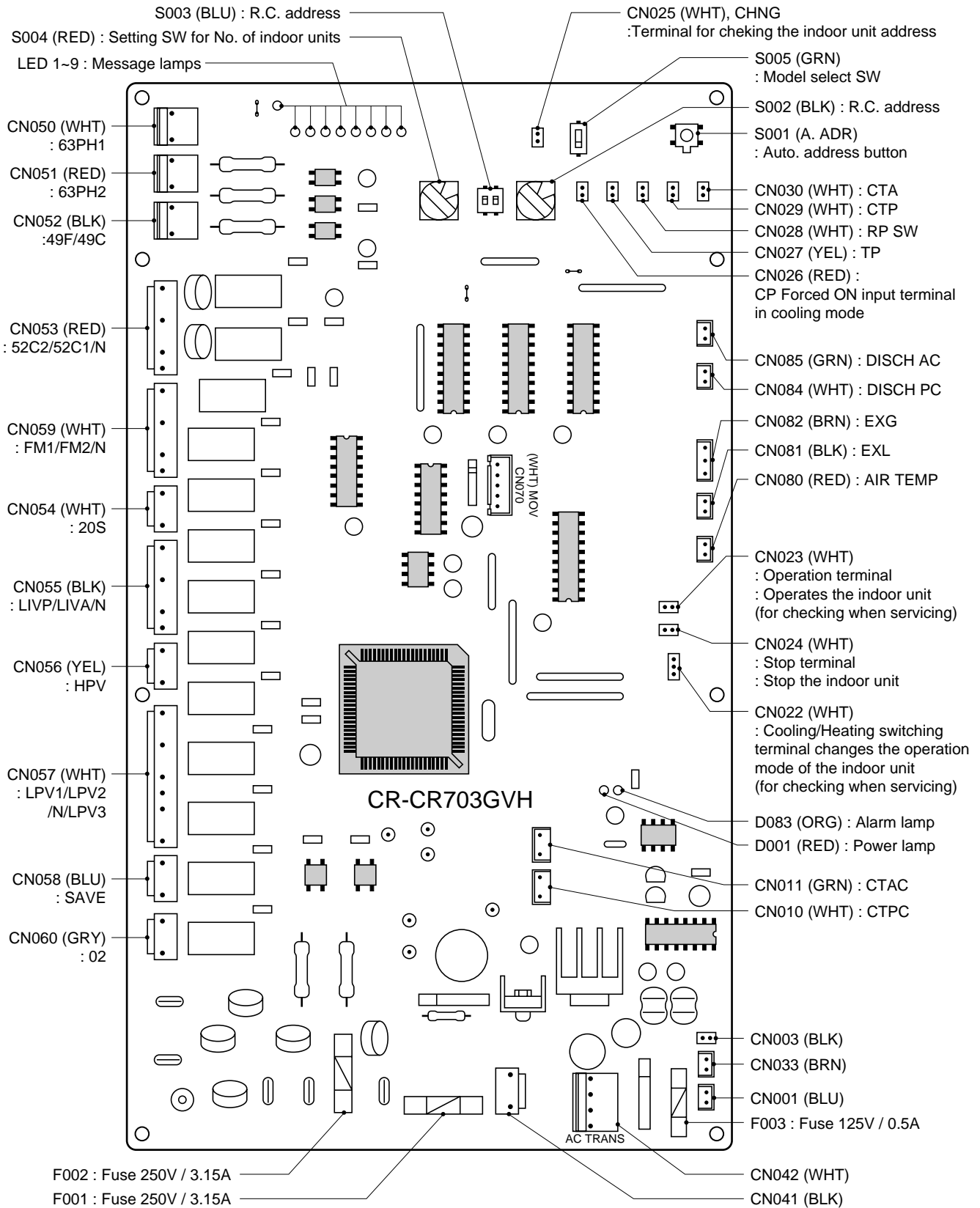

1209_THS_1

6. Check of Density Limit

Important

The room in which the air conditioner is to be installed requires a design that in the event of refrigerant gas leaking out, its density will not exceed a set limit.

The refrigerant R-407C which is used in the air conditioner is safe, without the toxicity or combustibility of ammonia, and is not restricted by laws to be imposed which protect the ozone layer. However, since it contains more than air, it poses the risk of suffocation if its density should rise excessively. Suffocation from leakage of R-407C is almost non-existent. With the recent increase in the number of high density buildings, however, the installation of multi air conditioner systems is on the increase because of the need for effective use of floor space, individual control, energy conservation by curtailing heat and carrying power etc.

Most importantly, the multi air conditioner system is able to replenish a large amount of refrigerant compared with conventional individual air conditioners. If a single unit of the multi air conditioner system is to be installed in a small room, select a suitable model and installation procedure so that if the refrigerant accidentally leaks out, its density does not reach the limit (and in the event of an emergency, measures can be made before injury can occur). In a room where the density may exceed the limit, create an opening with adjacent rooms, or install mechanical ventilation combined with a gas leak detection device. The density is as given below.

Total amount of refrigerant (kg)

Min. volume of the indoor unit installed room (m³)

≤ Density limit (kg/m³)

The density limit of R-407C which is used in multi air conditioners is 0.3 kg/m³.

NOTE 1 : If there are 2 or more refrigerating systems in a single refrigerating device, the amount of refrigerant should be as charged in each independent device.

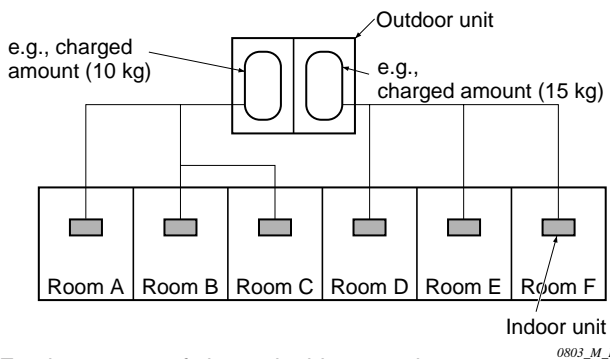

For the amount of charge in this example:

The possible amount of leaked refrigerant gas in rooms A, B and C is 10 kg.

The possible amount of leaked refrigerant gas in rooms D, E and F is 15 kg.

NOTE 2 : The standards for minimum room volume are as follows.

(1) No partition (shaded portion)

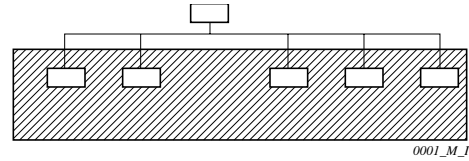

(2) When there is an effective opening with the adjacent room for ventilation of leaking refrigerant gas (opening without a door, or an opening 0.15% or larger than the respective floor spaces at the top or bottom of the door).

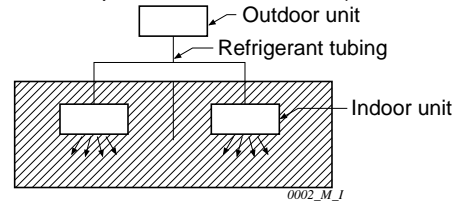

(3) If an indoor unit is installed in each partitioned room and the refrigerant tubing is interconnected, the smallest room of course becomes the object. But when a mechanical ventilation is installed interlocked with a gas leakage detector in the smallest room where the density limit is exceeded, the volume of the next smallest room becomes the object.

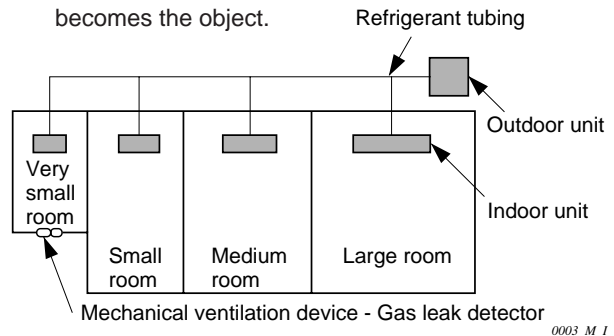

NOTE 3 : The minimum indoor floor space compared with the amount of refrigerant is roughly as follows. (When the ceiling is 2.7 m high)

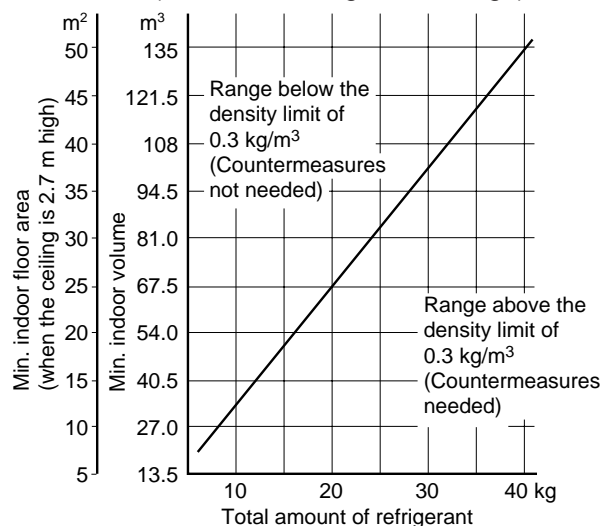

7. Cautions for New Refrigerant R407C

1 Care regarding piping

1-1. There is no need to change piping and tube wall thickness. Use refrigerant pipes of the same wall thickness as R22.

Type		O						1/2 H, H	
Copper tube	Outer diameter	ø6.35	ø9.52	ø12.7	ø15.88	ø19.05	ø22.2	ø25.4	ø28.58
	Wall thickness	0.8	0.8	0.8	1.0	1.0	1.2	1.0	1.0

* C1220 type with JIS H 3300 designation (Copper Pipe and Copper Alloy Seamless Pipe)

1-2. Prevent impurities including water, dust and oxide from coming into the pipe.

Impurities can cause R407C refrigerant deterioration and compressor defects.

Due to the different features of the refrigerant and refrigerating machine oil, the prevention of water and other impurities becomes more important than ever.

2 Make sure to refill the refrigerant in liquid form.

2-1. Since R407C is a non-azeotrope, refilling the refrigerant in gas form can lower performance and cause defects of the unit.

2-2. Since refrigerant composition changes and performance decreases when gas leaks, collect the remaining refrigerant and refill the required total amount of new refrigerant after fixing the leak.

3 Different tools

3-1. Tools specs have been changed due to the features of R407C.

Some of the R22 tools cannot be used.

Product name	New tools	R22 tools compatible with R407C	Remarks
Gauge manifold	Yes	No	Types of refrigerant and refrigerating machine oil, and pressure gauge are different.
Charge hose	Yes	No	To resist pressure and oil, material has been changed.
Vacuum pump	Yes	Yes	Use a conventional vacuum pump if it is equipped with a check valve. If it has no check valve, purchase and attach a vacuum pump adaptor.
Leak detector	Yes	No	Leak detectors for CFC and HCFC which react to chlorine do not function because R407C contains no chlorine. Leak detector for R407C can be used for HFC134a.
Flaring oil	Yes	No	Mineral oil (for example, suniso oil) can be used as R22 oil. Use synthetic fluid (for example, ether oil) as R407C oil.

* Using both R22 tools and new tools together can cause defects.

3-2. Use a R407C exclusive cylinder only.

Gauge manifold

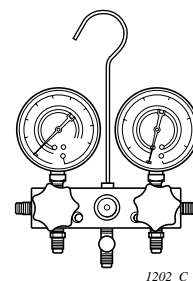

1202_C_1

Vacuum pump

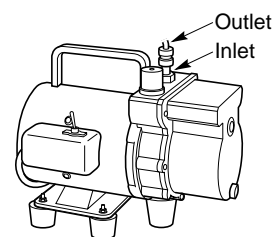

1203_C_1

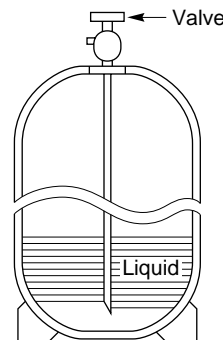

1171_M_1

Single-outlet valve

(with siphon tube)

Liquid refrigerant can be refilled standing it up straight.

SM830063

7. Cautions for New Refrigerant R407C

New refrigerant R407C cannot be used for existing models.

1. Compressor specs are different.

When refilling the R22 compressor with R407C, durability will significantly decrease since some of the materials used for compressor parts are different.

2. Existing piping cannot be used.

Completely cleaning out residual refrigerating machine oil is impossible, even by flushing.

3. Refrigerating machine oil differs.

Since R22 refrigerating machine oil is mineral oil, it does not dissolve in R407C. Therefore, refrigerating machine oil discharged from the compressor can cause compressor damage.

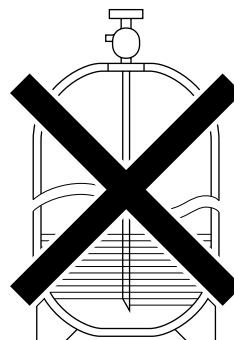

1172_M_1

R407C

R22 refrigerating machine oil	Mineral oil (suniso oil)
R407C refrigerating machine oil	Synthetic fluid (ether oil)

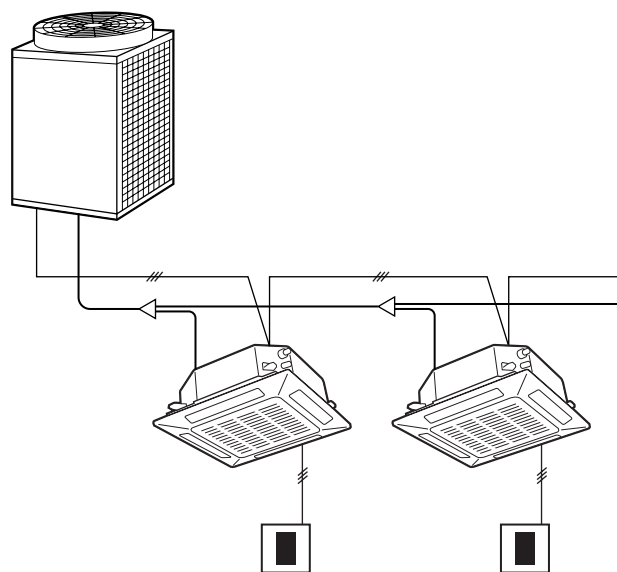

1173_X_S



9. Operation Procedure for Replacing the Compressor

9-1. Preperation

Operate correctly according to the procedure below.

- (1) Turn off the indoor and outdoor unit switches. Turn on the indoor switch again, and after 1 minute, turn off.
(This is to completely open the electronic refrigerant control valve of the indoor unit.)
- (2) Collect all the refrigerant from the service valve service port with the refrigerant collection device. From the fully open state, turn each spindle 1 / 2 to the right.

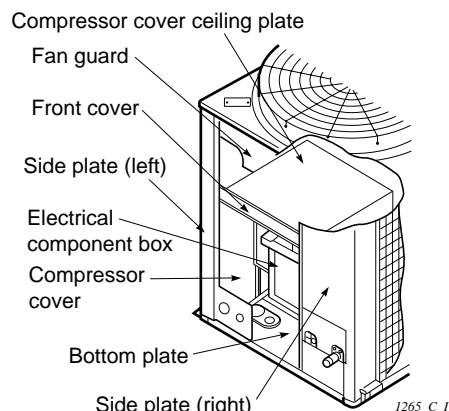

Fig. 1

9-2. Removal

- (1) Remove the fan guard shown in Fig. 1 (4 screws).
- (2) Remove the cover in front of the compressor cover ceiling plate (2 screws).
- (3) Remove the compressor cover ceiling plate (2 screws). Lift up the left side of the ceiling plate and with the ceiling plate tilted, pull it out.
- (4) Remove the electrical units and control lines from the terminal plates.
- (5) Disconnect the connector connected to the outdoor unit PCB from inside the unit. (Solenoid, thermostat, fan motor, crank case heater, etc.)
- (6) Remove the electrical component box (4 screws).
- (7) Remove the screws holding the compressor cover main unit and shift it to the rear.
(3 locations at the bottom plate and 2 locations at the left / right side plates)
- (8) Remove the noise absorbing material packed around the compressor.
- (9) Remove the compressor terminal section cap and disconnect the power terminals and internal terminals.
- (10) Remove the crank case heater.
- (11) Remove the 2 bolts (front side) shown in Fig. 2 and the 1 nut with washer (rear side).
- (12) Prepare to remove the welded section in Fig. 3.
 - Protect the sensor section, surrounding metal plates, rubber pieces, leads, clampers, etc.
- (13) Disconnect the welded section shown in Fig. 3.
 - Power control compressor — 5 locations
 - Standard compressor — 3 locations
- (14) Pull the compressor forward.
(Be careful not to damage the bottom plate.)

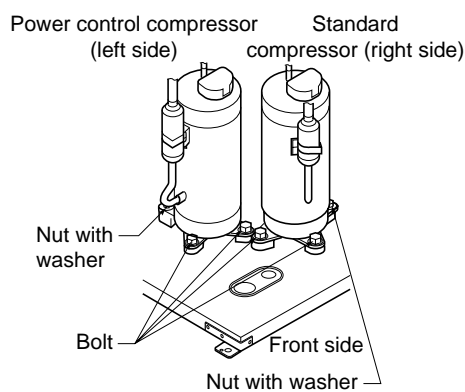

Fig. 2

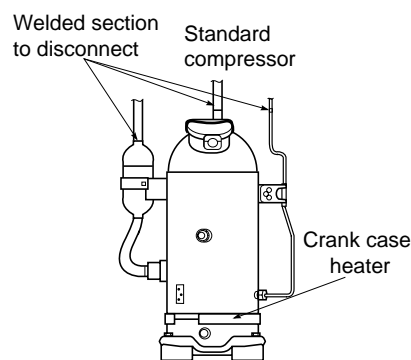
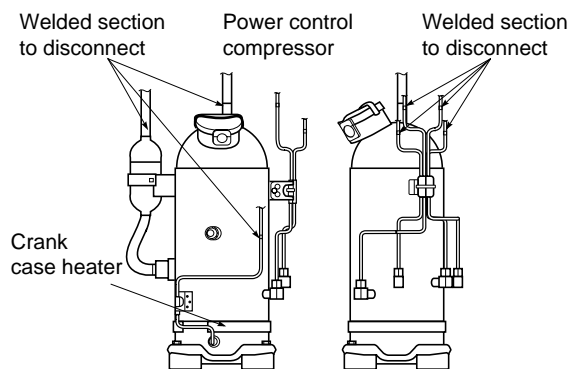
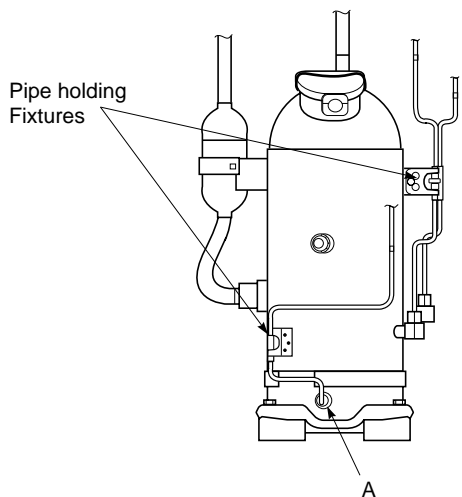

Fig. 3

9. Operation Procedure for Replacing the Compressor

9-3. Installation

- (1) Be sure to avoid air and moisture in the refrigerant system. Remove the rubber plug and suction pipe cap from the new compressor.



1243_C_1

- (2) Install the crank case heater on the compressor.
- (3) Put the compressor rubber cushion on the prescribed position of the bottom plate.
- (4) Set the compressor on the unit. The left side is the power control compressor. (Install in the same state as the original state.)
- (5) Form the pipes and insert in the brazing location.
- (6) Braze the each portion. At this time, replace air in the refrigerant system to nitrogen.
- (7) Raise the air-tight test pressure to 3.3 MPa (33 kg/cm²G) with nitrogen and check that there are no leaks.
- (8) Install the removed parts and also electrical component box in its original state.
- (9) After completing the air-tight test, evacuate the indoor/outdoor units and pipes. Target vacuum condition is -755 mmHg.
- (10) After evacuation, charge the refrigerant R407C.
Charge the sum of the "factory refrigerant amount" and "additional charging refrigerant amount" which are mentioned on the nameplate and installation instructions.
 - Refrigerant charging should be performed in the liquid state.
 - Never use refrigerant other than R407C.

10. Malfunction due to Noise

Since communication control is performed by pulse signals, the unit is susceptible to external noise. The circuitry has been designed in consideration of external noise and troubles should not occur in ordinary use. However, depending on the installation conditions, there may be trouble caused by the noise.

High-frequency noise, etc. is superimposed on the signal wire and the signal pulses come abnormal, resulting in malfunction.

Location easily subject to noise	Symptom	Remedy
1. Area with strong radio waves in the vicinity of a broadcasting station. 2. In the vicinity of a radio station. 3. Location near a high-frequency sewing machine or an arc welding machine.	1. Stops during operation. 2. Liquid crystal display flickers.	Treat the signal wire so that it will not be influenced by noise. ↓ • Place the signal/wire away from the generating source. • Adopt the shielding wire.

11. Checking procedure for PCB (Printed Circuit Board)

The indoor PCB (Printed Circuit Board) have functions to check the signal transmission and reception of the serial circuit and to check the microcomputer operation. (Self-diagnosis function)

● Precautions required when checking

- After turning off the power to the indoor unit, remove the inter-unit control wiring (U1-U2) and create a short-circuit between U1 and U2.
- Short the CHECK PIN on the PCB (Printed Circuit Board) of the indoor unit and turn on the power.

11-1. Checking the serial circuit

Indoor PCB (Printed Circuit Board) : A lighted LED indicates normal. A blinking LED indicates abnormal.

Outdoor PCB (Printed Circuit Board) : Blinking LEDs (D001 and D083) indicate normal. If one of the LEDs (D001 and D083) goes off, it indicates abnormal.

11-2. Checking microcomputer operation

When the microcomputer works normally, the relays are switched in sequence as below.

Indoor PCB (Printed Circuit Board)

	Output	ON time
Operation order	Indoor fan Very high fan speed (HH)	0.5 seconds
	Indoor fan High fan speed (H)	0.5 seconds
	Indoor fan Low fan speed (L)	0.5 seconds
	Indoor fan Very low fan speed (LL)	0.5 seconds
	Drain pump	0.5 seconds
	Operation signal	0.5 seconds
	Alarm LED	0.5 seconds
	Electronic expansion valve A	0.5 seconds
	Electronic expansion valve B	0.5 seconds
	Electronic expansion valve \bar{A}	0.5 seconds
Electronic expansion valve \bar{B}	0.5 seconds	

12. Check Pins

12-1. Indoor PCB (Printed Circuit Board)

If the check pins on the indoor PCB (Printed Circuit Board) are short-circuited, output operation for each unit can be performed independently.

- If the FORCED OPR pins (CN5, white) are short-circuited, the indoor unit enters the operation mode listed in the table below.
- Without connecting the remote controller, the indoor unit can be operated independently.

	Output	Operation
1	Relay 2X	Indoor fan motor operates in high fan speed mode.
2	Relay RY2	Dew proof heater and drain pump operate.
3	Electronic refrigerant control valve	Fully open (480 steps)

12-2. Outdoor PCB (Printed Circuit Board)

If the check pins on the outdoor PCB (Printed Circuit Board) are short-circuited, output operation for each section can be performed independently.

- If the CHECK pins (CN26, red) are short-circuited after turning off the power to the outdoor unit, and the power is turned on again, output is executed for 3 seconds for each section. After the output is completed, the outdoor unit enters the stop mode.

	Output	Operation
1	LEDs 1 to 8	Lit
2	An LED distant from LEDs 1 to 8	Lit
3	Alarm LED	Lit
4	Relay RY10	Save valve (SAVE) ON
5	Relay RY6	High pressure valve (HPV) ON
6	Relay RY7	Low pressure valve 1 (LPV1) ON
7	Relay RY8	Low pressure valve 2 (LPV2) ON
8	Relay RY9	Low pressure valve 3 (LPV3) ON
9	Relay RY3	4-way valve (2OS) ON
10	Relay RY4	Liquid valve (Power control compressor) ON
11	Relay RY5	Liquid valve (Standard compressor) ON

- If the double speed pins (TEST PIN) (CN27, yellow) on the outdoor PCB (Printed Circuit Board) are short-circuited after the above operation, the outdoor fan and compressor operate in the cooling mode. However, if the protection device is activated, they will enter the alarm operation mode.

NOTE

If you do not want to activate the compressor, disconnect the compressor wiring from the magnetic contactor.

13. Double Speed of Time for the Timer

- If the double speed pins (TEST PIN) (CN27, yellow) on the outdoor PCB (Printed Circuit Board) are short-circuited, the time for each delay timer on the outdoor side is shortened.

NOTE

If the outdoor unit is turned on and off repeatedly in the double speed mode, the compressor will be damaged. So operates the double speed mode with care. (Normally set this mode to OFF.)

Contents

4. Electrical Data

1. Outdoor Unit	IV - 2
(1) SPW-CR363GVH8, SPW-CR483GVH8	IV - 2
(2) SPW-CR363GV8, SPW-CR483GV8	IV - 4
(3) SPW-CR703GVH8, SPW-CR903GVH8	IV - 6
(4) SPW-CR703GV8, SPW-CR903GV8	IV - 8
2. Indoor Unit	IV -10
(1) SPW-XR123GH56, SPW-XR183GH56, SPW-XR253GH56, SPW-XR363GH56, SPW-XR483GH56	IV - 10
(2) SPW-SR93GH56, SPW-SR123GH56, SPW-SR183GH56, SPW-SR253GH56	IV - 12
(3) SPW-ASR93GH56, SPW-ASR123GH56	IV - 14
(4) SPW-KR93GH56, SPW-KR123GH56, SPW-KR183GH56	IV - 16
(5) SPW-TR183GH56, SPW-TR253GH56, SPW-TR363GH56, SPW-TR483GH56	IV - 18
(6)-1 SPW-UR93GH56, SPW-UR123GH56, SPW-UR183GH56, SPW-UR253GH56	IV - 20
(6)-2 SPW-UR363GH56, SPW-UR483GH56	IV - 22
(7)-1 SPW-DR253GH56	IV - 24
(7)-2 SPW-DR363GH56	IV - 26
(7)-3 SPW-DR483GH56	IV - 28
(8) SPW-FR93GH56, SPW-FR123GH56, SPW-FR183GH56, SPW-FR253GH56	IV - 30
(9) SPW-FMR93GH56, SPW-FMR123GH56, SPW-FMR183GH56, SPW-FMR253GH56	IV - 32
(10) SPW-SLR93GH56, SPW-SLR123GH56, SPW-SLR183GH56, SPW-SLR253GH56	IV - 34

1. Outdoor Unit

(1) SPW-CR363GVH8, SPW-CR483GVH8

• Electric Wiring Diagram

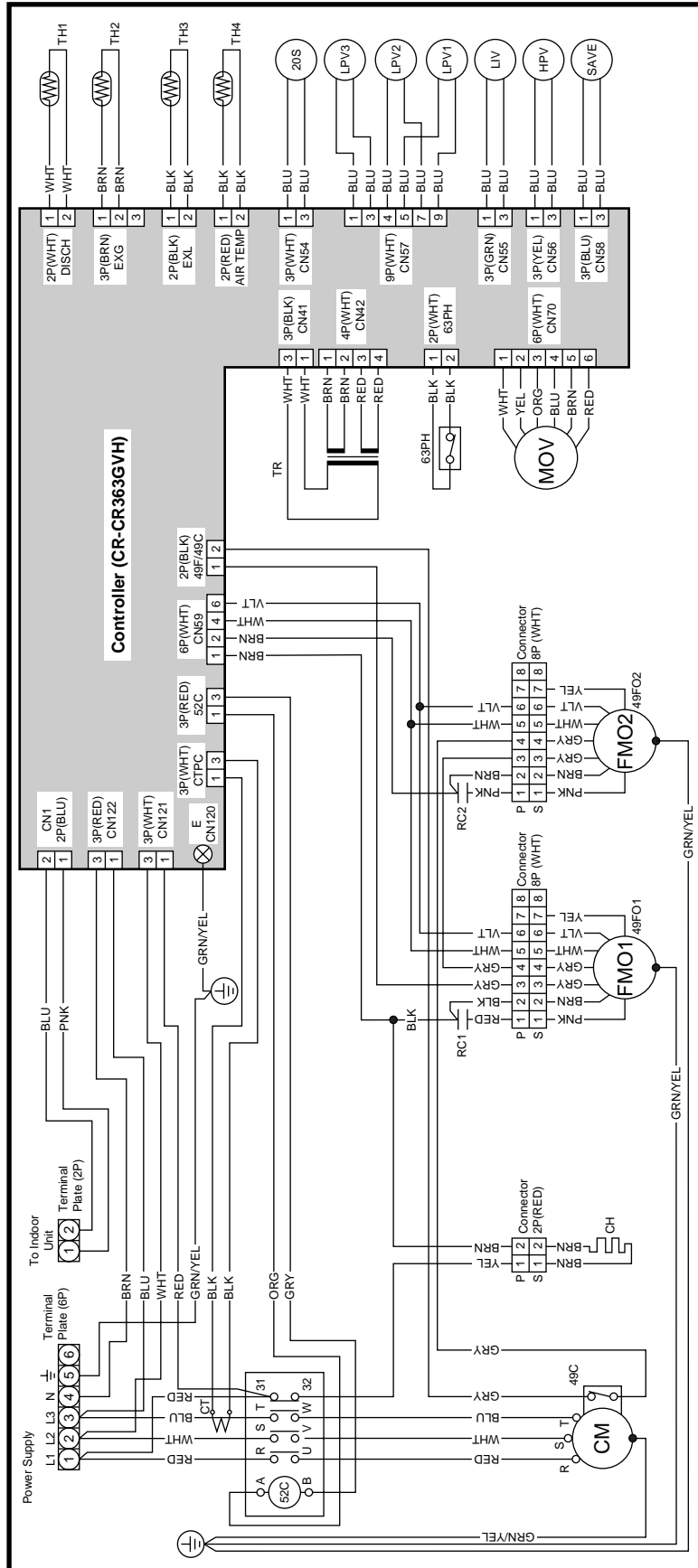

(W) 854-2-5268-760-00-0 (CR363GVH8)

1. Outdoor Unit

(1) SPW-CR363GVH8, SPW-CR483GVH8

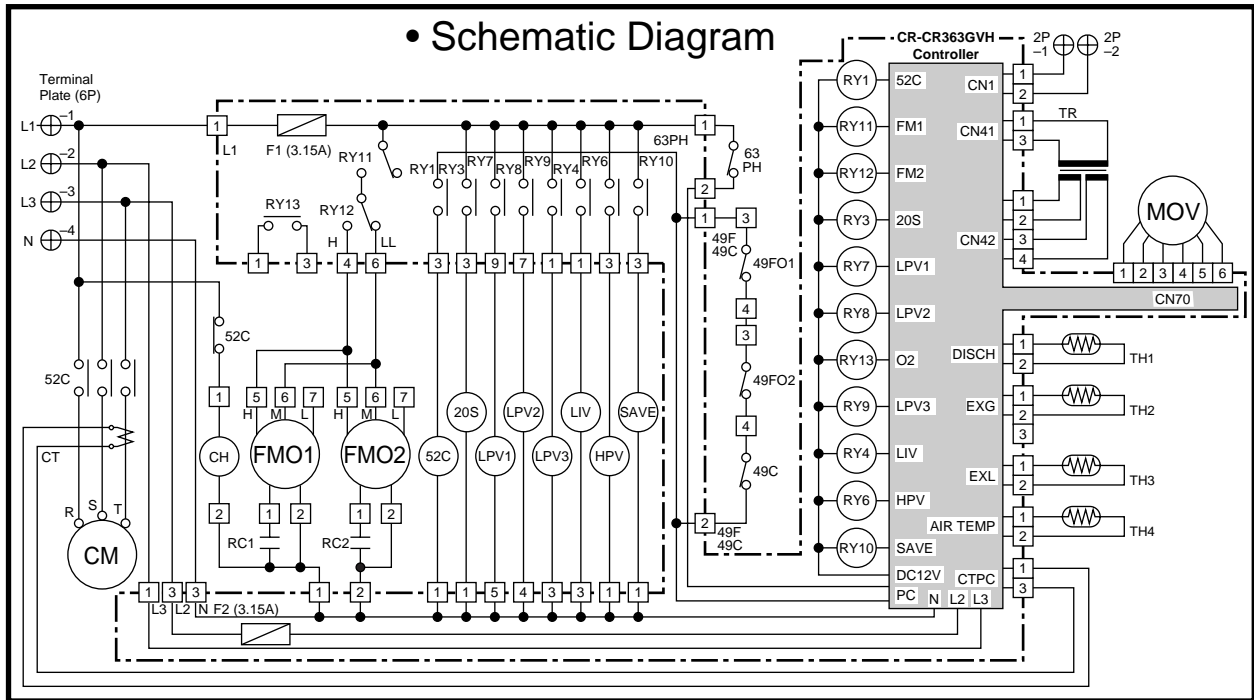

Symbols	Description	Symbols	Description
CM	Compressor Motor	CT	Current Transmitter
FMO1, 2	Outdoor Fan Motor	63PH	High Pressure Switch
CH	Crank Case Heater	F1, 2	Fuse
52C	Compressor Motor Magnetic Contactor	TH1	Thermistor (Discharge PC)
49C	Compressor Motor Thermal Protector	TH2	Thermistor (Coil Gas Sensor)
49FO1, 2	Fan Motor Thermal Protector	TH3	Thermistor (Coil Liquid Sensor)
RC1, 2	Running Capacitor	TH4	Thermistor (Air Suction Temp)
20S	Four Way Valve	TR	Power Transformer
SAVE	Save Valve	RY1, 3, 4, 6-13	Auxiliary Relay
HPV	High Pressure Valve	□	Connector
LPV1-3	Low Pressure Valve	⊕	Terminal
LIV	LI INJ.Valve	⊗	Terminal
MOV	Motor Operated Valve	CR-CR363GVH	Outdoor Controller

© 854-2-5268-760-00-0 (CR363GVH8)



1. Outdoor Unit

(2) SPW-CR363GV8, SPW-CR483GV8

• Electric Wiring Diagram

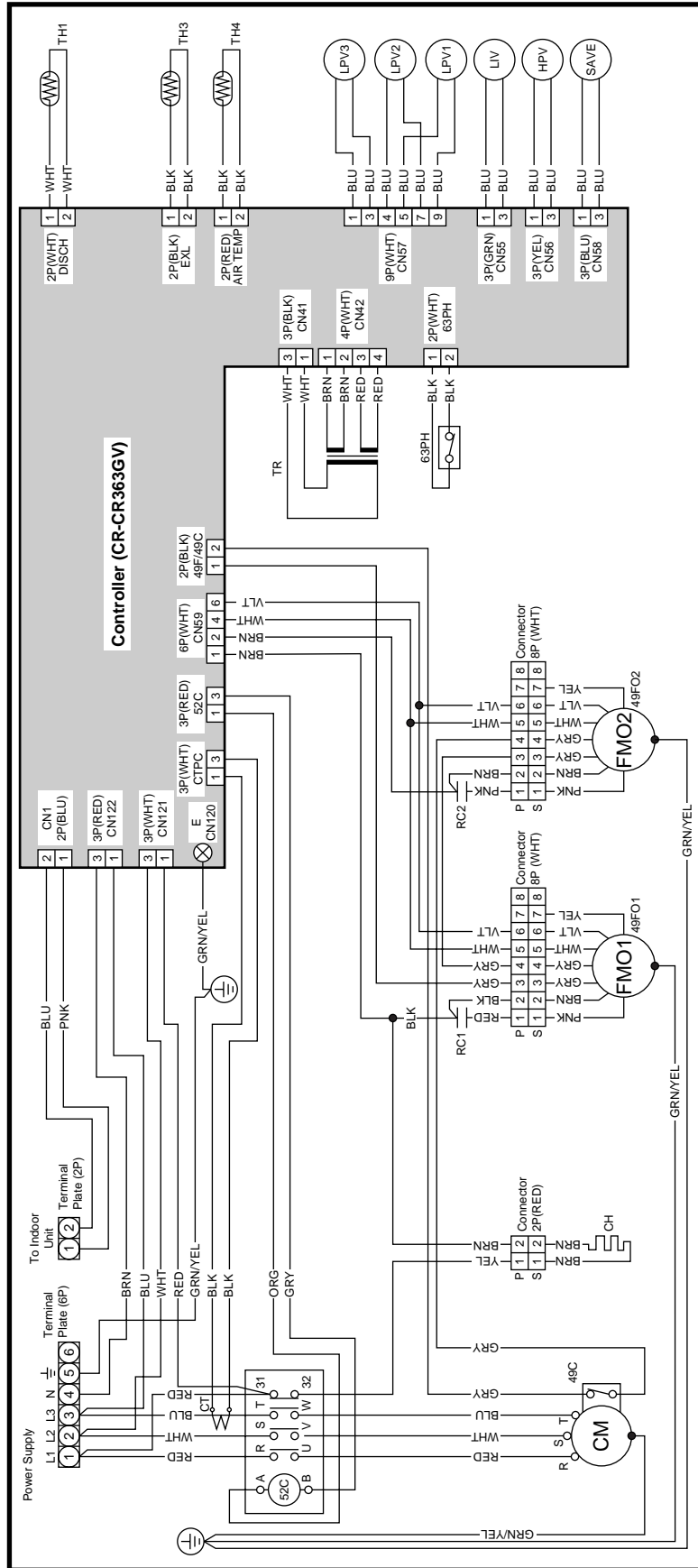

Ⓜ 854-2-5268-761-00-0 (CR363GV8)

1. Outdoor Unit

(2) SPW-CR363GV8, SPW-CR483GV8

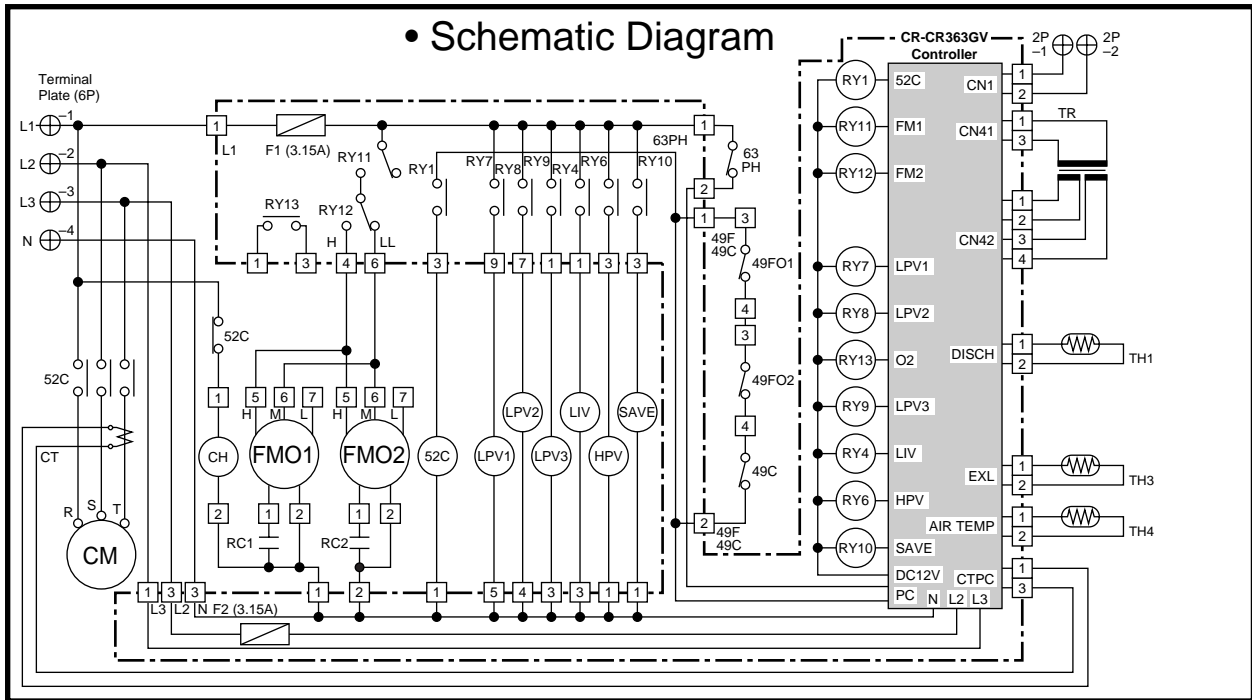

Symbols	Description	Symbols	Description
CM	Compressor Motor	F1, 2	Fuse
FMO1, 2	Outdoor Fan Motor	TH1	Thermistor (Discharge PC)
CH	Crank Case Heater	TH3	Thermistor (Coil Liquid Sensor)
52C	Compressor Motor Magnetic Contactor	TH4	Thermistor (Air Suction Temp)
49C	Compressor Motor Thermal Protector	TR	Power Transformer
49FO1, 2	Fan Motor Thermal Protector	RY1, 4, 6-13	Auxiliary Relay
RC1, 2	Running Capacitor	□	Connector
SAVE	Save Valve	⊕	Terminal
HPV	High Pressure Valve	⊗	Terminal
LPV1-3	Low Pressure Valve	CR-CR363GV	Outdoor Controller
LIV	LI INJ.Valve		
CT	Current Transmitter		
63PH	High Pressure Switch		

© 854-2-5268-761-00-0 (CR363GV8)

1. Outdoor Unit

(3) SPW-CR703GVH8, SPW-CR903GVH8

• Electric Wiring Diagram

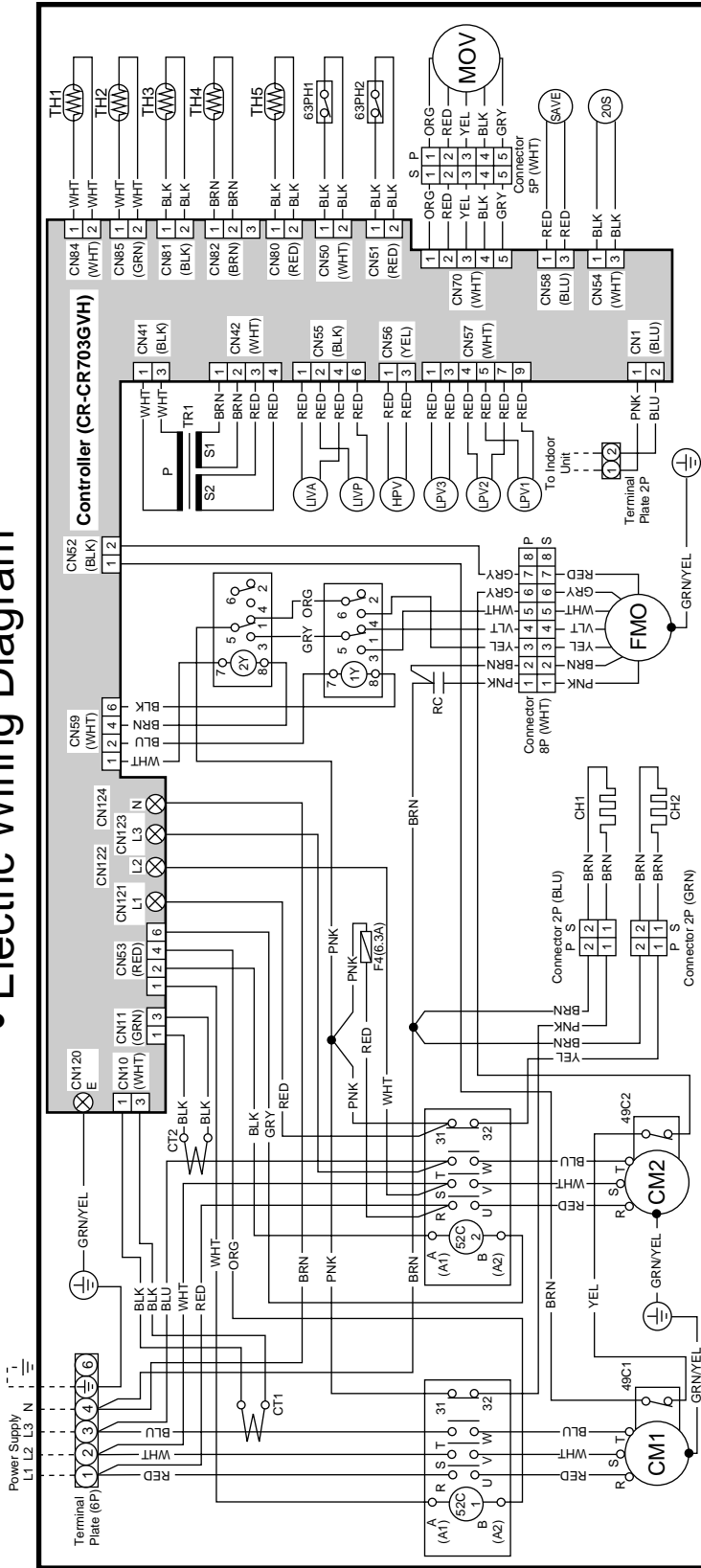

④ 854-2-5268-643-00-1 (CR703GVH8, CR903GVH8)

1. Outdoor Unit

(3) SPW-CR703GVH8, SPW-CR903GVH8

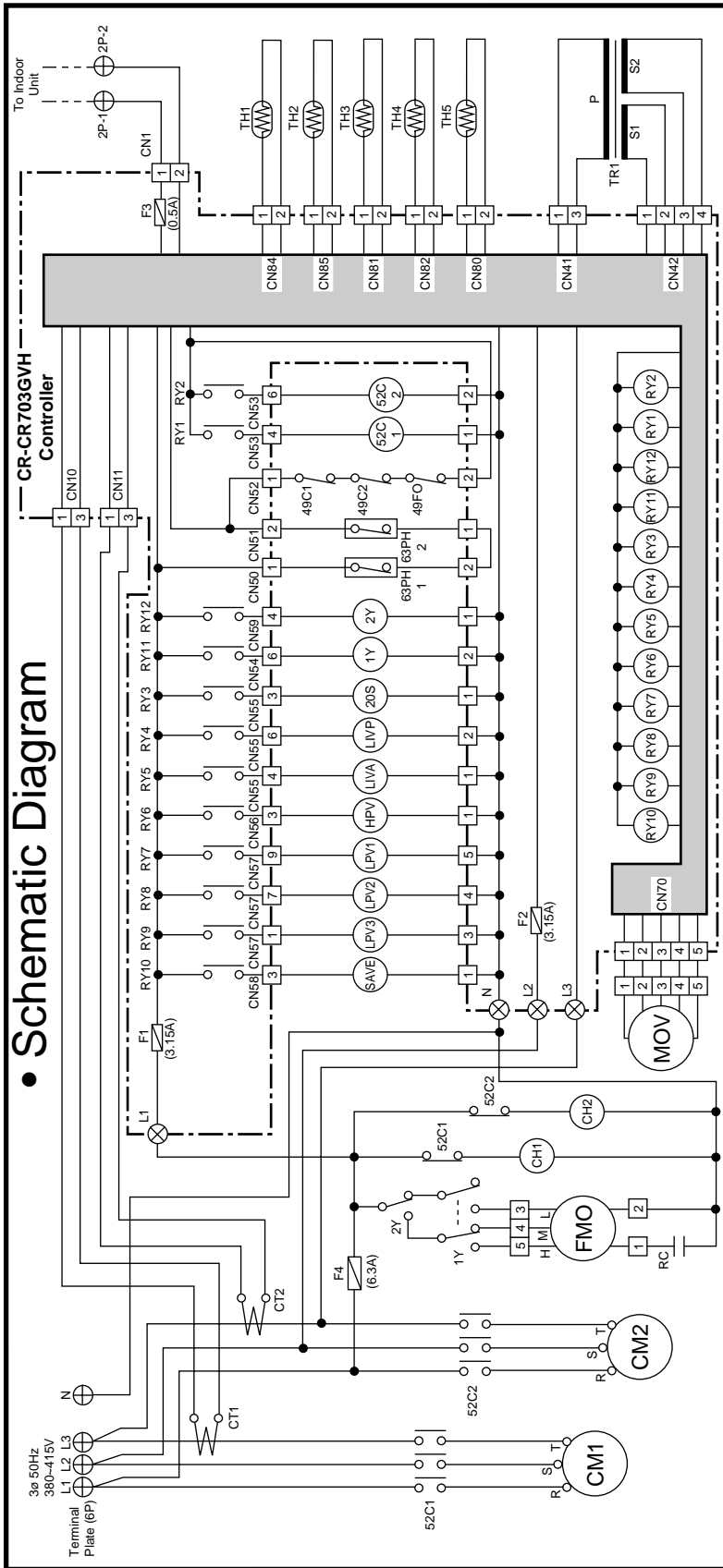

Symbols	Description	Symbols	Description
CM1,2	Compressor Motor	SAVE	Save Valve
FMO	Outdoor Fan Motor	MOV	Motor Operated Valve
CH1,2	Crank Case Heater	TH1	Thermistor (Discharge PC)
52C1,2	Compressor Motor Magnetic Contactor	TH2	Thermistor (Discharge AC)
RC	Running Capacitor	TH3	Thermistor (Coil Liquid Temp)
49C1,2	Compressor Motor Thermal Protector	TH4	Thermistor (Coil Gas Temp)
49FO	Fan Motor Thermal Protector	TH5	Thermistor (Air Suction Temp)
CT1,2	Current Transmitter	TR1	Power Transformer
63PH1,2	High Pressure Switch	F1,2,3,4	Fuse
20S	Four Way Valve	1Y,2Y,RY1-10	Auxiliary Relay
LIVP	LI INJ. Valve PC	CR	Connector
LIVA	LI INJ. Valve AC	□	Terminal
HPV	High Pressure Valve	⊕	Terminal
LPV1	Low Pressure Valve 1	⊗	Terminal
LPV2	Low Pressure Valve 2	CR-CR703GVH	Outdoor Controller
LPV3	Low Pressure Valve 3		

⑤ 854-2-5268-643-00-1 (CR703GVH8, CR903GVH8)



1. Outdoor Unit

(4) SPW-CR703GV8, SPW-CR903GV8

• Electric Wiring Diagram

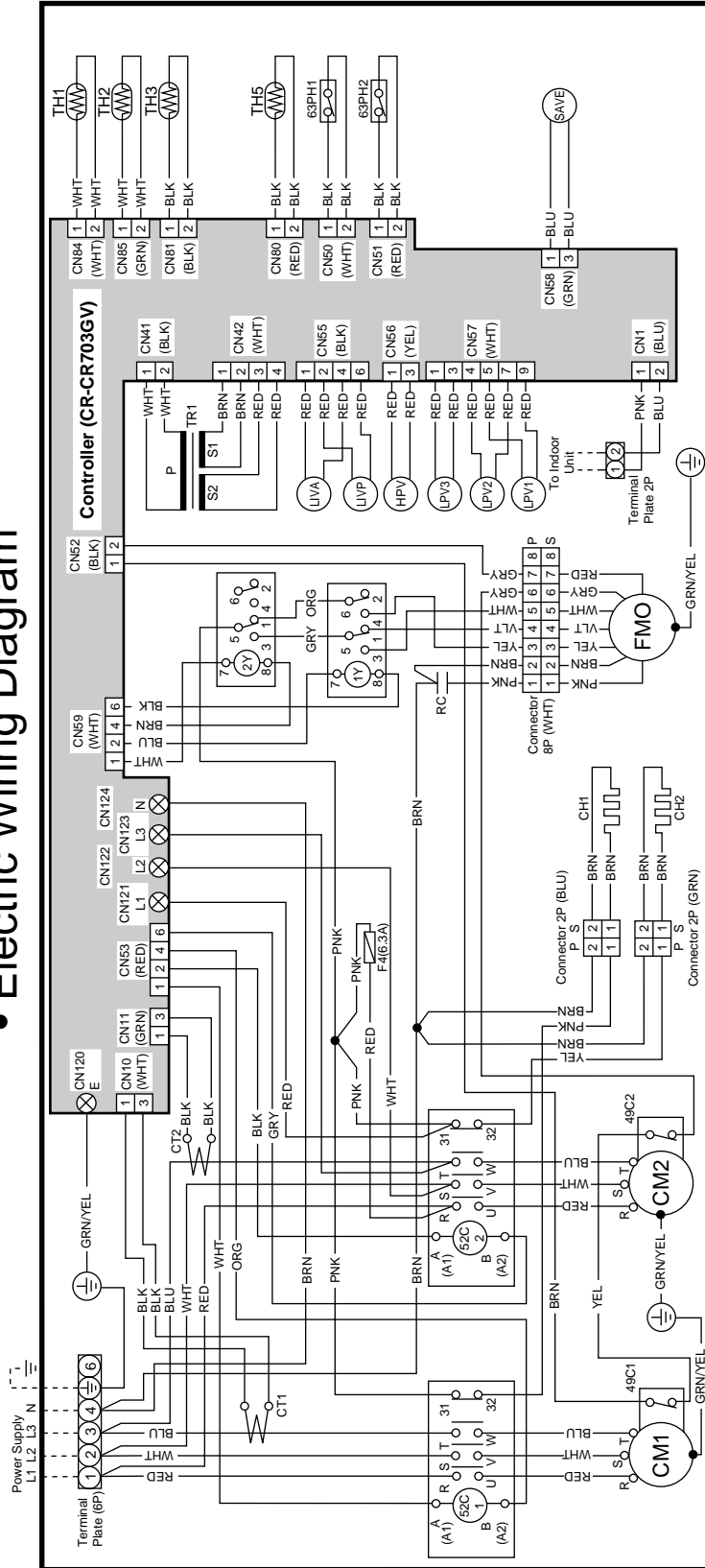

⑧ 854-2-5268-644-00-1 (CR703GV8, CR903GV8)

1. Outdoor Unit

(4) SPW-CR703GV8, SPW-CR903GV8

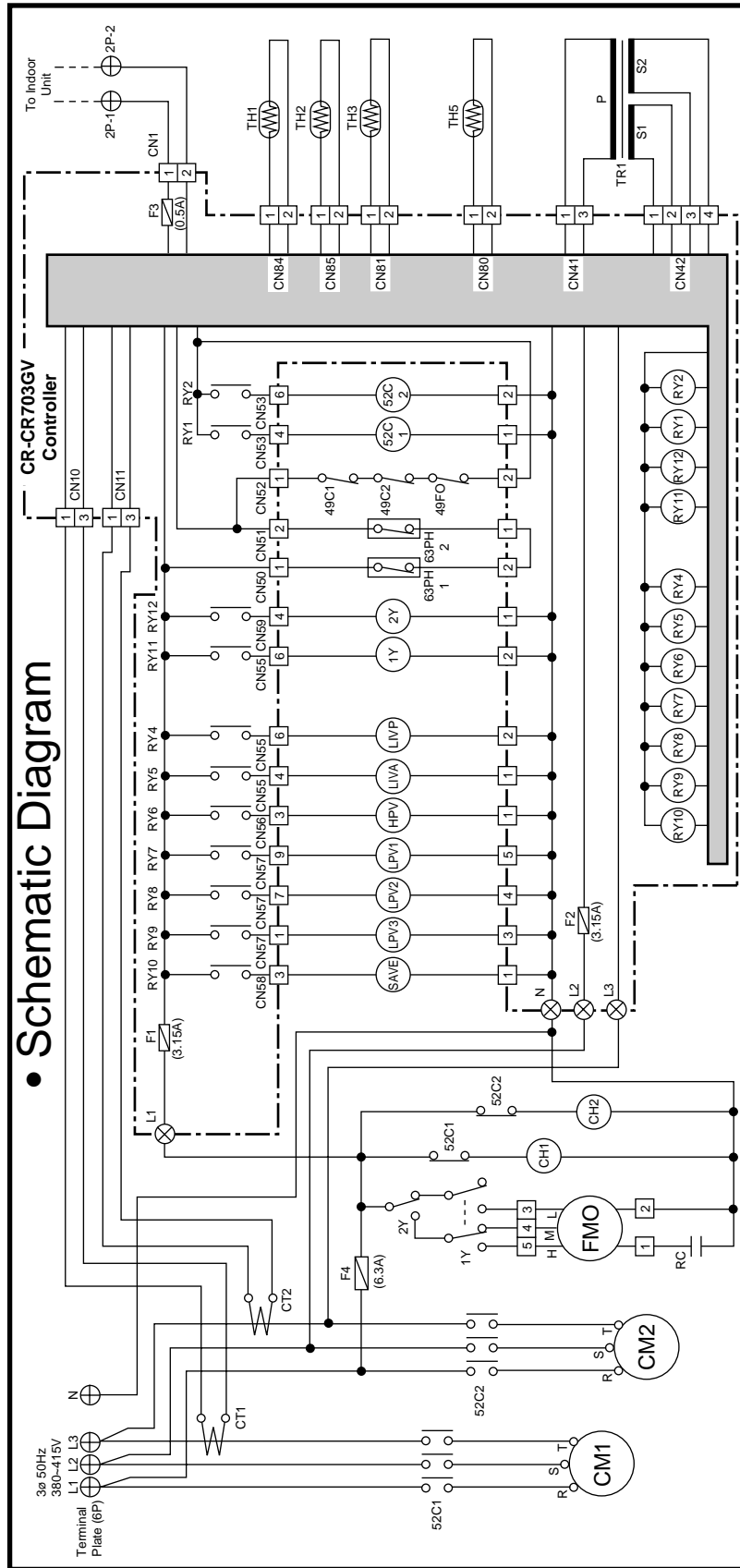

• Schematic Diagram

Symbols	Description	Symbols	Description
CM1,2	Compressor Motor	SAVE	Save Valve
FMO	Outdoor Fan Motor	TH1	Thermistor (Discharge PC)
CH1,2	Crank Case Heater	TH2	Thermistor (Discharge AC)
52C1,2	Compressor Motor Magnetic Contactor	TH3	Thermistor (Coil Liquid Temp)
RC	Running Capacitor	TH5	Thermistor (Air Suction Temp)
49C1,2	Compressor Motor Thermal Protector	TR1	Power Transformer
49FO	Fan Motor Thermal Protector	F1,2,3,4	Fuse
CT1,2	Current Transmitter	1Y,2Y,RY1-10	Auxiliary Relay
63PH1,2	High Pressure Switch	CR	Connector
L1VP	L1 INJ. Valve PC	□	Terminal
L1VA	L1 INJ. Valve AC	⊕	Terminal
HPV	High Pressure Valve	⊗	Terminal
LPV1	Low Pressure Valve 1	CR-CR703GV	Outdoor Controller
LPV2	Low Pressure Valve 2		
LPV3	Low Pressure Valve 3		

⑤ 854-2-5268-644-00-1 (CR703GV8, CR903GV8)



2. Indoor Unit

- (1) SPW-XR123GH56, SPW-XR183GH56, SPW-XR253GH56, SPW-XR363GH56, SPW-XR483GH56

• Electric Wiring Diagram

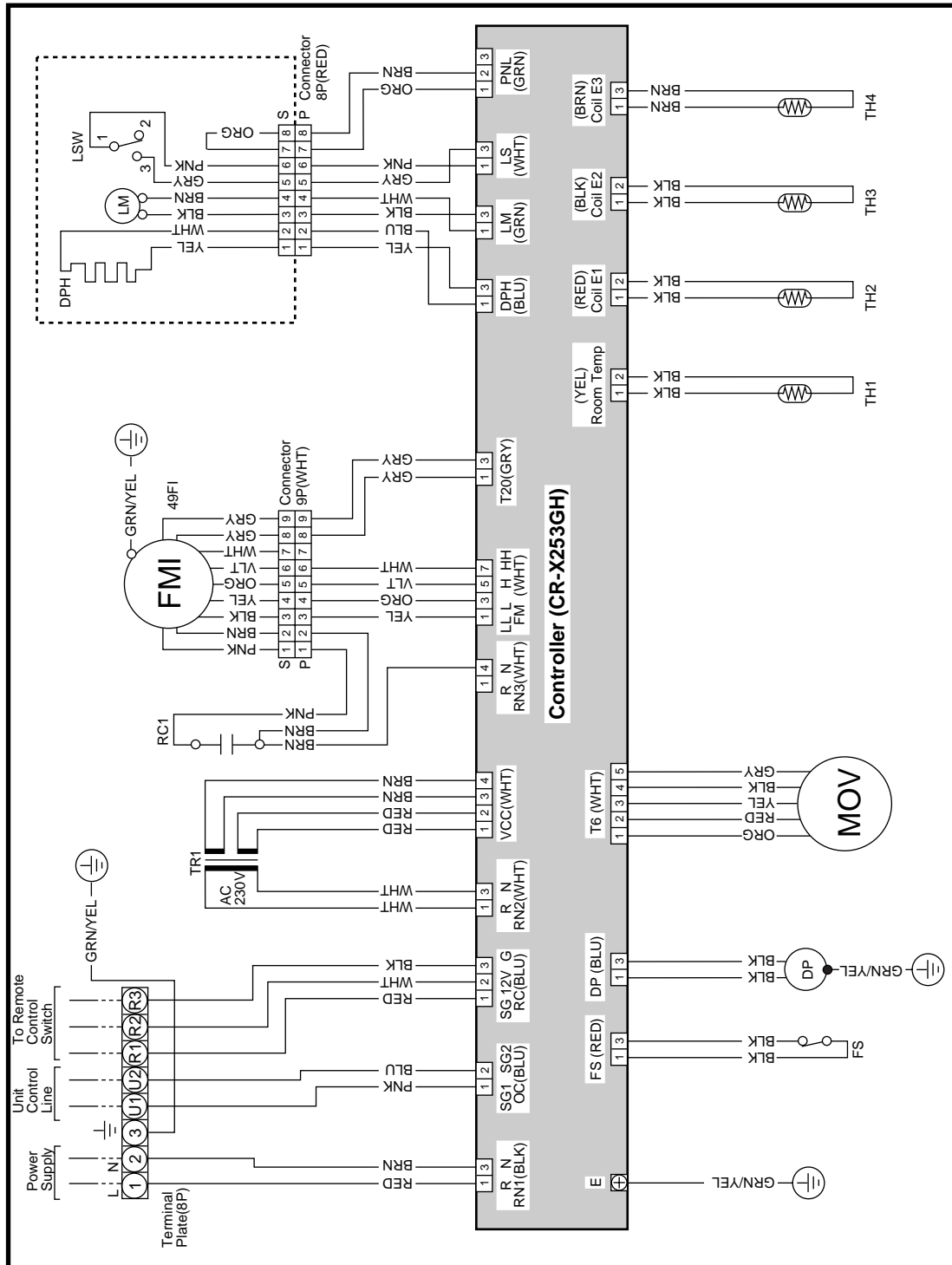

① 854-2-5268-470-00-3 (X)

2. Indoor Unit

- (1) SPW-XR123GH56, SPW-XR183GH56, SPW-XR253GH56, SPW-XR363GH56, SPW-XR483GH56

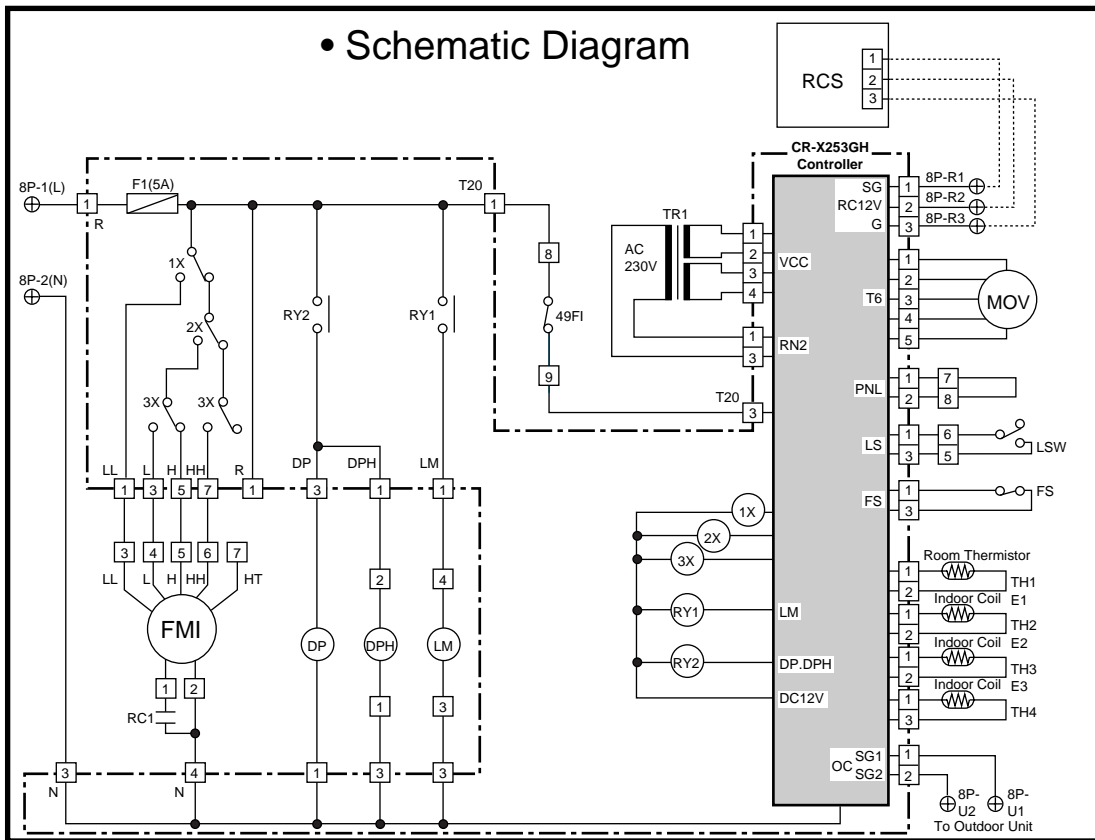

Symbols	Description	Symbols	Description
FMI	Indoor Fan Motor	TH3	Thermistor (Indoor Coil E2)
49FI	Indoor Motor Thermal Protector	TH4	Thermistor (Indoor Coil E3)
RC1	Running Capacitor	CR-X253GH	Indoor Controller
F1	Fuse	⊕	Terminal Plate
LM	Auto Louver Motor	□	Connector
TR1	Power Transformer	⊕	Terminal
1X-3X	Auxiliary Relay	DP	Drain Pump
RY1-RY2	Auxiliary Relay	DPH	Dew Proof Heater
MOV	Motor Operated Valve	LSW	Limit Switch
RCS	Remote Control Switch	FS	Float Switch
TH1	Room Thermistor		
TH2	Thermistor (Indoor Coil E1)		

© 854-2-5268-470-00-3 (X)

2. Indoor Unit

(2) SPW-SR93GH56, SPW-SR123GH56, SPW-SR183GH56, SPW-SR253GH56

• Electric Wiring Diagram

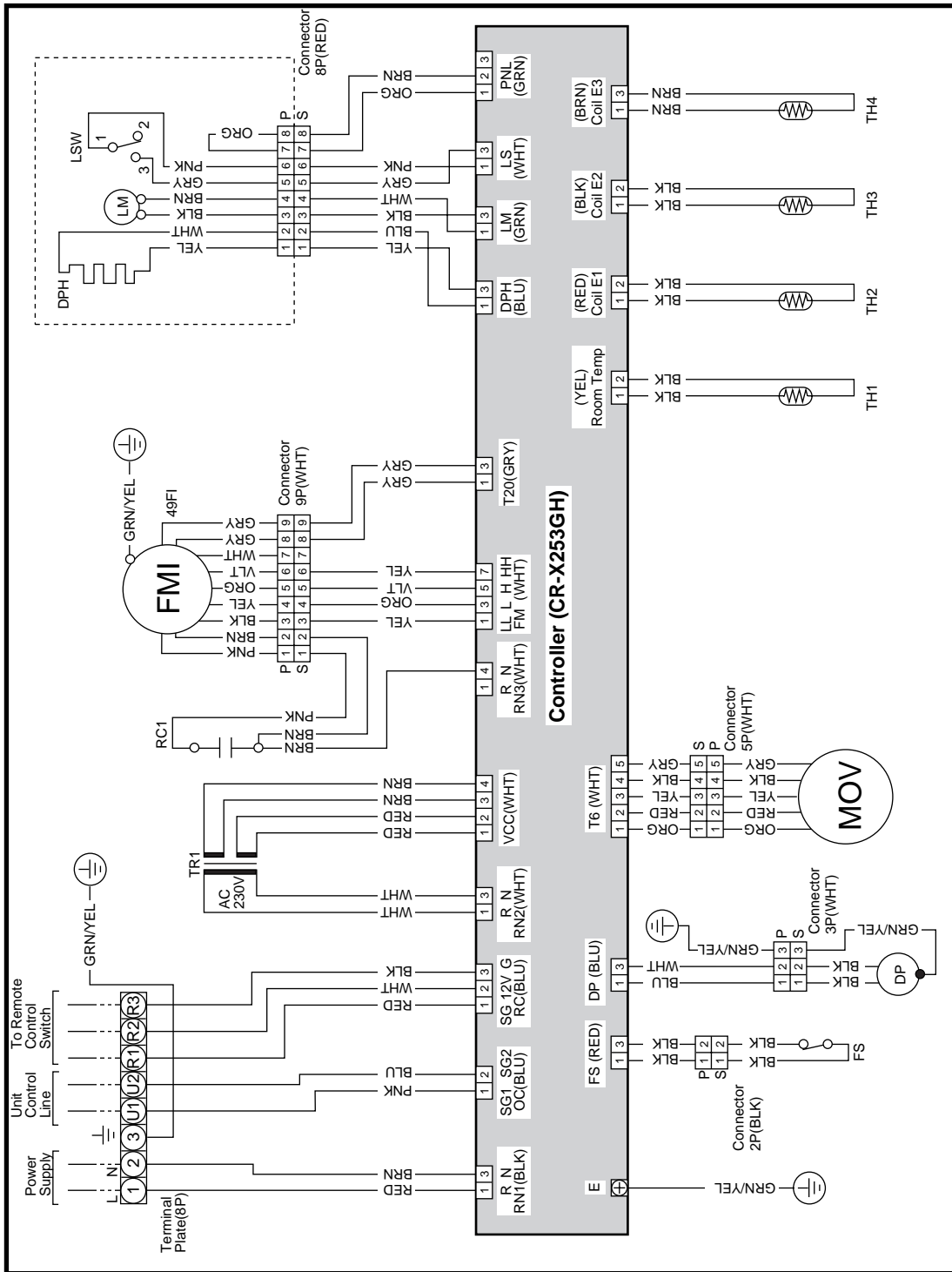

W 854-2-5268-413-00-2 (S)

2. Indoor Unit

(2) SPW-SR93GH56, SPW-SR123GH56, SPW-SR183GH56, SPW-SR253GH56

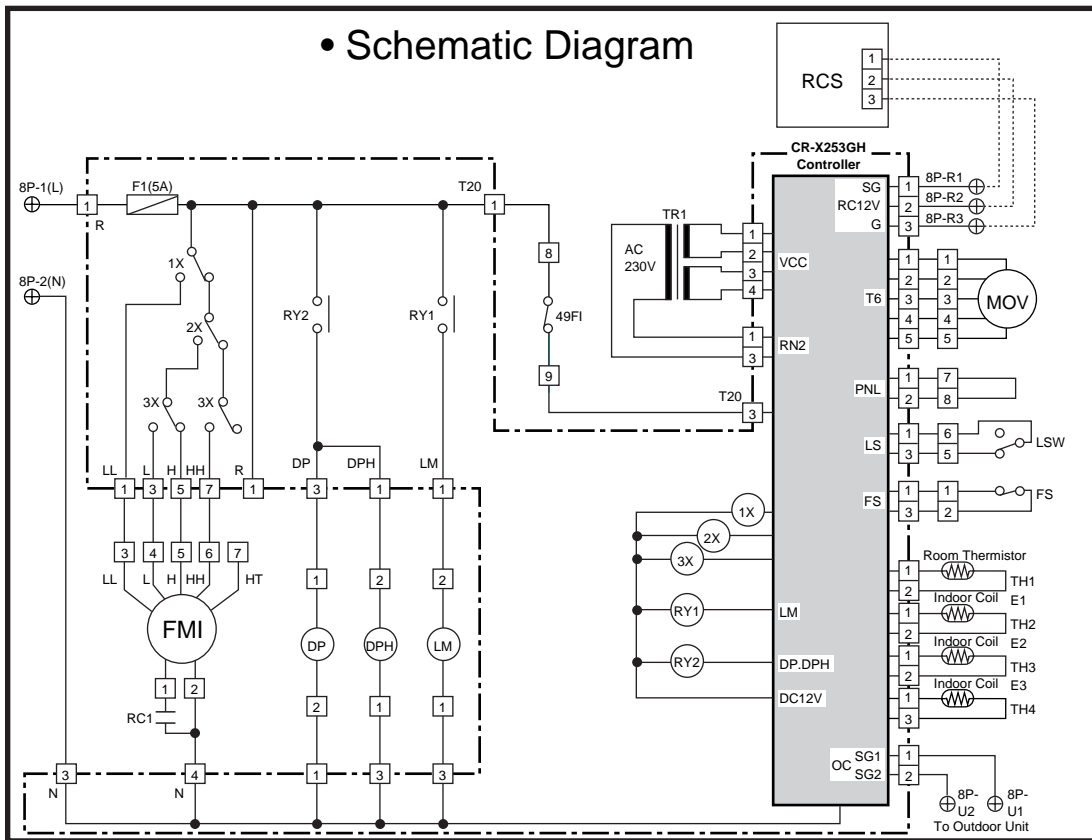

Symbols	Description	Symbols	Description
FMI	Indoor Fan Motor	TH3	Thermistor (Indoor Coil E2)
49FI	Indoor Motor Thermal Protector	TH4	Thermistor (Indoor Coil E3)
RC1	Running Capacitor	CR-X253GH	Indoor Controller
F1	Fuse	⊕	Terminal Plate
LM	Auto Louver Motor	□	Connector
TR1	Power Transformer	⊕	Terminal
1X-3X	Auxiliary Relay	DP	Drain Pump
RY1-RY2	Auxiliary Relay	DPH	Dew Proof Heater
MOV	Motor Operated Valve	LSW	Limit Switch
RCS	Remote Control Switch	FS	Float Switch
TH1	Room Thermistor		
TH2	Thermistor (Indoor Coil E1)		

© 854-2-5268-413-00-2 (S)

2. Indoor Unit

(3) SPW-ASR93GH56, SPW-ASR123GH56

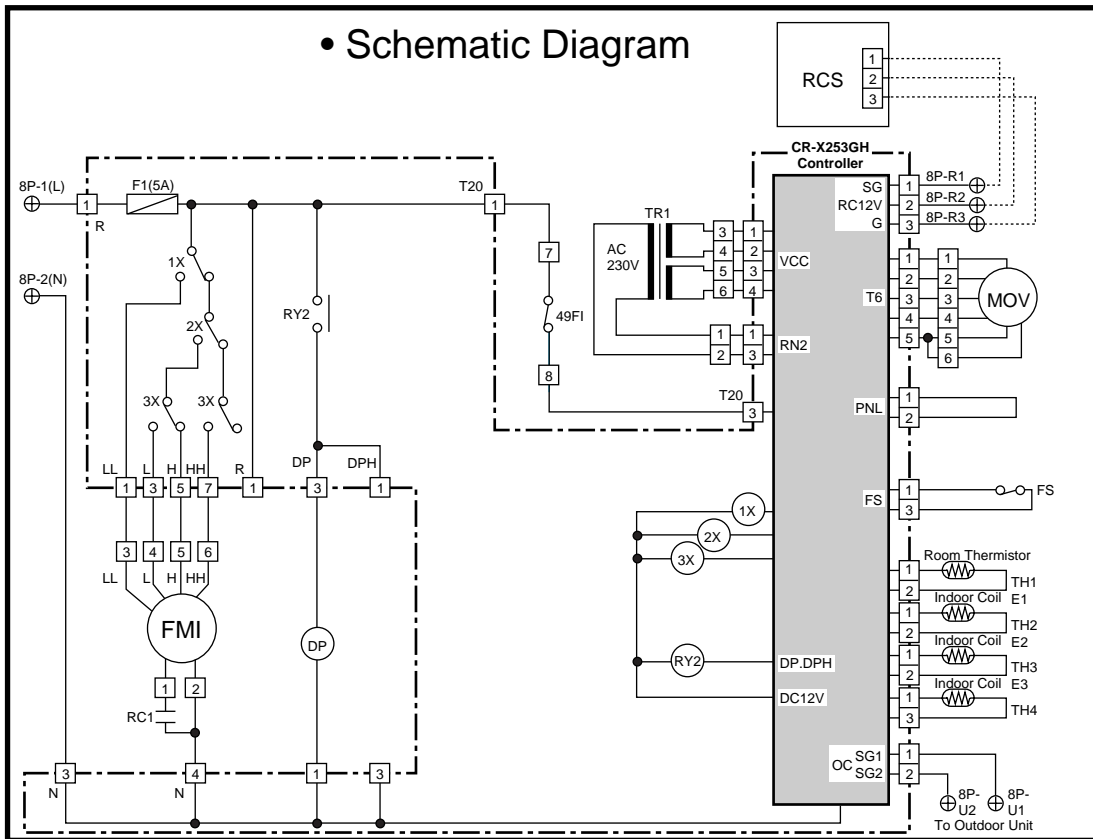

Symbols	Description	Symbols	Description
FMI	Indoor Fan Motor	TH3	Thermistor (Indoor Coil E2)
49FI	Indoor Motor Thermal Protector	TH4	Thermistor (Indoor Coil E3)
RC1	Running Capacitor	CR-X253GH	Indoor Controller
F1	Fuse	⊕	Terminal Plate
DP	Drain Pump	□	Connector
TR1	Power Transformer	Ⓢ	Terminal
1X-3X	Auxiliary Relay	FS	Float Switch
RY2	Auxiliary Relay		
MOV	Motor Operated Valve		
RCS	Remote Control Switch		
TH1	Room Thermistor		
TH2	Thermistor (Indoor Coil E1)		

© 854-2-5268-411-00-2 (AS)

2. Indoor Unit

(4) SPW-KR93GH56, SPW-KR123GH56, SPW-KR183GH56

• Electric Wiring Diagram

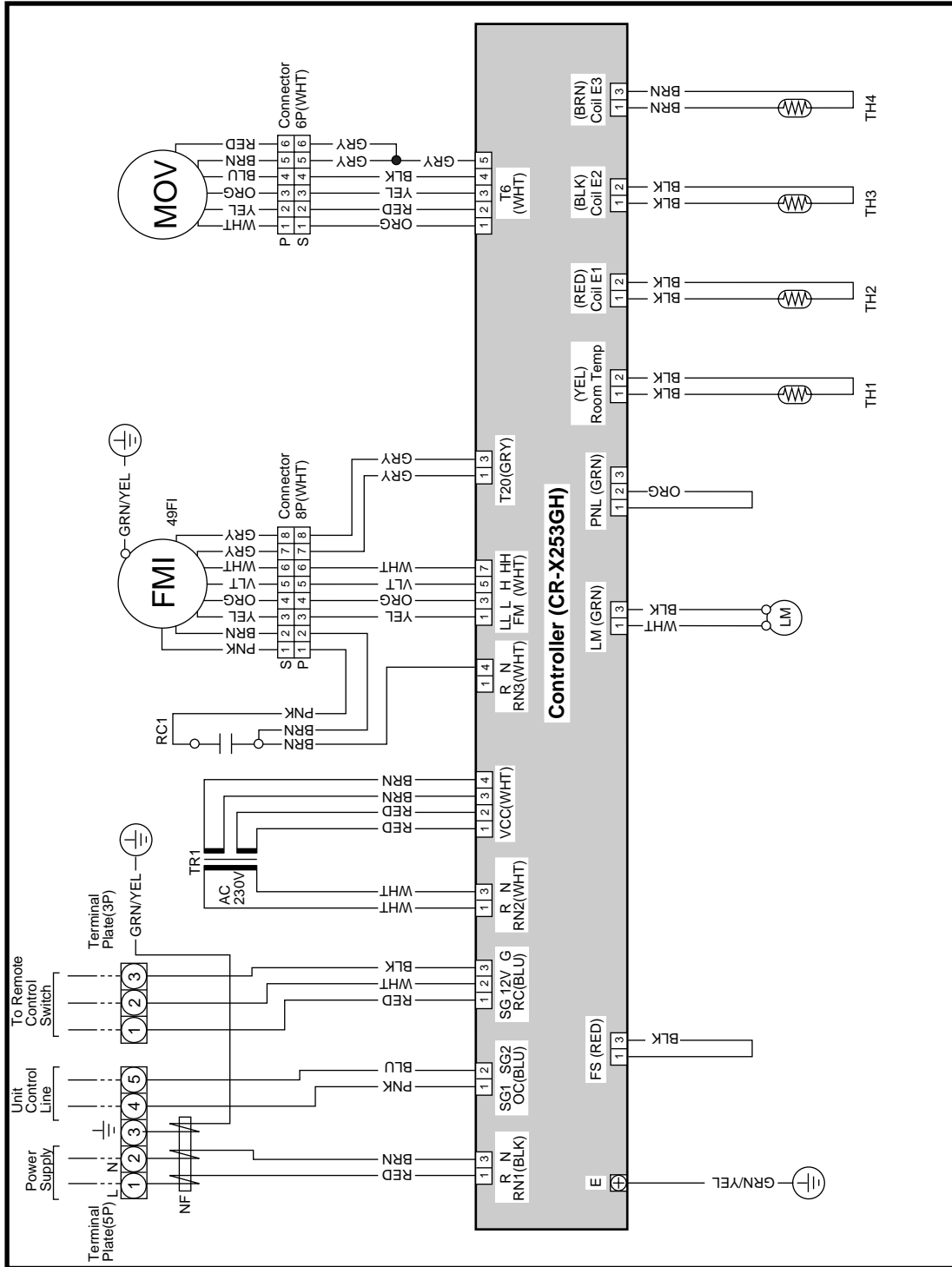

Ⓜ 854-2-5268-410-00-3 (K)

2. Indoor Unit

(4) SPW-KR93GH56, SPW-KR123GH56, SPW-KR183GH56

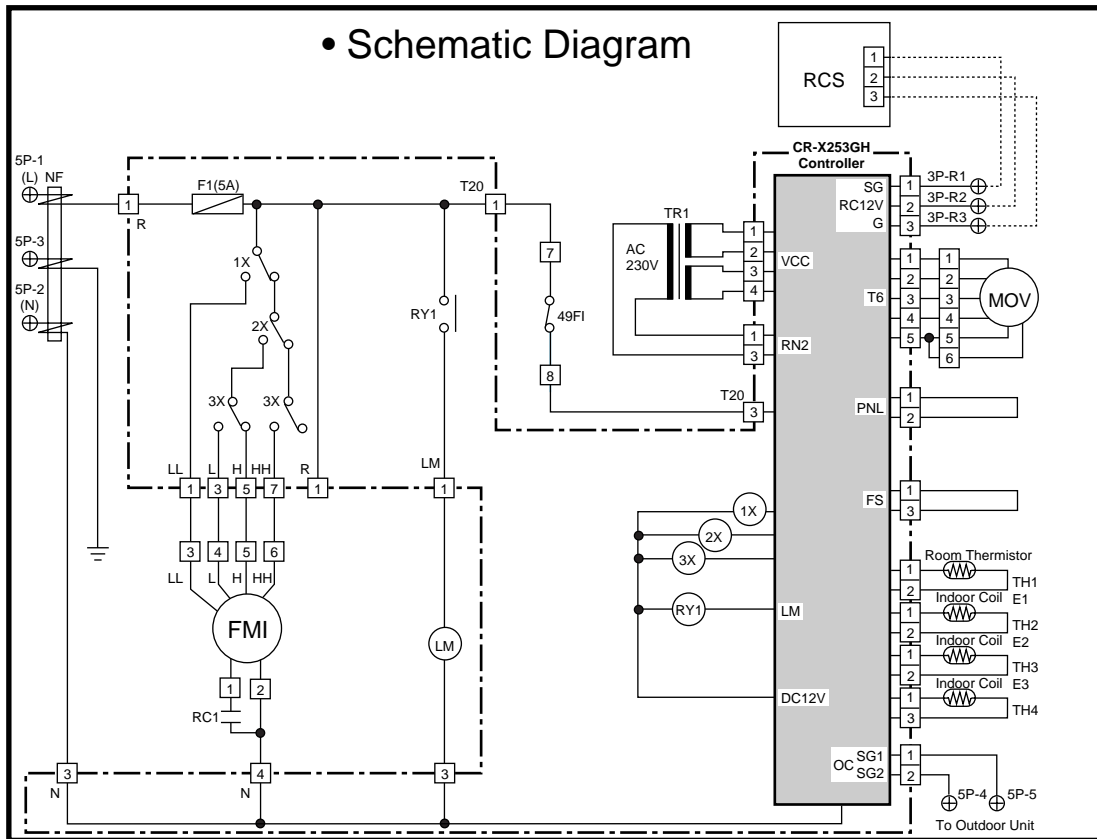

Symbols	Description	Symbols	Description
FMI	Indoor Fan Motor	TH3	Thermistor (Indoor Coil E2)
49FI	Indoor Motor Thermal Protector	TH4	Thermistor (Indoor Coil E3)
RC1	Running Capacitor	CR-X253GH	Indoor Controller
F1	Fuse	⊕	Terminal Plate
LM	Auto Louver Motor	□	Connector
TR1	Power Transformer	⊕	Terminal
1X-3X	Auxiliary Relay	NF	Noise Filter
RY1	Auxiliary Relay		
MOV	Motor Operated Valve		
RCS	Remote Control Switch		
TH1	Room Thermistor		
TH2	Thermistor (Indoor Coil E1)		

© 854-2-5268-410-00-3 (K)

2. Indoor Unit

(5) SPW-TR183GH56, SPW-TR253GH56, SPW-TR363GH56, SPW-TR483GH56

• Electric Wiring Diagram

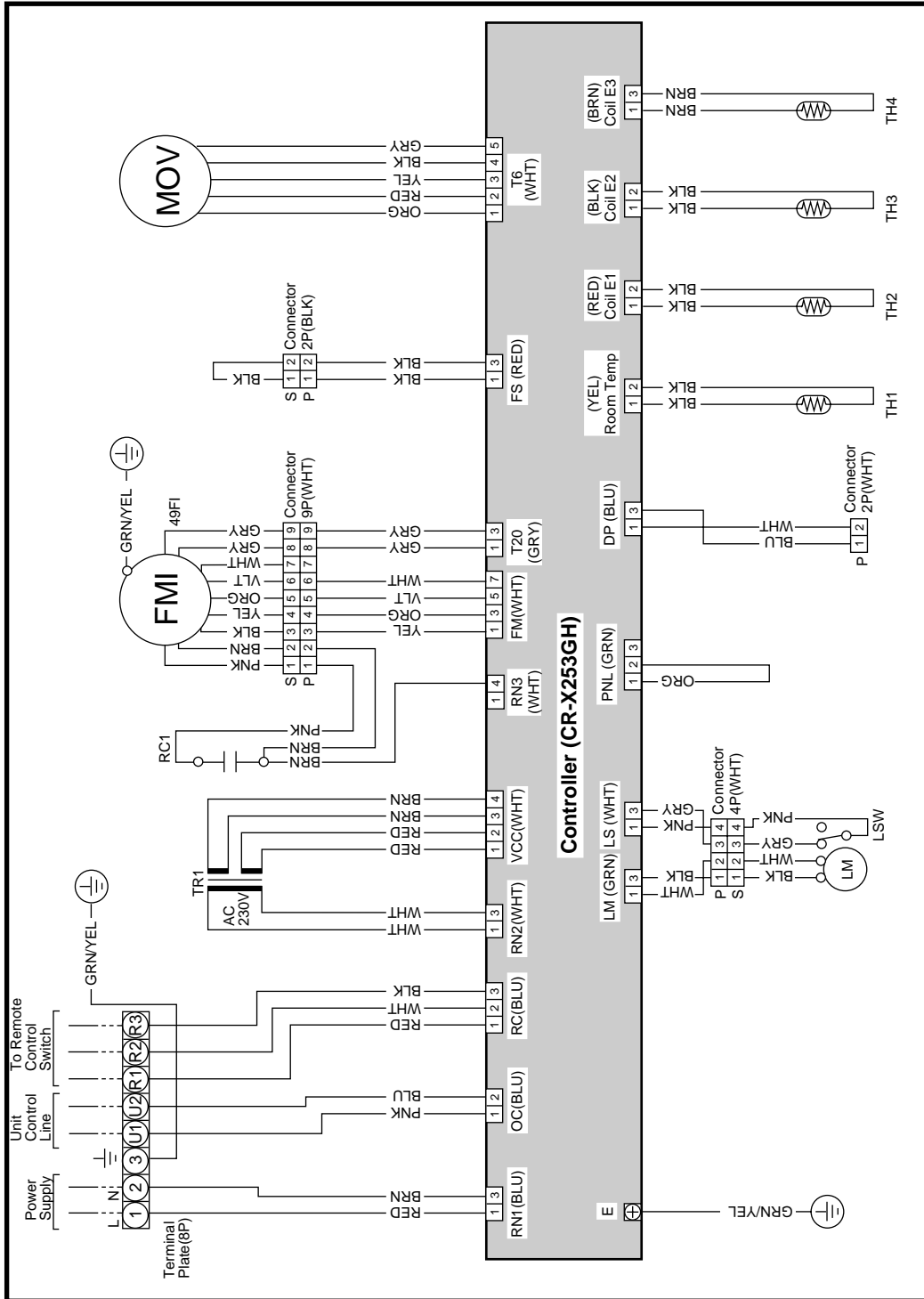

W 854-2-5268-665-00-0 (TR)

2. Indoor Unit

(5) SPW-TR183GH56, SPW-TR253GH56, SPW-TR363GH56, SPW-TR483GH56

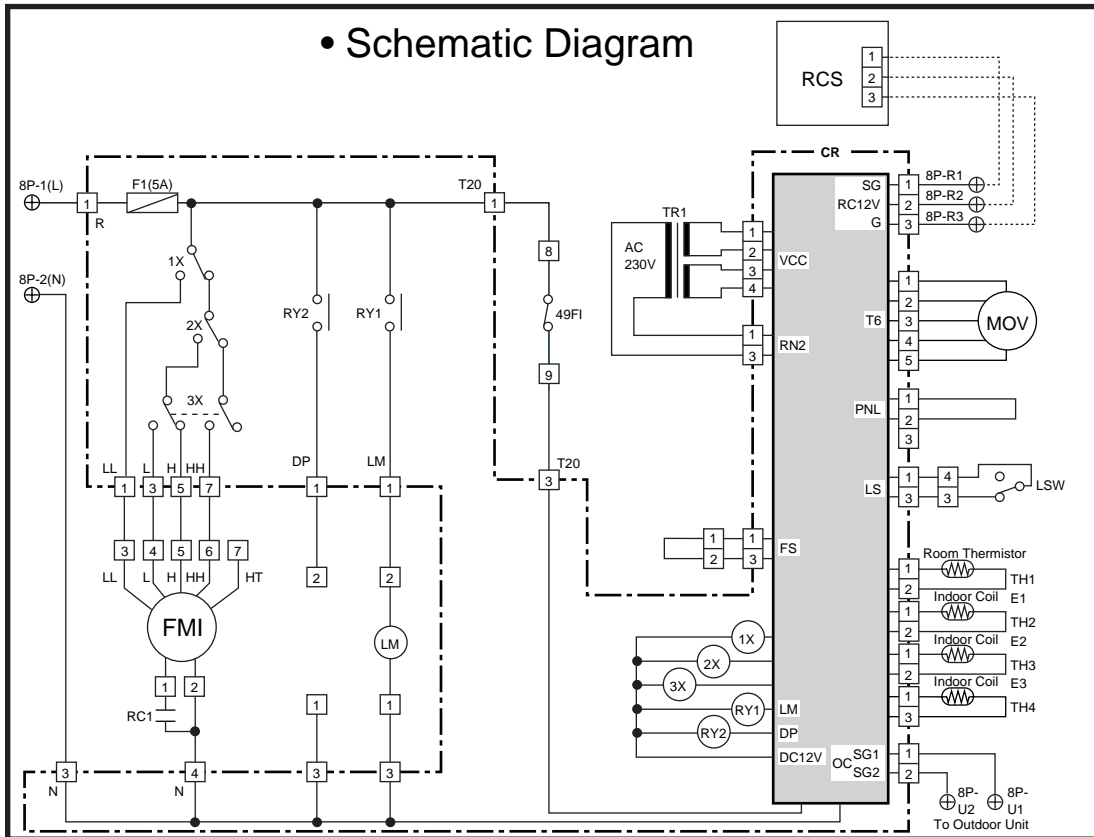

Symbols	Description	Symbols	Description
FMI	Indoor Fan Motor	TH4	Thermistor (Indoor Coil E3)
MOV	Motor Operated Valve	F1	Fuse
49FI	Indoor Motor Thermal Protector	1X-3X	Auxiliary Relay
RC1	Running Capacitor	RY1-RY2	Auxiliary Relay
TR1	Power Transformer	CR	Indoor Controller
LM	Auto Louver Motor	RCS	Remote Control Switch
LSW	Limit Switch	⊕	Terminal Plate
TH1	Room Thermistor	□	Connector
TH2	Thermistor (Indoor Coil E1)	⊕	Terminal
TH3	Thermistor (Indoor Coil E2)		

© 854-2-5268-665-00-0 (TR)

2. Indoor Unit

(6)-1 SPW-UR93GH56, SPW-UR123GH56, SPW-UR183GH56, SPW-UR253GH56

• Electric Wiring Diagram

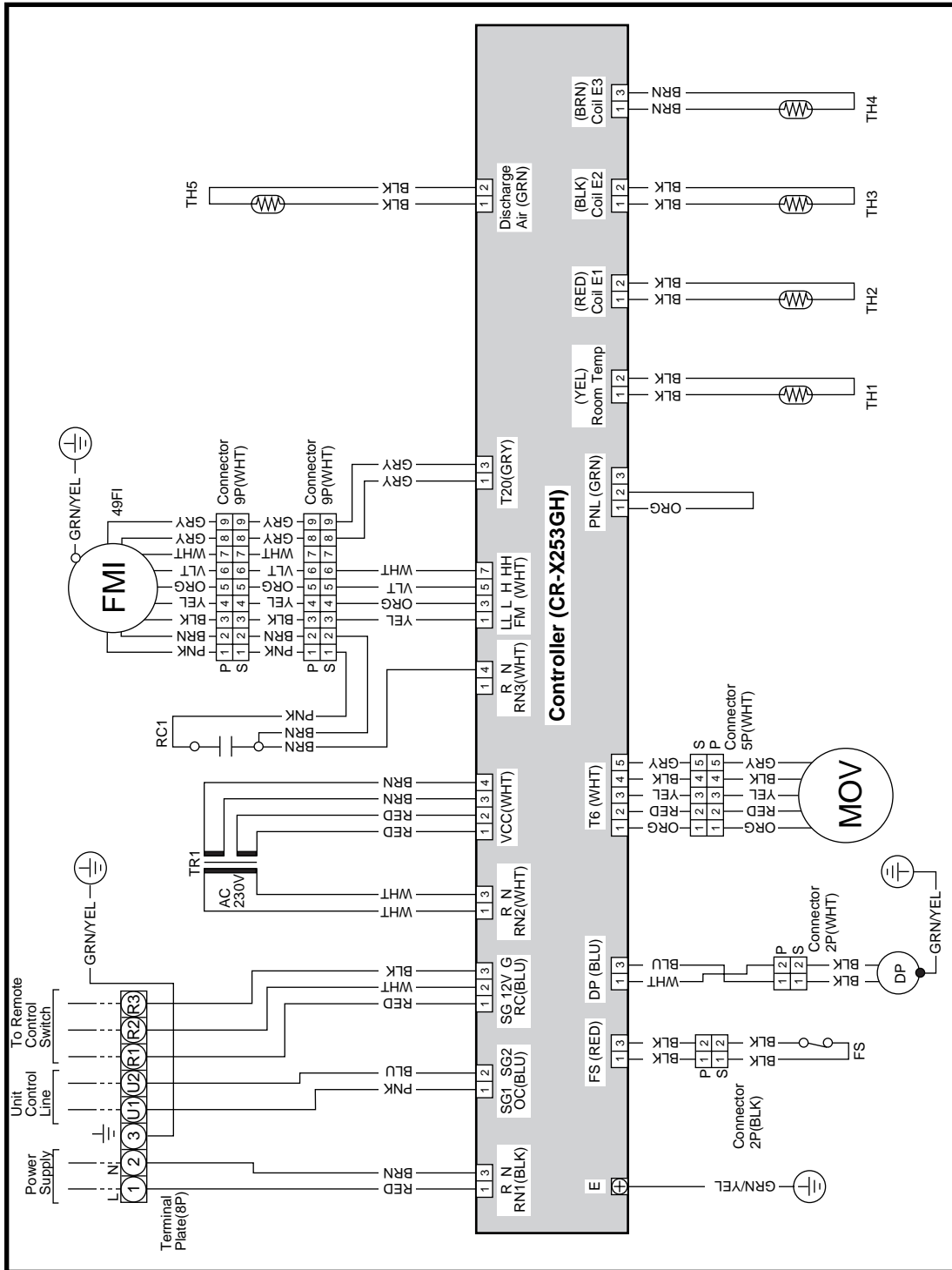

① 854-2-5268-641-00-0 (UR)

2. Indoor Unit

(6)-1 SPW-UR93GH56, SPW-UR123GH56, SPW-UR183GH56, SPW-UR253GH56

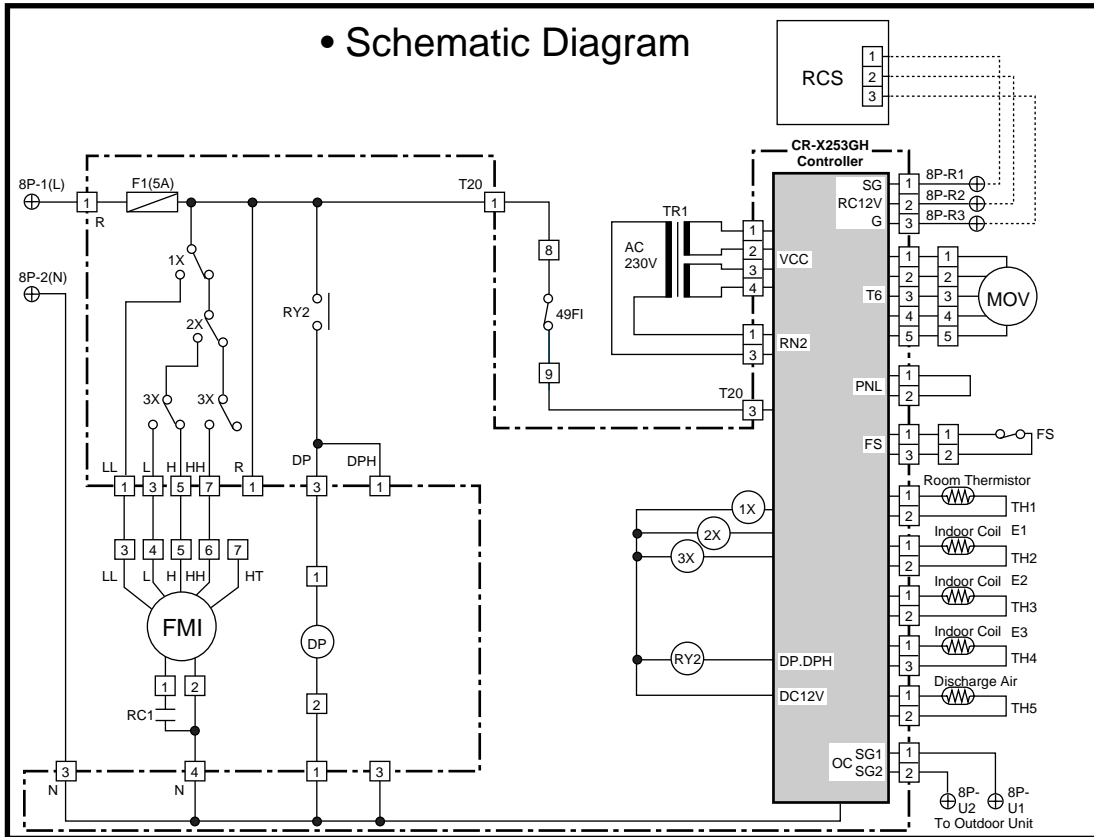

Symbols	Description	Symbols	Description
FMI	Indoor Fan Motor	TH4	Thermistor (Indoor Coil E3)
49FI	Indoor Motor Thermal Protector	TH5	Thermistor (Discharge Air)
RC1	Running Capacitor	CR-X253GH	Indoor Controller
F1	Fuse	⊕	Terminal Plate
TR1	Power Transformer	□	Connector
1X-3X	Auxiliary Relay	⊕	Terminal
RY2	Auxiliary Relay	DP	Drain Pump
MOV	Motor Operated Valve	FS	Float Switch
RCS	Remote Control Switch		
TH1	Room Thermistor		
TH2	Thermistor (Indoor Coil E1)		
TH3	Thermistor (Indoor Coil E2)		

© 854-2-5268-641-00-0 (UR)

2. Indoor Unit

(6)-2 SPW-UR363GH56, SPW-UR483GH56

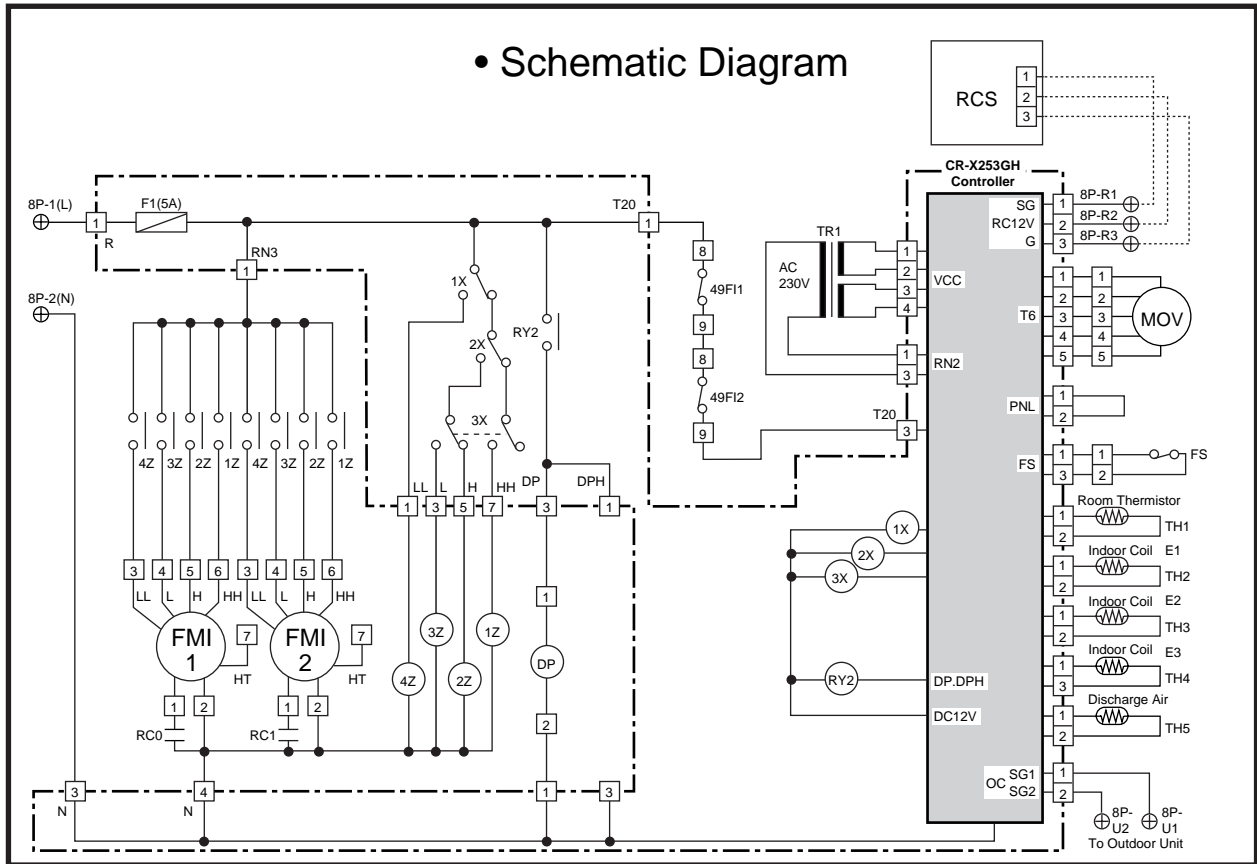

Symbols	Description	Symbols	Description
FMI1, 2	Indoor Fan Motor	TH4	Thermistor (Indoor Coil E3)
49FI1, 2	Indoor Motor Thermal Protector	TH5	Thermistor (Discharge Air)
RC0, 1	Running Capacitor	CR-X253GH	Indoor Controller
F1	Fuse	⊕	Terminal Plate
TR1	Power Transformer	□	Connector
1X-3X	Auxiliary Relay	⊕	Terminal
RY2	Auxiliary Relay	DP	Drain Pump
MOV	Motor Operated Valve	FS	Float Switch
RCS	Remote Control Switch	1Z-4Z	Auxiliary Relay
TH1	Room Thermistor		
TH2	Thermistor (Indoor Coil E1)		
TH3	Thermistor (Indoor Coil E2)		

© 854-2-5268-642-00-0 (UR)



2. Indoor Unit

(7)-2 SPW-DR363GH56

• Electric Wiring Diagram

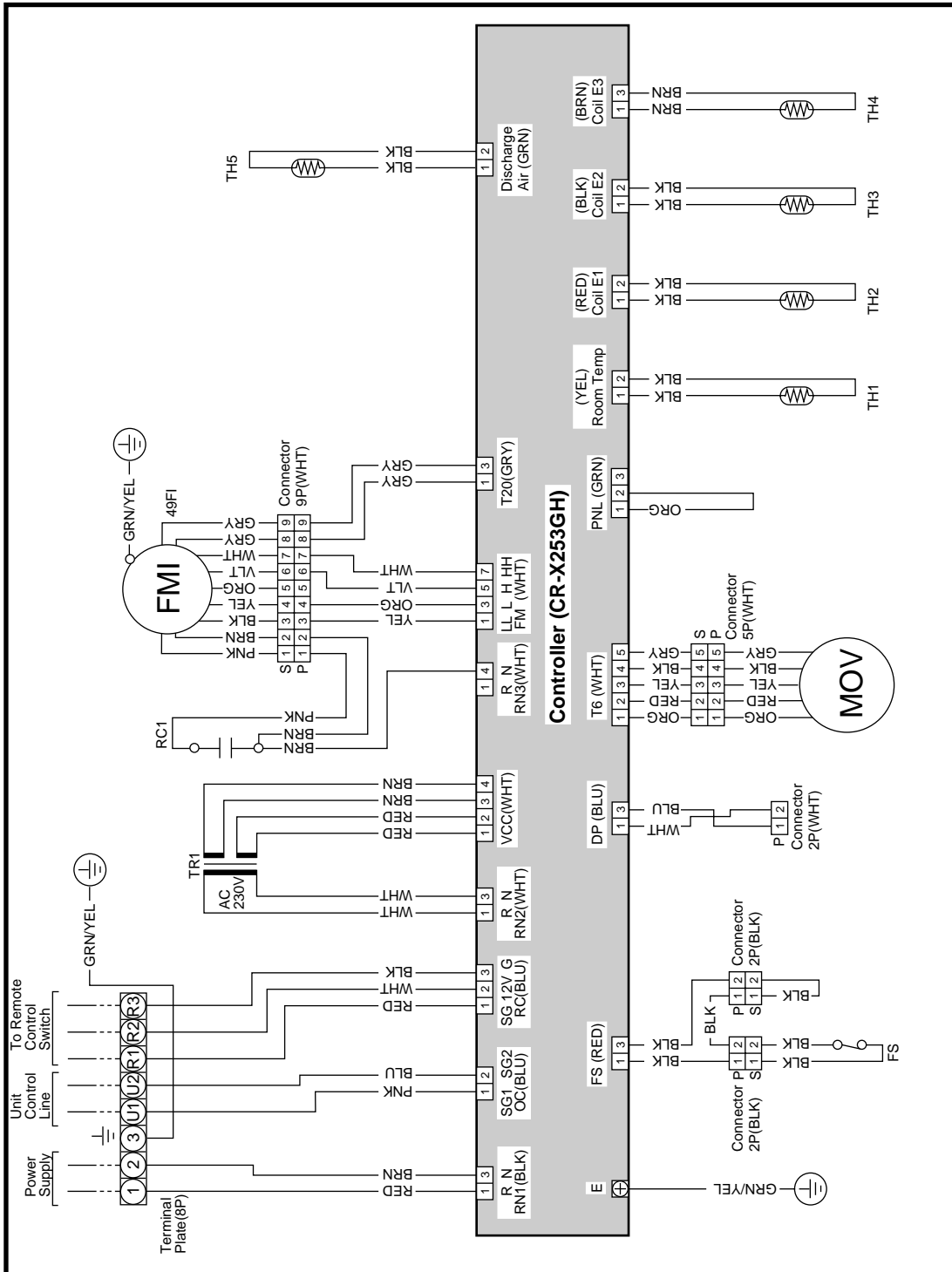

© 854-2-5268-694-00-0 (DR)

2. Indoor Unit

(7)-2 SPW-DR363GH56

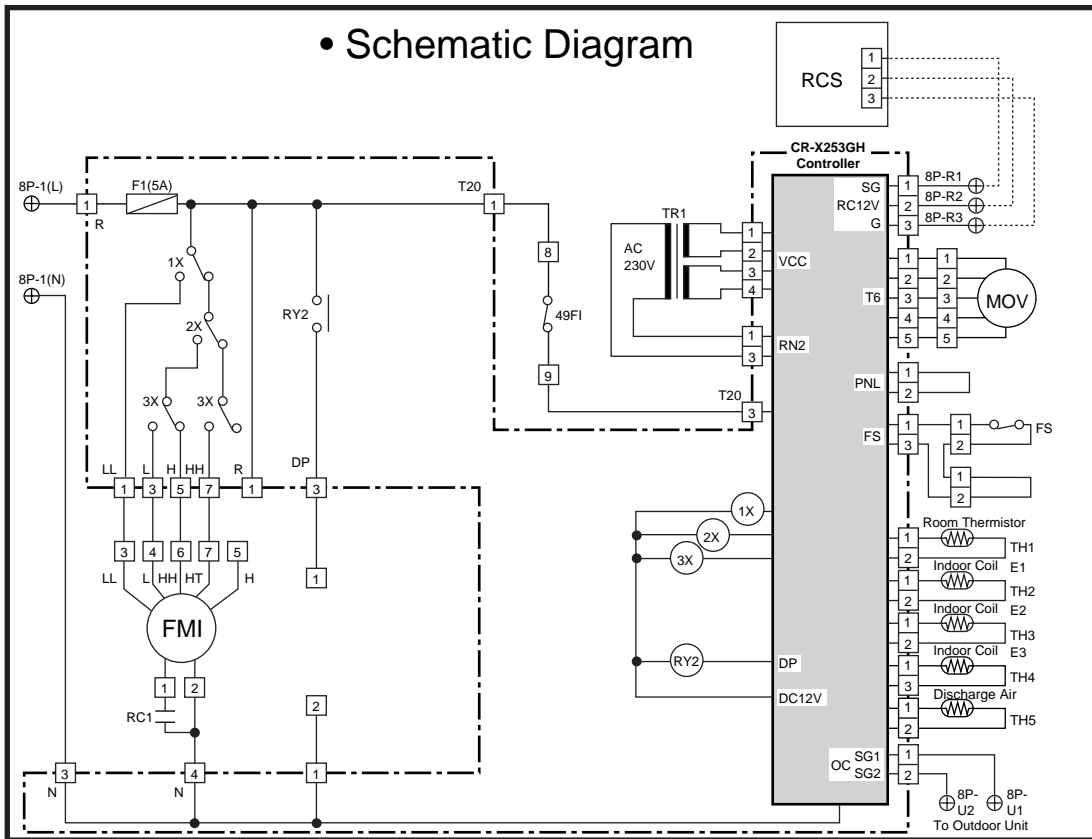

Symbols	Description	Symbols	Description
FMI	Indoor Fan Motor	TH4	Thermistor (Indoor Coil E3)
49FI	Indoor Motor Thermal Protector	TH5	Thermistor (Discharge Air)
RC1	Running Capacitor	CR-X253GH	Indoor Controller
F1	Fuse	⊕	Terminal Plate
TR1	Power Transformer	□	Connector
1X-3X	Auxiliary Relay	⊕	Terminal
RY2	Auxiliary Relay	FS	Float Switch
MOV	Motor Operated Valve		
RCS	Remote Control Switch		
TH1	Room Thermistor		
TH2	Thermistor (Indoor Coil E1)		
TH3	Thermistor (Indoor Coil E2)		

© 854-2-5268-694-00-0 (DR)

2. Indoor Unit

(7)-3 SPW-DR483GH56

4

• Electric Wiring Diagram

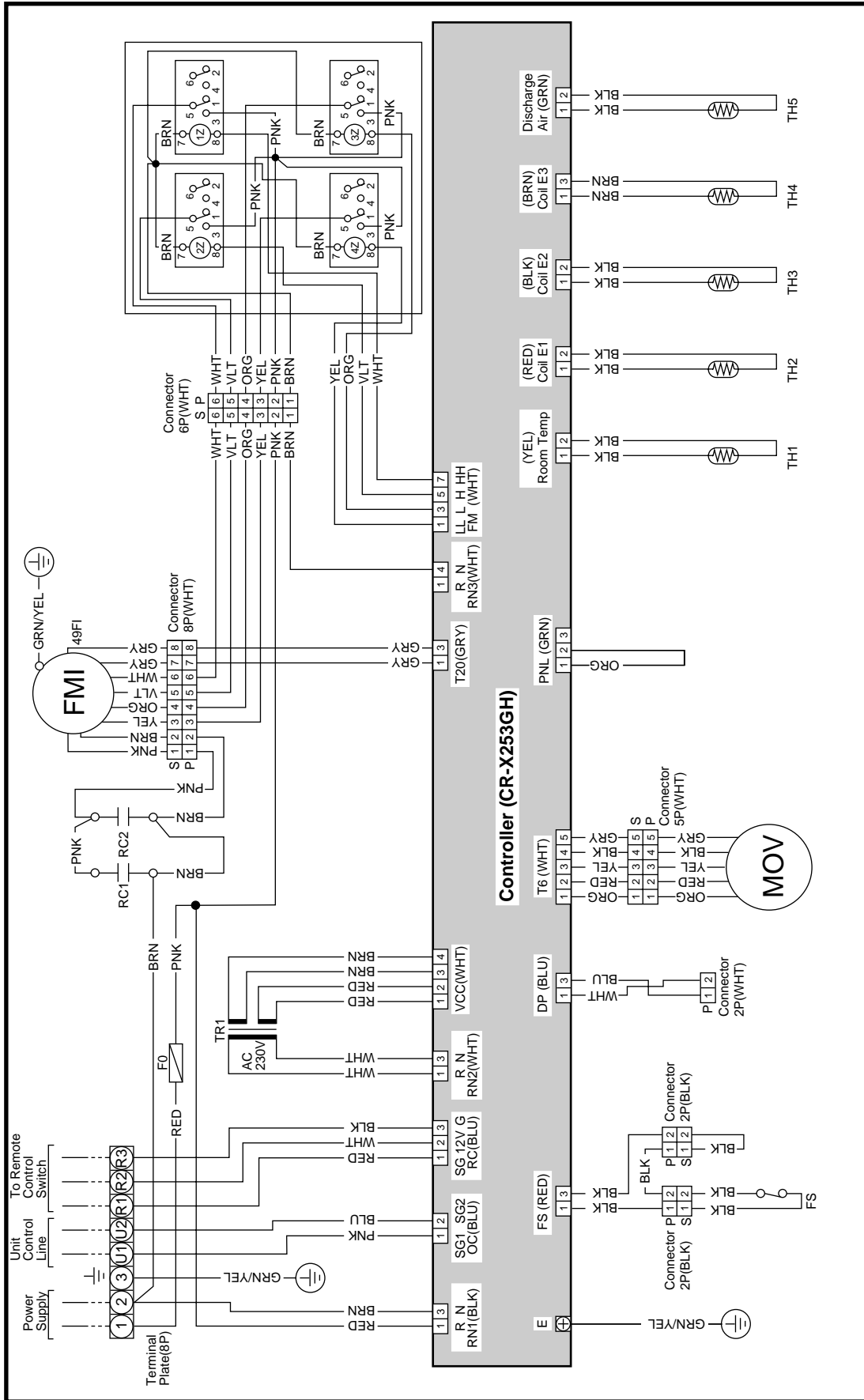

© 854-2-5268-695-00-0 (DR)

2. Indoor Unit

(7)-3 SPW-DR483GH56

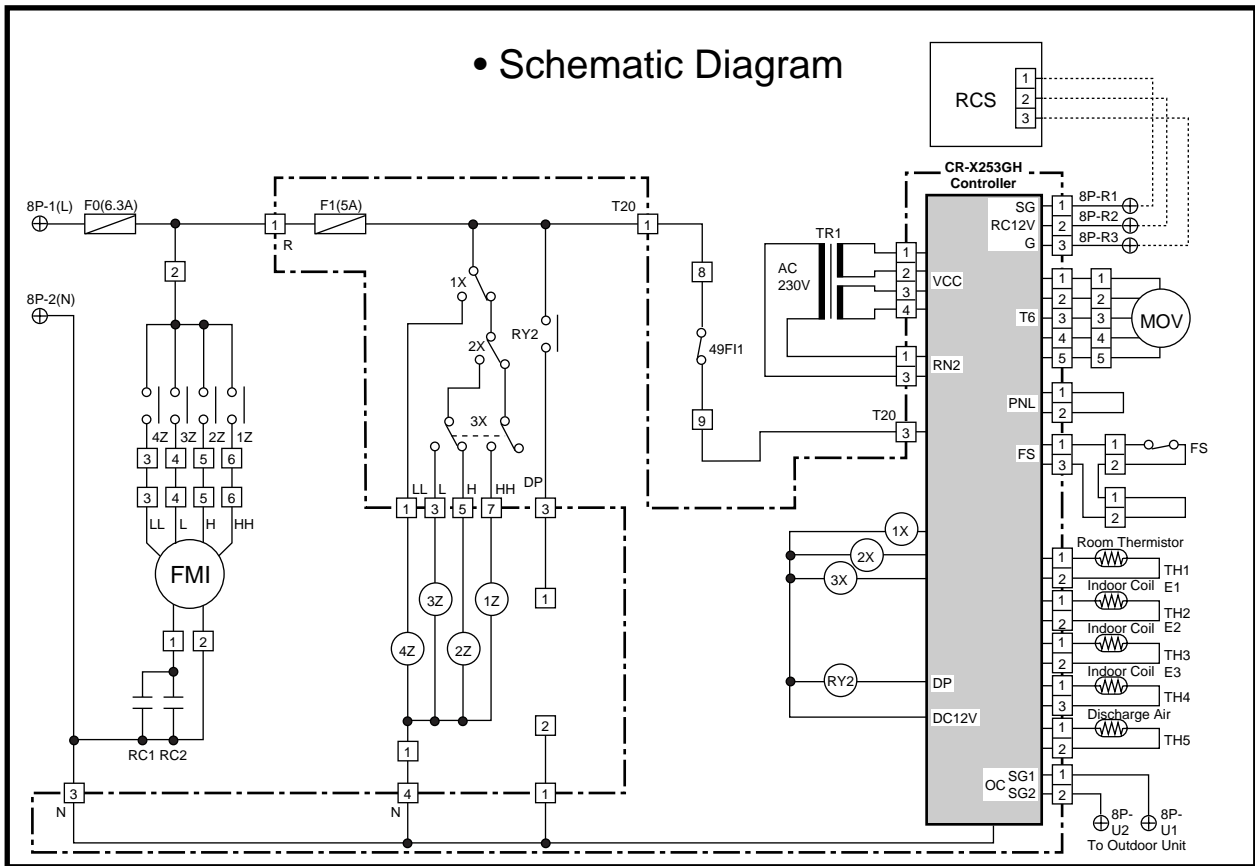

Symbols	Description	Symbols	Description
FMI	Indoor Fan Motor	TH4	Thermistor (Indoor Coil E3)
49FI	Indoor Motor Thermal Protector	TH5	Thermistor (Discharge Air)
RC1, 2	Running Capacitor	CR-X253GH	Indoor Controller
F0, 1	Fuse	⊕	Terminal Plate
TR1	Power Transformer	□	Connector
1X-3X	Auxiliary Relay	⊕	Terminal
RY2	Auxiliary Relay	FS	Float Switch
MOV	Motor Operated Valve	1Z-4Z	Auxiliary Relay
RCS	Remote Control Switch		
TH1	Room Thermistor		
TH2	Thermistor (Indoor Coil E1)		
TH3	Thermistor (Indoor Coil E2)		

© 854-2-5268-695-00-0 (DR)

2. Indoor Unit

(8) SPW-FR93GH56, SPW-FR123GH56, SPW-FR183GH56, SPW-FR253GH56

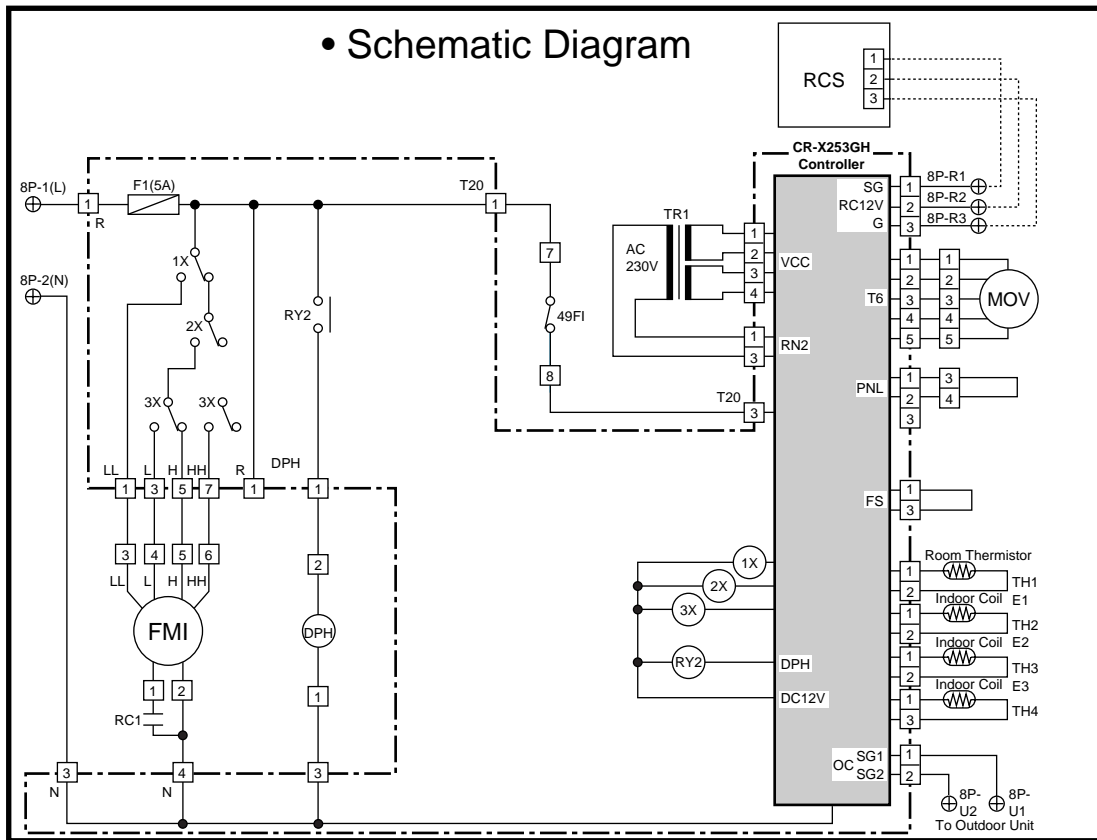

Symbols	Description
FMI	Indoor Fan Motor
49FI	Indoor Motor Thermal Protector
RC1	Running Capacitor
F1	Fuse
TR1	Power Transformer
1X-3X	Auxiliary Relay
RY2	Auxiliary Relay
MOV	Motor Operated Valve
RCS	Remote Control Switch
TH1	Room Thermistor
TH2	Thermistor (Indoor Coil E1)
TH3	Thermistor (Indoor Coil E2)
TH4	Thermistor (Indoor Coil E3)
CR-X253GH	Indoor Controller
⊕	Terminal Plate
□	Connector
⊕	Terminal
DPH	Dew Proof Heater

© 854-2-5268-558-00-0 (FR93GH56, FR123GH56, FR183GH56, FR253GH56)

2. Indoor Unit

(9) SPW-FMR93GH56, SPW-FMR123GH56, SPW-FMR183GH56, SPW-FMR253GH56

• Electric Wiring Diagram

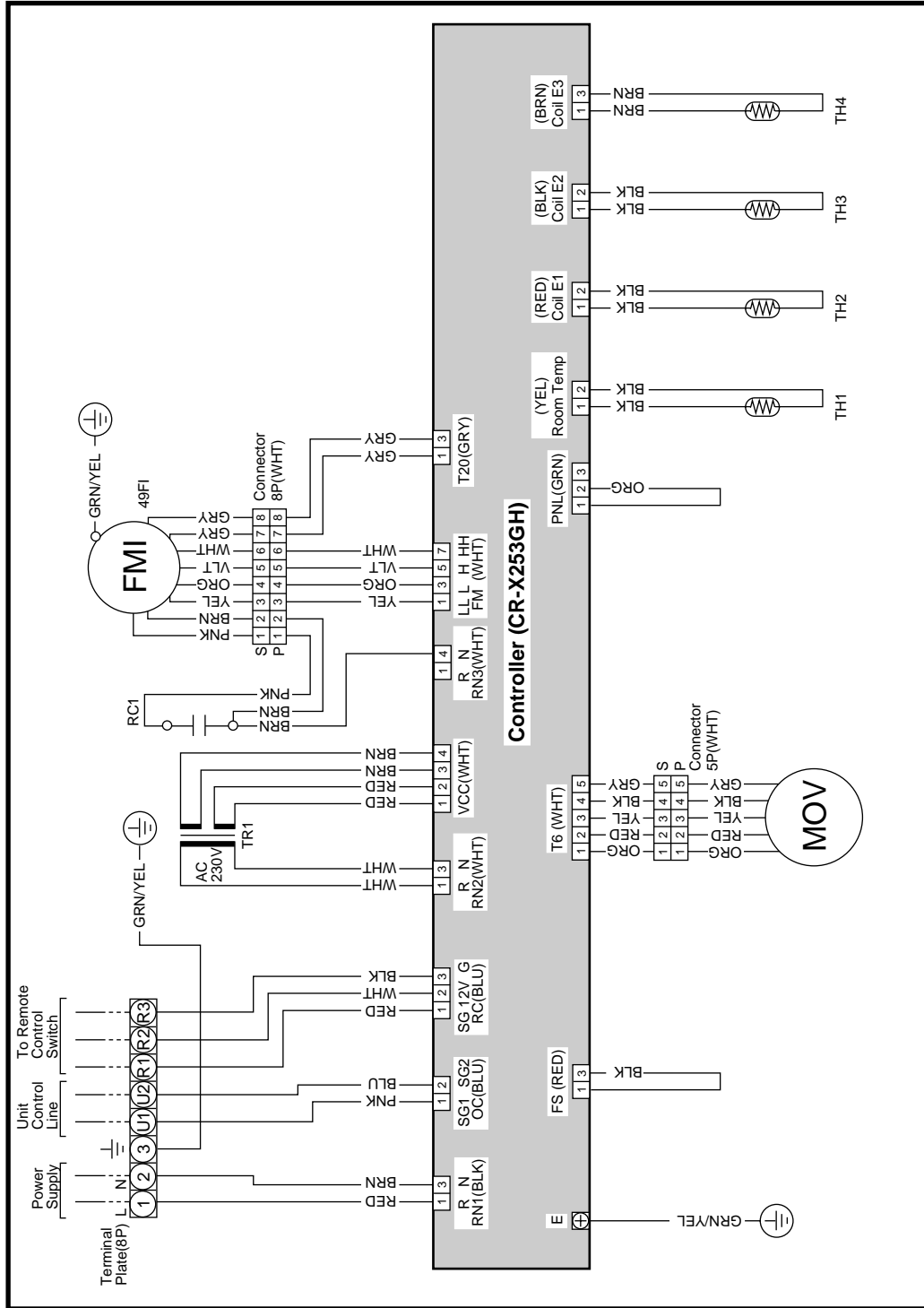

© 854-2-5268-559-00-0 (FMR93GH56, FMR123GH56, FMR183GH56, FMR253GH56)

2. Indoor Unit

(9) SPW-FMR93GH56, SPW-FMR123GH56, SPW-FMR183GH56, SPW-FMR253GH56

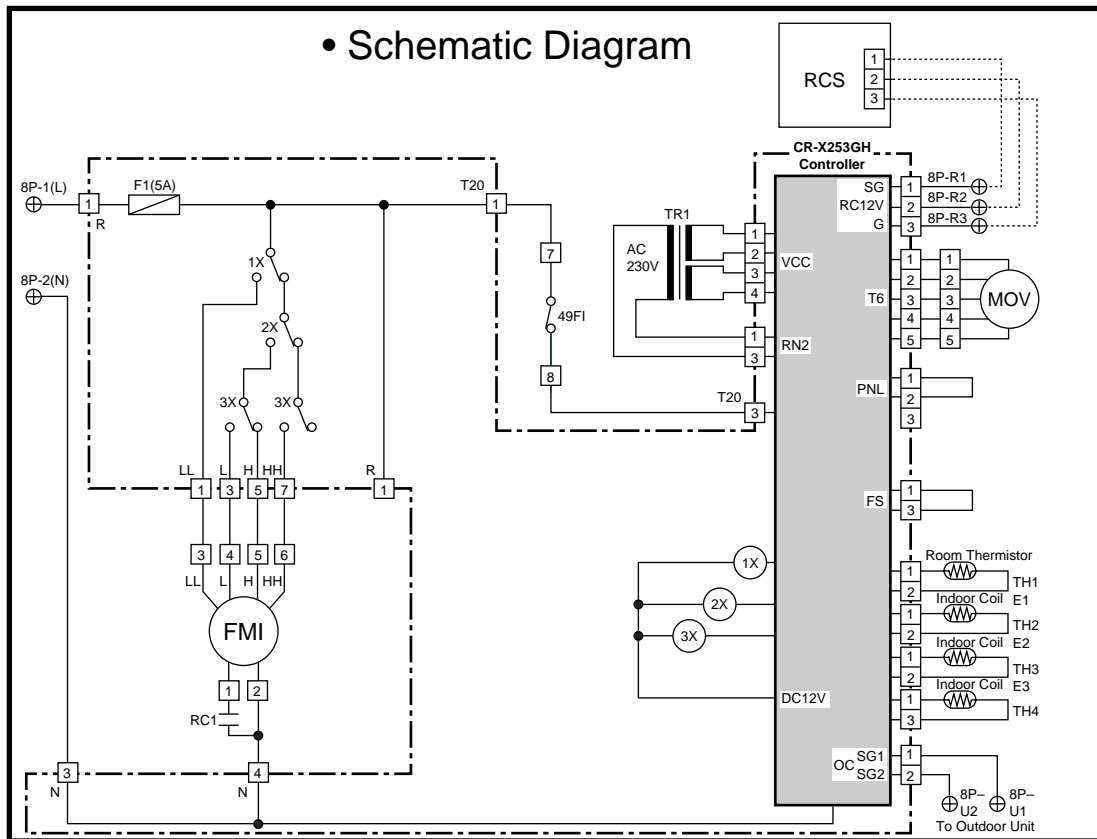

Symbols	Description
FMI	Indoor Fan Motor
49FI	Indoor Motor Thermal Protector
RC1	Running Capacitor
F1	Fuse
TR1	Power Transformer
1X-3X	Auxiliary Relay
MOV	Motor Operated Valve
RCS	Remote Control Switch
TH1	Room Thermistor
TH2	Thermistor (Indoor Coil E1)
TH3	Thermistor (Indoor Coil E2)
TH4	Thermistor (Indoor Coil E3)
CR-X253GH	Indoor Controller
⊕	Terminal Plate
□	Connector
⊕	Terminal

© 854-2-5268-559-00-0 (FMR93GH56, FMR123GH56, FMR183GH56, FMR253GH56)

2. Indoor Unit

(10) SPW-SLR93GH56, SPW-SLR123GH56, SPW-SLR183GH56, SPW-SLR253GH56

• Electric Wiring Diagram

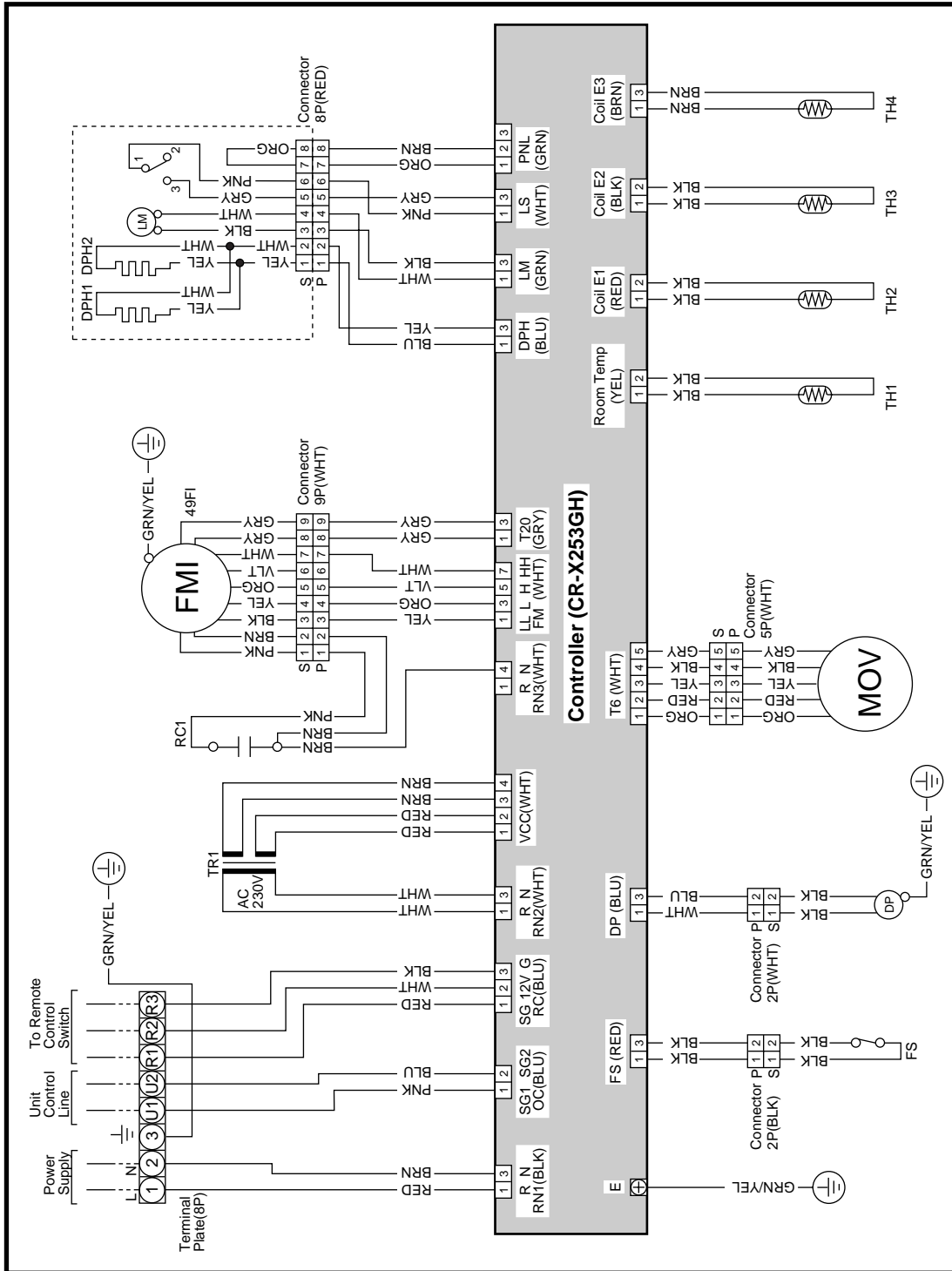

Ⓒ 854-2-5268-710-00-1

2. Indoor Unit

(10) SPW-SLR93GH56, SPW-SLR123GH56, SPW-SLR183GH56, SPW-SLR253GH56

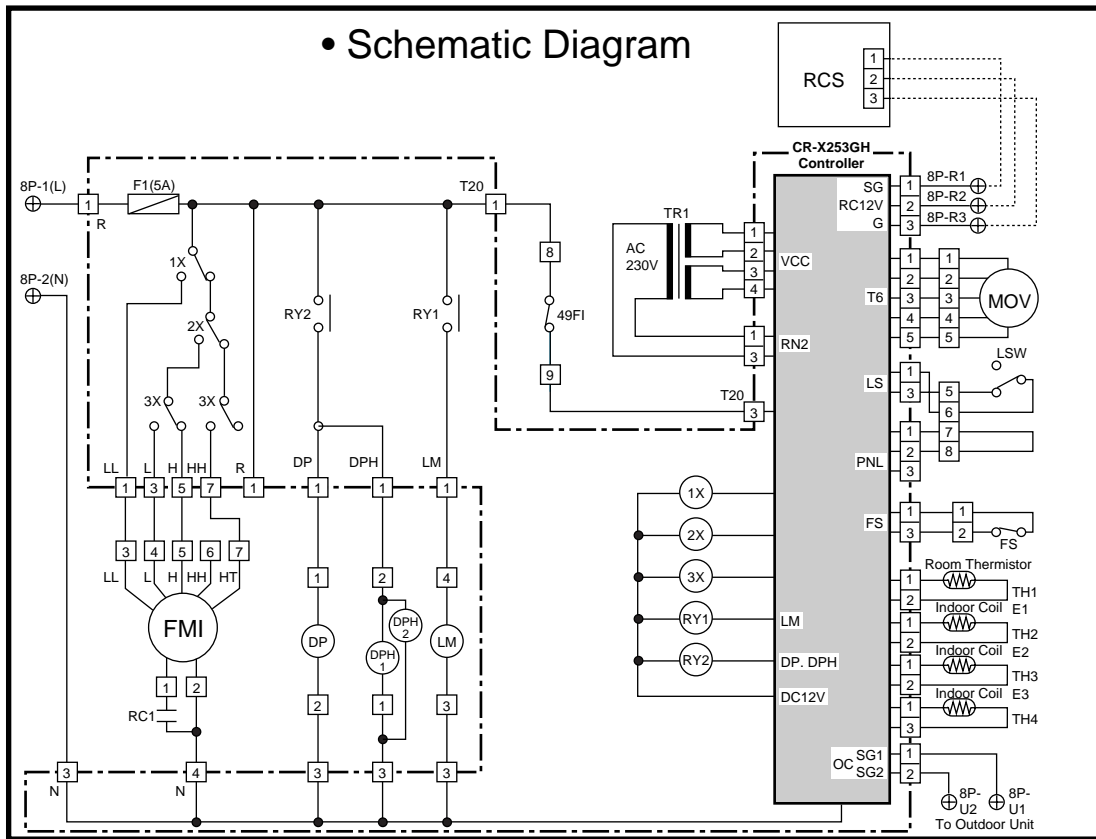

Symbols	Description	Symbols	Description
FMI	Indoor Fan Motor	TH4	Thermistor (Indoor Coil E3)
49FI	Indoor Motor Thermal Protector	CR-X253GH	Indoor Controller
RC1	Running Capacitor	⊕	Terminal Plate
F1	Fuse	□	Connector
TR1	Power Transformer	⊗	Terminal
1X-3X	Auxiliary Relay	DPH1,2	Dew Proof Heater
RY1-RY2	Auxiliary Relay	LSW	Limit Switch
MOV	Motor Operated Valve	FS	Float Switch
RCS	Remote Control Switch	DP	Drain Pump
TH1	Room Thermistor		
TH2	Thermistor (Indoor Coil E1)		
TH3	Thermistor (Indoor Coil E2)		

© 854-2-5268-710-00-1

• The specifications, designs, and information in this brochure are subject to change without notice.



SANYO Electric Co., Ltd.

Osaka, Japan

G1299 © 500 Printed in Japan